

FILTREAU™



Catalogue



The best solution for water pollution

Contact information

Address

Ekkersrijt 7418
5692HK Son
The Netherlands

Contact:

Phone: +31(0)499-462929
Email: info@wimaca.nl

Opening Hours:

Monday to Thursday: 8.30 – 16.30 uur
Friday: 8.30 – 12.00 uur

General Terms and Conditions of Delivery

Our terms and conditions are available for viewing or download on our website.



Why a filter from **FILTREAU**?

- ✓ Sustainable Production
- ✓ Custom-made / Private Label
- ✓ Price-performance Ration
- ✓ Service-driven
- ✓ 100% produced in The Netherlands

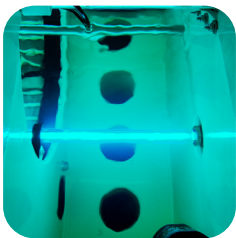

40+ years experience

Low prices, high quality

Our years of experience mean that we know exactly what works and what doesn't. This puts us in an excellent position to market high quality water filtration products. We keep our prices low by developing and producing all products in-house.

Your own brand name

Private label

Bringing our products to market under your own brand name? That's possible at Wimäca. Together we look at your wishes and we can fully shape our products in your own style.

From your own packaging and user manuals to various promotional materials for trade shows and even a website in your look and feel. Wimäca offers countless possibilities to bring your product to market under your own name.

+62 countries

Worldwide shipping

Wimäca International develops and produces all its (Filtreau) products in the Netherlands.

From our base in Son en Breugel, we serve the professional market worldwide.

We supply customers in over 62 countries.

FILTREAU™ Filters



Excellent series

Evolved through expertise

EXCELLENT LINE

Evolved and optimised

Through acquiring knowledge and applying it in practice, a new and unique filter series has emerged. Current technologies have been optimized and evolved. We proudly present our high-quality filter: the Filtreau Excellent series. This series can easily be expanded with an additional 80-Watt UV-C HO unit, allowing for a fully customized setup that contributes to a clear and healthy pond. It promotes the breakdown of ammonia, nitrite, and nitrate. Because the Filtreau Excellent filters are fully developed inhouse, all aspects have been carefully considered.

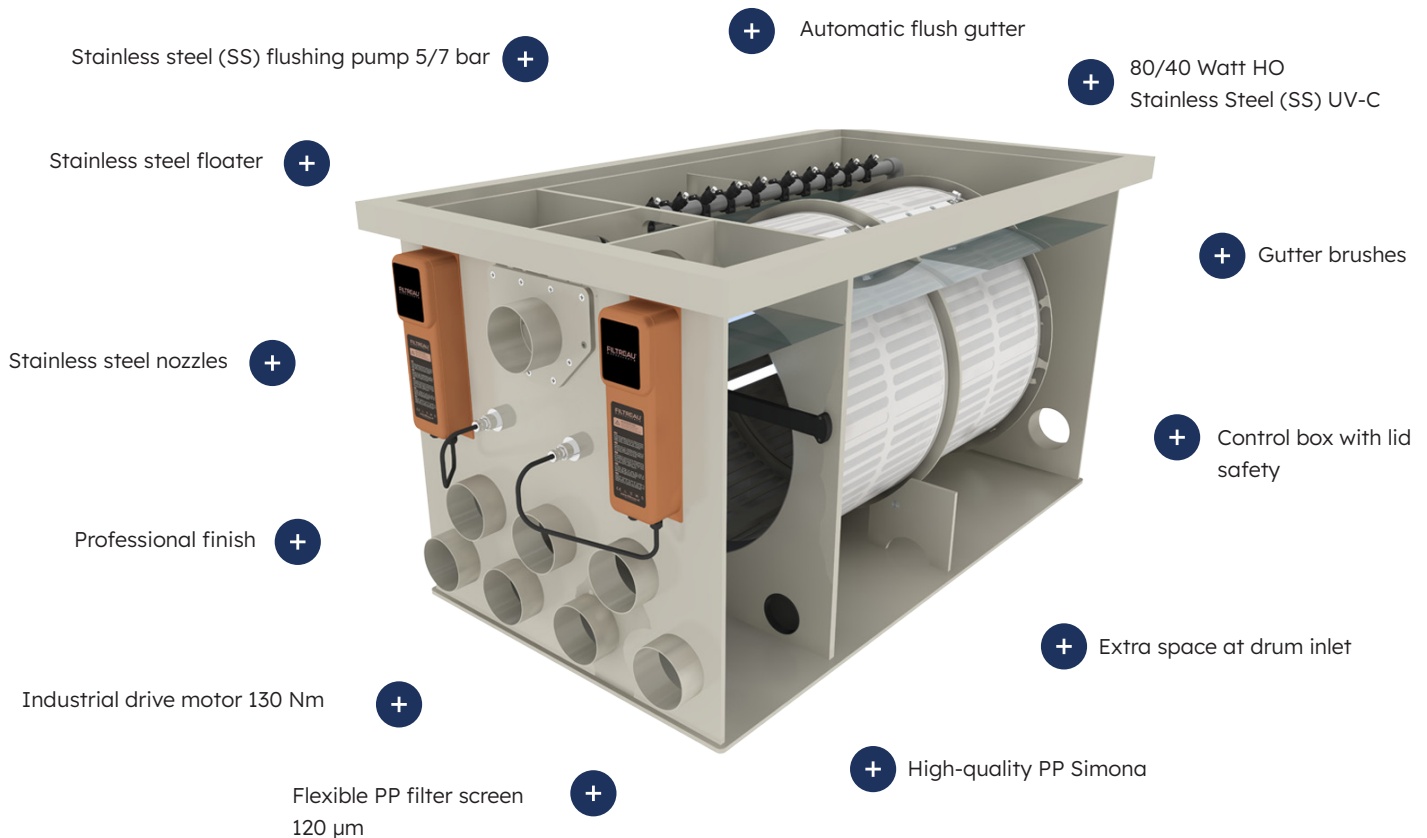

☑ Sustainable production

☑ 40 years experience

☑ Private label / custom solutions

Drum filter

A pre-filter is a drum filter that efficiently removes very fine debris (120 µm) from the water. The water enters the drum filter either pump-fed or gravity-fed, where contaminants are separated from the water. The water flows from the inside of the drum through the filter screen to the outside of the unit. The debris remains on the sieve panel (PP), which is mounted on the drum. The sieve panel (PP) is fitted with a fine stainless steel mesh (120 µm).

The debris is rinsed off the sieve panel (PP) by means of stainless steel nozzles and collected in the gutter. The gutter flushing system ensures that the contaminants are discharged towards the outlet. The cleaning frequency depends on the level of contamination of the pond water.

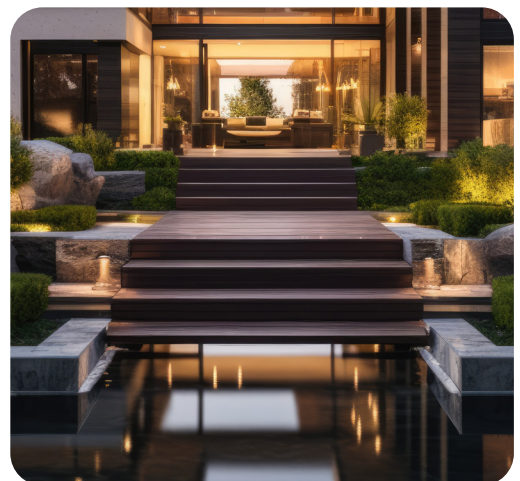

Combi drum filter

Our combi drum filters are equipped with an innovative drum filtration system which, combined with a moving bed filter, ensures optimal water flow and filtration. First, the contaminated pond water enters the collection chamber. The second chamber provides mechanical filtration and houses the drum filter.

In the third chamber, an air disc or air stone is installed at the bottom. This must be connected to an external air pump to create movement within the chamber. For optimal performance, this chamber should be filled to a maximum of 70% of its volume with moving bed media such as Hel-X. After several weeks, beneficial bacteria will attach to the Hel-X, enabling biological filtration of the water. As the media is continuously in motion, no debris can accumulate. This keeps the media clean and results in little to no maintenance.



Combi drum inline filter

The operation of a combi drum inline filter is exactly the same as that of a combi drum filter. The advantage of a combi drum inline filter is that all connections are located on one end of the system. This optimizes the installation of the combi drum inline filter.

Combi drum rotate

The operation of a Combi Drum Rotate is exactly the same as that of a combi drum filter or inline filter. The Combi Drum Rotate features a rotating biological chamber filled with Hel-X, which does not require any additional pump head. Nitrifying bacteria attach to the Hel-X, enabling the breakdown of ammonia and nitrite. In addition, the rotating biological system provides extra oxygenation of the pond.

Trickle filter / Bakki shower

Trickle filters effectively convert harmful dissolved waste substances (nitrite, proteins, ammonium, etc.) in the pond water into harmless compounds. The water first enters the inlet chamber at the top, where it is then evenly distributed over the click grids.

Below this, the elements are placed, also equipped with click grids, allowing the water to flow through easily. The elements can be filled with the desired filter media. This ensures optimal oxygen saturation of the water. Due to the high oxygen levels, the risk of oxygen deficiency in the pond is significantly reduced, even during warmer periods.

The trickle filters are precisely manufactured to seamlessly connect to our combi drum filters. This facilitates the integration of a trickle filter in combination with our combi drum filters.

Private label

For a large number of clients, we manufacture UV-C units and filters under private label. Looking to expand your existing product range with your own branded products? Thanks to our many years of expertise, we understand market demands and can guide you throughout this process.

For more information about private label opportunities, please contact our sales department. Our team will be happy to assist you.

Bio Drum 10 XS

Evolved and optimized

Through the acquisition and practical application of knowledge, a new and unique filter series has been developed. Existing technologies have been further refined and optimized. We proudly present our high-quality filter: the Filtreau Excellent series. This series can be easily expanded with an optional UV-C HO 40/80 watt unit, allowing for a fully configurable system that contributes to a clear and clean pond. It supports the breakdown of ammonia, nitrite and nitrate. As the Filtreau Excellent filters are entirely developed in-house, every aspect has been carefully considered.

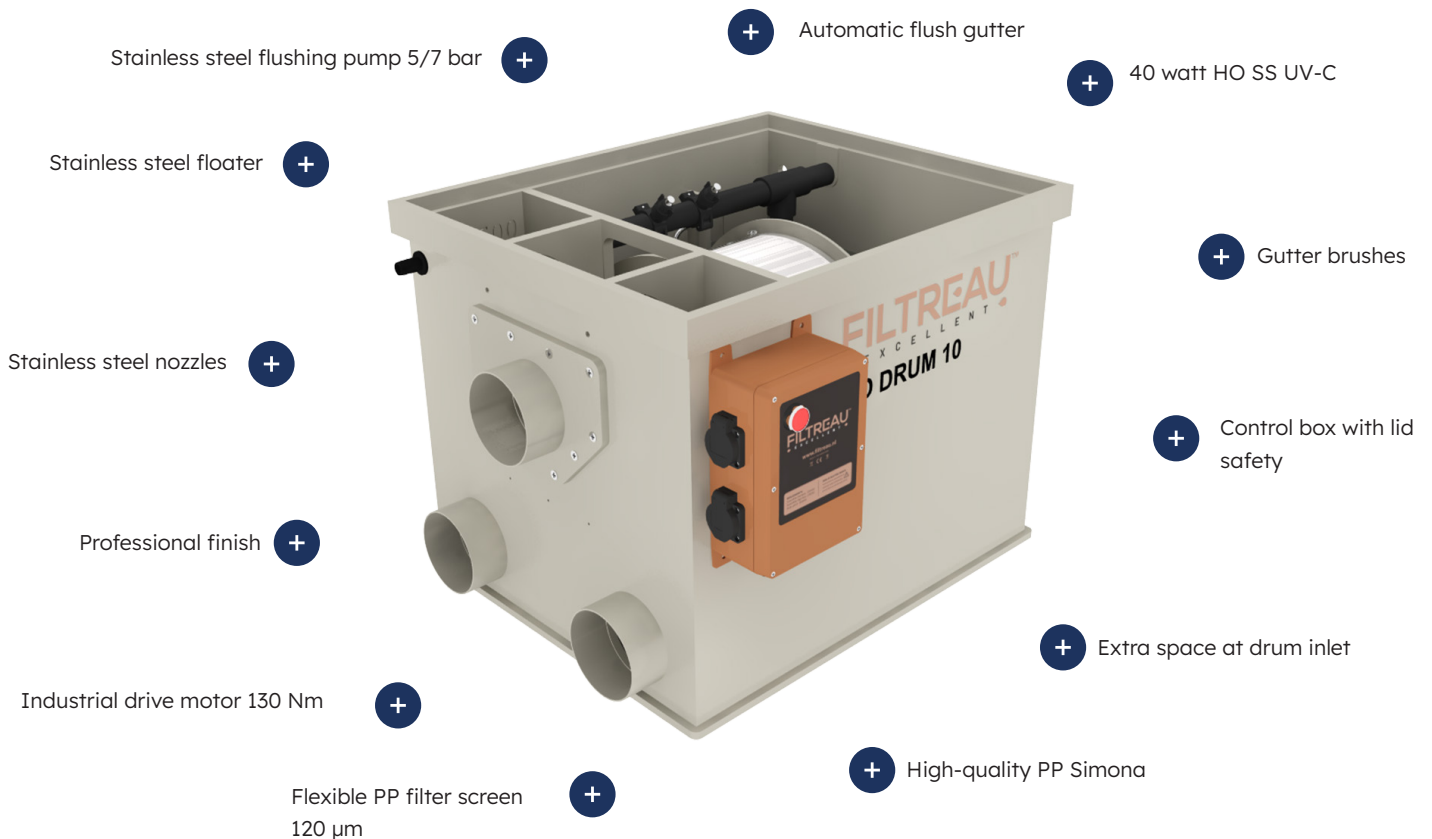

Drum filter

A pre-filter is a drum filter that efficiently removes very fine debris (120 µm) from the water. The water enters the drum filter either pump-fed or gravity-fed, where contaminants are separated from the water. The water flows from the inside of the drum through the filter screen to the outside of the unit. The debris remains on the sieve panel (PP), which is mounted on the drum. The sieve panel (PP) is fitted with a fine stainless steel mesh (120 µm)

The debris is rinsed off the sieve panel (PP) by means of stainless steel nozzles and collected in the gutter. The gutter flushing system ensures that the contaminants are discharged towards the outlet. The cleaning frequency depends on the level of contamination of the pond water.



EXCELLENT LINE

The control box of the Excellent series is standard equipped with:

Automatic cleaning: floor switch. **Manual operation:** turn button / rinse. **Drum flushing time:** 10 sec. **Flushing level (gravity-fed):** adjustable. **Flushing level (pump-fed):** not adjustable. **Power outlets:** flushing pump, pond pump, drum drive motor and UVC HO 40 W or 80 W (stainless steel). **Dry-run protection deactivation:** 30 sec (UVC lamp). **Flush protection:** after 5 minutes of continuous flushing, the control box switches off, manual reset required. **Magnetic safety switch:** opening the lid switches off the control box.

Technical specifications

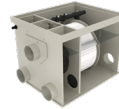

Product	BIO DRUM 10 XS GRAVITY	BIO DRUM 10 XS PUMP
Length x width x height	853 X 530 X 498mm	853 X 530 X 498mm
Drum	Ø 400 x 200mm	Ø 400 x 200mm
Mesh size screen (PP) with stainless steel (SS) mesh	120 µm	120 µm
Max. Flow	10 m ³	7 m ³
Max. pond volume	15 m ³	10 m ³
Max. pond volume with koi	10 m ³	7 m ³
Inlet (mm)	2 x 110mm	2 x 110mm
Outlet (mm)	2 x 110mm	2 x 110mm
Internal flushing pump	SS, 4 bar / 750 W, 220 V	SS, 4 bar / 750 W, 220 V
Industrial motor	130Nm /60 watt 220volt	130Nm /60 watt 220volt
Built-in UVC unit	40 watt H-O	40 watt H-O
Control box	including	including
Item no.	WMC05DRG	WMC05DRP

Spare parts & biological filter media

Product	Item no.
Replacement UV-C HO 40 W lamp for stainless steel (SS) housing	RLM0020
Quartz glass HO 40 W	QS0001
Electrical unit for Inox Excellent 40 watt	EPM0001EX
Sieve panel 1 x 1140 x 200mm Ø 40	ZS00006EX



Discover the complete Excellent series

Bio Drum 15 S

Evolved and optimized

Through the acquisition and practical application of knowledge, a new and unique filter series has been developed. Existing technologies have been further refined and optimized. We proudly present our high-quality filter: the Filtreau Excellent series. This series can be easily expanded with an optional UV-C HO 40/80 watt unit, allowing for a fully configurable system that contributes to a clear and clean pond. It supports the breakdown of ammonia, nitrite and nitrate. As the Filtreau Excellent filters are entirely developed in-house, every aspect has been carefully considered.

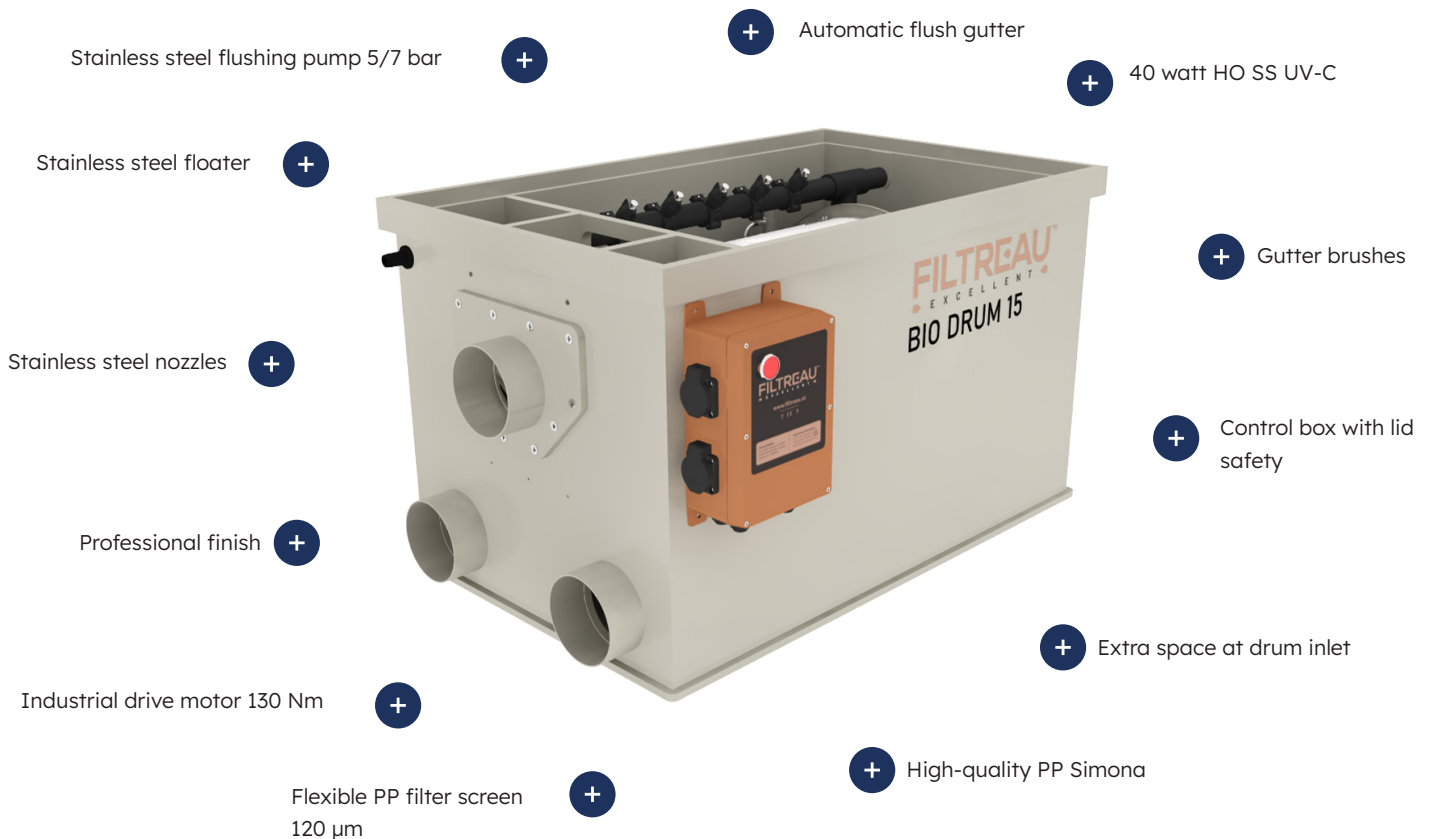

Drum filter

A pre-filter is a drum filter that efficiently removes very fine debris (120 µm) from the water. The water enters the drum filter either pump-fed or gravity-fed, where contaminants are separated from the water. The water flows from the inside of the drum through the filter screen to the outside of the unit. The debris remains on the sieve panel (PP), which is mounted on the drum. The sieve panel (PP) is fitted with a fine stainless steel mesh (120 µm)

The debris is rinsed off the sieve panel (PP) by means of stainless steel nozzles and collected in the gutter. The gutter flushing system ensures that the contaminants are discharged towards the outlet. The cleaning frequency depends on the level of contamination of the pond water.



EXCELLENT LINE

The control box of the Excellent series is standard equipped with:

Automatic cleaning: floor switch. **Manual operation:** turn button / rinse. **Drum flushing time:** 10 sec. **Flushing level (gravity-fed):** adjustable. **Flushing level (pump-fed):** not adjustable. **Power outlets:** flushing pump, pond pump, drum drive motor and UVC HO 40 W or 80 W (stainless steel). **Dry-run protection deactivation:** 30 sec (UVC lamp). **Flush protection:** after 5 minutes of continuous flushing, the control box switches off, manual reset required. **Magnetic safety switch:** opening the lid switches off the control box.

Technical specifications



Product	BIO DRUM 15 S GRAVITY	BIO DRUM 15 S PUMP
Length x width x height	1053 X 530 X 498mm	1053 X 530 X 498mm
Drum	Ø 400 x 400mm	Ø 400 x 400mm
Mesh size screen (PP) with stainless steel (SS) mesh	120 µm	120 µm
Max. Flow	15 m ³	10,5 m ³
Max. pond volume	20 m ³	15 m ³
Max. pond volume with koi	15 m ³	10,5 m ³
Inlet (mm)	2 x 110mm	2 x 110mm
Outlet (mm)	2 x 110mm	2 x 110mm
Internal flushing pump	SS, 4 bar / 750 W, 220 V	SS, 4 bar / 750 W, 220 V
Industrial motor	130Nm /60 watt 220volt	130Nm /60 watt 220volt
Built-in UVC unit	40 watt H-O	40 watt H-O
Control box	including	including
Item no.	WMC06DRG	WMC06DRP

Spare parts & biological filter media

Product	Item no.
Replacement UV-C HO 40 W lamp for stainless steel (SS) housing	RLM0020
Quartz glass HO 40 W	QS0001
Electrical unit for Inox Excellent 40 watt	EPM0001EX
Sieve panel 1 x 1140 x 200mm Ø 40	ZS00006EX



Discover the complete Excellent series

Bio Drum 25 M

Evolved and optimized

Through the acquisition and practical application of knowledge, a new and unique filter series has been developed. Existing technologies have been further refined and optimized. We proudly present our high-quality filter: the Filtreau Excellent series. This series can be easily expanded with an optional UV-C HO 40/80 watt unit, allowing for a fully configurable system that contributes to a clear and clean pond. It supports the breakdown of ammonia, nitrite and nitrate. As the Filtreau Excellent filters are entirely developed in-house, every aspect has been carefully considered.

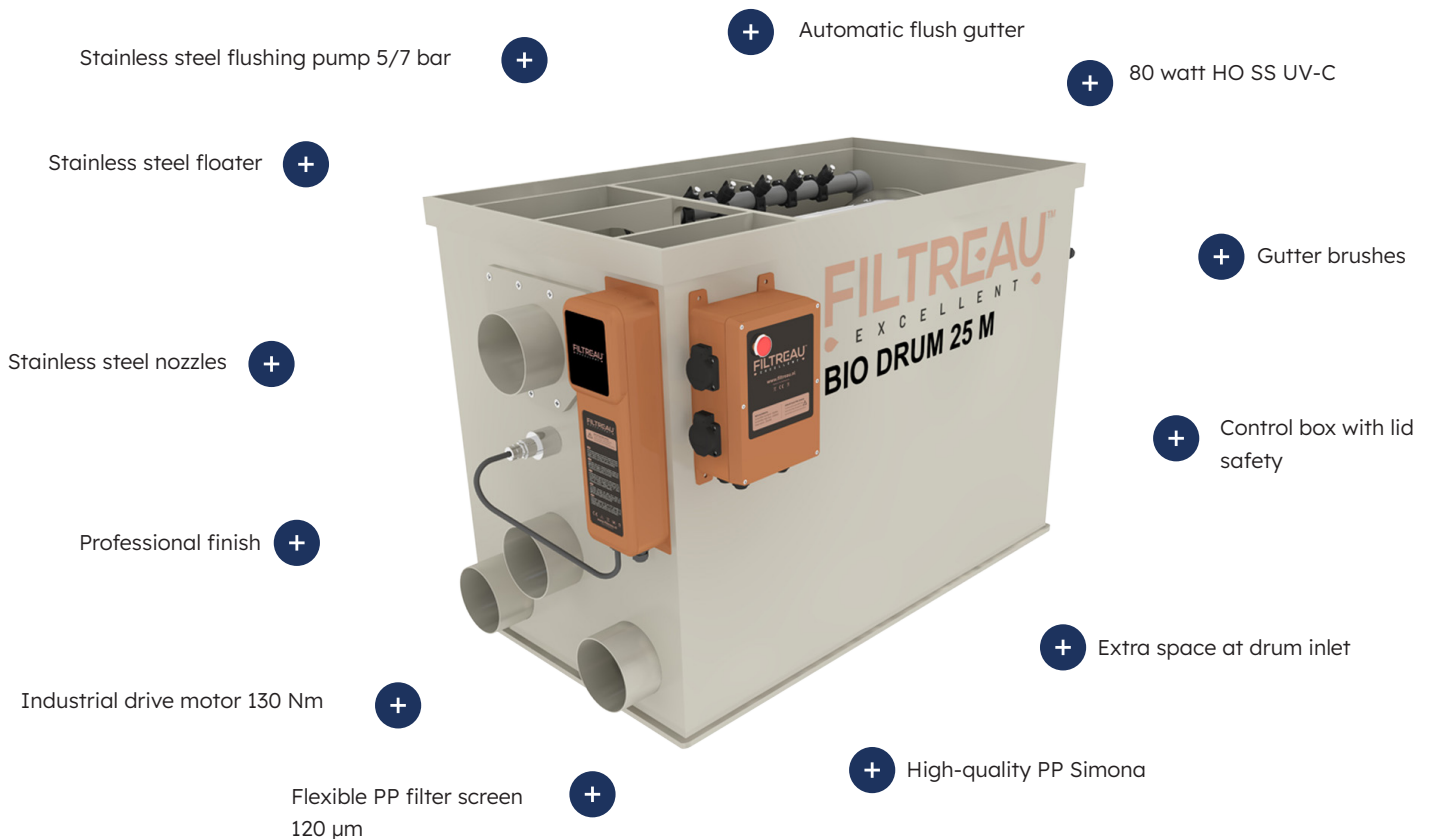

Drum filter

A pre-filter is a drum filter that efficiently removes very fine debris (120 µm) from the water. The water enters the drum filter either pump-fed or gravity-fed, where contaminants are separated from the water. The water flows from the inside of the drum through the filter screen to the outside of the unit. The debris remains on the sieve panel (PP), which is mounted on the drum. The sieve panel (PP) is fitted with a fine stainless steel mesh (120 µm)

The debris is rinsed off the sieve panel (PP) by means of stainless steel nozzles and collected in the gutter. The gutter flushing system ensures that the contaminants are discharged towards the outlet. The cleaning frequency depends on the level of contamination of the pond water.



EXCELLENT LINE

The control box of the Excellent series is standard equipped with:

Automatic cleaning: floor switch. **Manual operation:** turn button / rinse. **Drum flushing time:** 10 sec. **Flushing level (gravity-fed):** adjustable. **Flushing level (pump-fed):** not adjustable. **Power outlets:** flushing pump, pond pump, drum drive motor and UVC HO 40 W or 80 W (stainless steel). **Dry-run protection deactivation:** 30 sec (UVC lamp). **Flush protection:** after 5 minutes of continuous flushing, the control box switches off, manual reset required. **Magnetic safety switch:** opening the lid switches off the control box.

Technical specifications



Product	BIO DRUM 25 M GRAVITY	BIO DRUM 25 M PUMP
Length x width x height	1163 x 530 x 680mm	1163 x 530 x 680mm
Drum	Ø 400 x 400mm	Ø 400 x 400mm
Mesh size screen (PP) with stainless steel (SS) mesh	120 µm	120 µm
Max. Flow	25 m ³	20 m ³
Max. pond volume	50 m ³	40 m ³
Max. pond volume with koi	25 m ³	20 m ³
Inlet (mm)	3 x 110mm	3 x 110mm
Outlet (mm)	2 x 110mm	2 x 110mm
Internal flushing pump	SS 5 bar/750 watt 220V	SS 5 bar/750 watt 220V
Industrial motor	130Nm/60 watt 220V	130Nm/60 watt 220V
Built-in UVC unit	80 watt H-O	80 watt H-O
Control box	including	including
Item no.	WMC01DRG	WMC01DRP

Spare parts & biological filter media

Product	Item no.
Replacement UV-C HO 80 W lamp for SS housing	RLM0021
HO 80 W quartz sleeve	QS0006
Inox Excellent 80 watt electrical unit	EPM0003EX
Sieve panel 1 x 1140 x 400mm Ø 40	ZS00005EX



Discover the complete Excellent series

Bio Drum 35 L

Evolved and optimized

Through the acquisition and practical application of knowledge, a new and unique filter series has been developed. Existing technologies have been further refined and optimized. We proudly present our high-quality filter: the Filtreau Excellent series. This series can be easily expanded with an optional UV-C HO 40/80 watt unit, allowing for a fully configurable system that contributes to a clear and clean pond. It supports the breakdown of ammonia, nitrite and nitrate. As the Filtreau Excellent filters are entirely developed in-house, every aspect has been carefully considered.

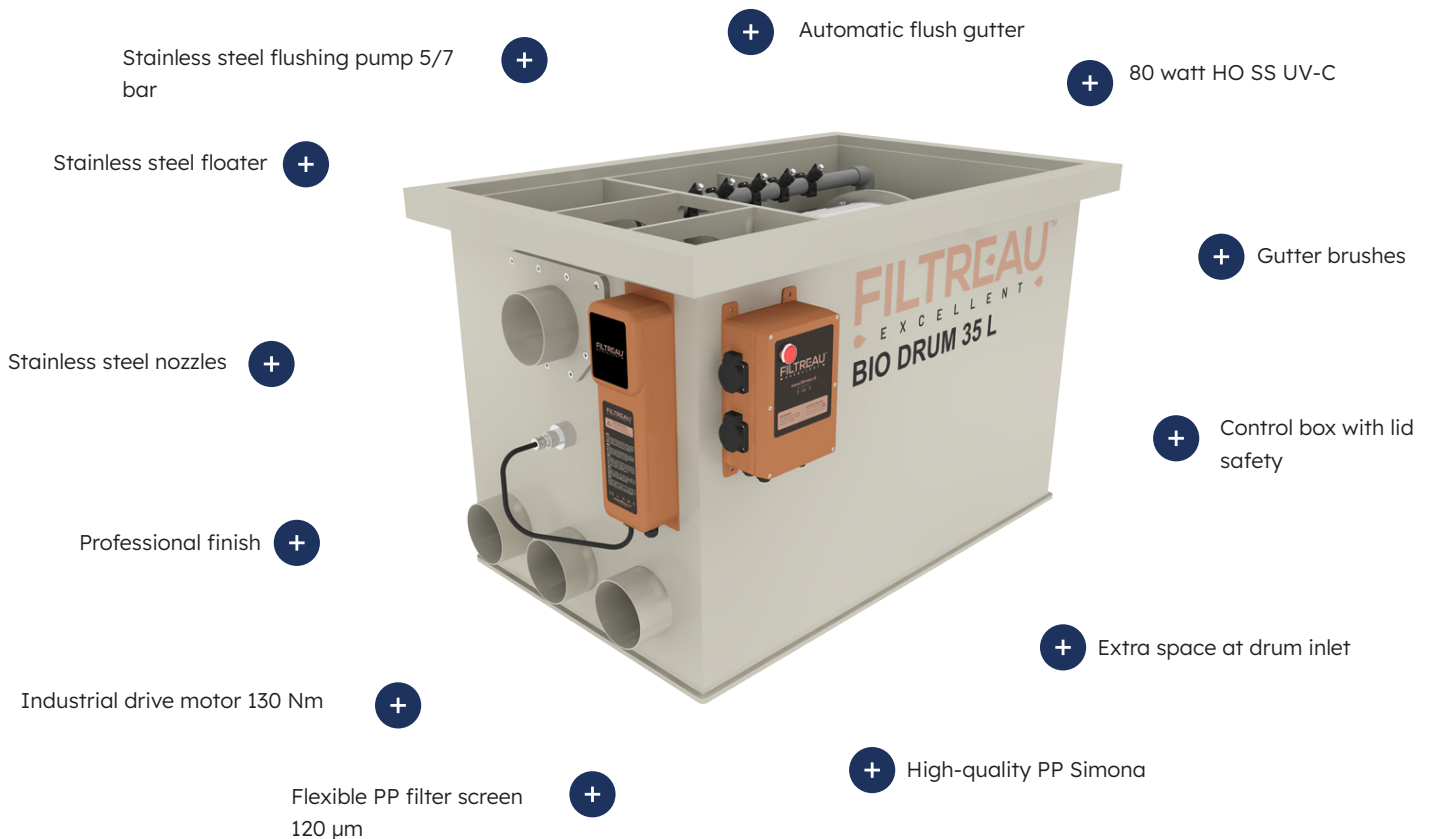

Drum filter

A pre-filter is a drum filter that efficiently removes very fine debris (120 µm) from the water. The water enters the drum filter either pump-fed or gravity-fed, where contaminants are separated from the water. The water flows from the inside of the drum through the filter screen to the outside of the unit. The debris remains on the sieve panel (PP), which is mounted on the drum. The sieve panel (PP) is fitted with a fine stainless steel mesh (120 µm)

The debris is rinsed off the sieve panel (PP) by means of stainless steel nozzles and collected in the gutter. The gutter flushing system ensures that the contaminants are discharged towards the outlet. The cleaning frequency depends on the level of contamination of the pond water.



EXCELLENT LINE

The control box of the Excellent series is standard equipped with:

Automatic cleaning: floor switch. **Manual operation:** turn button / rinse. **Drum flushing time:** 10 sec. **Flushing level (gravity-fed):** adjustable. **Flushing level (pump-fed):** not adjustable. **Power outlets:** flushing pump, pond pump, drum drive motor and UVC HO 40 W or 80 W (stainless steel). **Dry-run protection deactivation:** 30 sec (UVC lamp). **Flush protection:** after 5 minutes of continuous flushing, the control box switches off, manual reset required. **Magnetic safety switch:** opening the lid switches off the control box.

Technical specifications



Product	BIO DRUM 35 L GRAVITY	BIO DRUM 35 L PUMP
Length x width x height	1163 x 700 x 680mm	1163 x 700 x 680mm
Drum	Ø 500 x 400mm	Ø 500 x 400mm
Mesh size screen (PP) with stainless steel (SS) mesh	120 µm	120 µm
Max. Flow	35 m ³	25 m ³
Max. pond volume	70 m ³	50 m ³
Max. pond volume with koi	35 m ³	25 m ³
Inlet (mm)	3 x 110mm	3 x 110mm
Outlet (mm)	3 x 110mm	3 x 110mm
Internal flushing pump	SS 5 bar/750 watt 220V	SS 5 bar/750 watt 220V
Industrial motor	130Nm/60 watt 220V	130Nm/60 watt 220V
Built-in UVC unit	80 watt H-O	80 watt H-O
Control box	including	including
Item no.	WMC02DRG	WMC02DRP

Spare parts & biological filter media

Product	Item no.
Replacement UV-C HO 80 W lamp for SS housing	RLM0021
HO 80 W quartz sleeve	QS0006
Inox Excellent 80 watt electrical unit	EPM0003EX
Sieve panel 2 x 750 x 400mm Ø 50	ZS00006EX



Discover the
complete Excellent
series

Bio Drum 60 XL

Evolved and optimized

Through the acquisition and practical application of knowledge, a new and unique filter series has been developed. Existing technologies have been further refined and optimized. We proudly present our high-quality filter: the Filtreau Excellent series. This series can be easily expanded with an optional UV-C HO 40/80 watt unit, allowing for a fully configurable system that contributes to a clear and clean pond. It supports the breakdown of ammonia, nitrite and nitrate. As the Filtreau Excellent filters are entirely developed in-house, every aspect has been carefully considered.

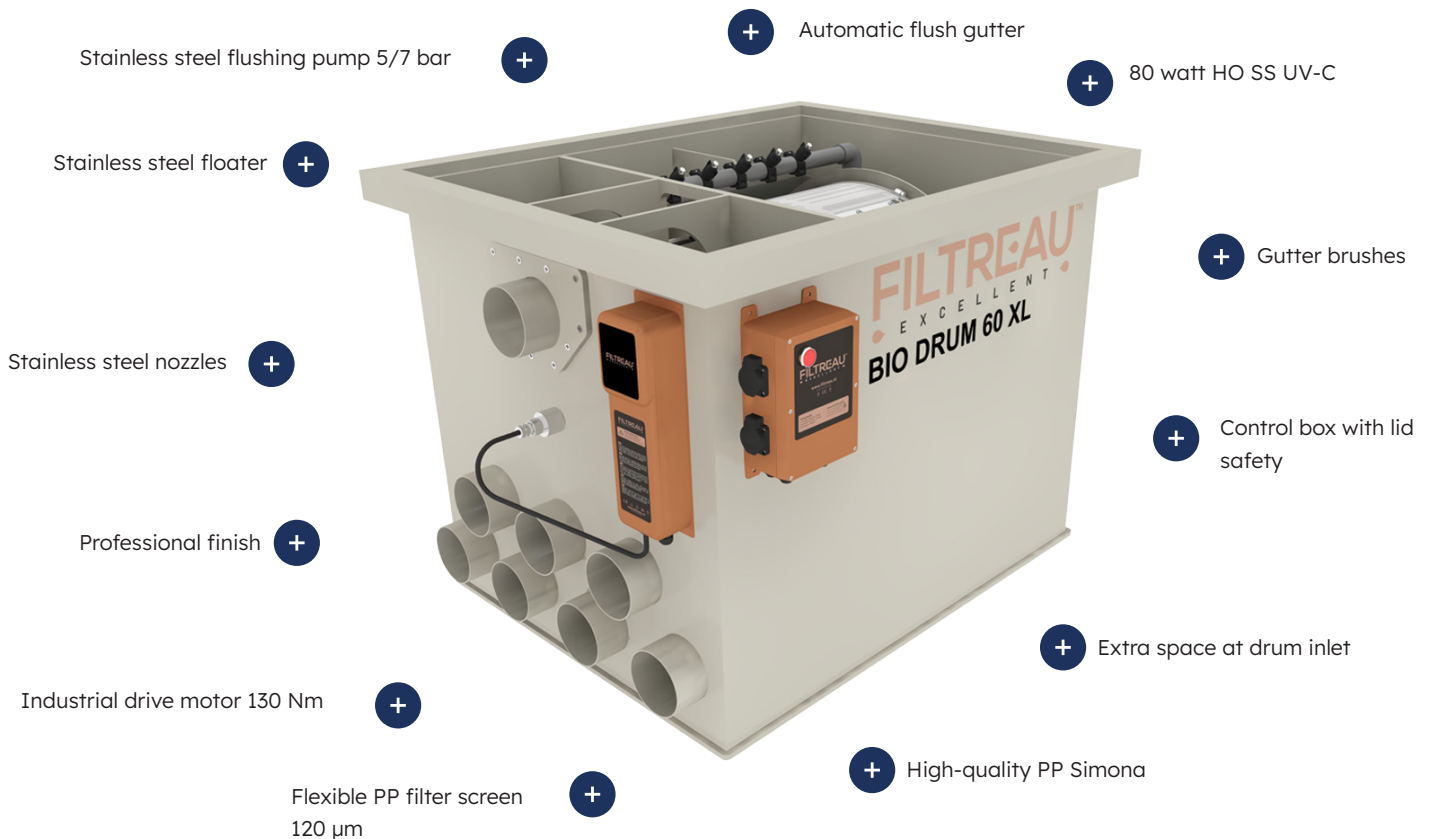

Drum filter

A pre-filter is a drum filter that efficiently removes very fine debris (120 µm) from the water. The water enters the drum filter either pump-fed or gravity-fed, where contaminants are separated from the water. The water flows from the inside of the drum through the filter screen to the outside of the unit. The debris remains on the sieve panel (PP), which is mounted on the drum. The sieve panel (PP) is fitted with a fine stainless steel mesh (120 µm)

The debris is rinsed off the sieve panel (PP) by means of stainless steel nozzles and collected in the gutter. The gutter flushing system ensures that the contaminants are discharged towards the outlet. The cleaning frequency depends on the level of contamination of the pond water.



EXCELLENT LINE

The control box of the Excellent series is standard equipped with:

Automatic cleaning: floor switch. **Manual operation:** turn button / rinse. **Drum flushing time:** 10 sec. **Flushing level (gravity-fed):** adjustable. **Flushing level (pump-fed):** not adjustable. **Power outlets:** flushing pump, pond pump, drum drive motor and UVC HO 40 W or 80 W (stainless steel). **Dry-run protection deactivation:** 30 sec (UVC lamp). **Flush protection:** after 5 minutes of continuous flushing, the control box switches off, manual reset required. **Magnetic safety switch:** opening the lid switches off the control box.

Technical specifications



Product	BIO DRUM 60 XL GRAVITY	BIO DRUM 60 XL PUMP
Length x width x height	1163 x 850 x 780mm	1163 x 850 x 780mm
Drum	Ø 650 x 400mm	Ø 650 x 400mm
Mesh size screen (PP) with stainless steel (SS) mesh	120 µm	120 µm
Max. Flow	60 m ³	45 m ³
Max. pond volume	120 m ³	90 m ³
Max. pond volume with koi	60 m ³	45 m ³
Inlet (mm)	7 x 110mm	7 x 110mm
Outlet (mm)	4 x 110mm	4 x 110mm
Internal flushing pump	SS 5 bar/750 watt 220V	SS 5 bar/750 watt 220V
Industrial motor	130Nm/60 watt 220V	130Nm/60 watt 220V
Built-in UVC unit	80 watt H-O	80 watt H-O
Control box	including	including
Item no.	WMC03DRG	WMC03DRP

Spare parts & biological filter media

Product	Item no.
Replacement UV-C HO 80 W lamp for SS housing	RLM0021
HO 80 W quartz sleeve	QS0006
Inox Excellent 80 watt electrical unit	EPM0003EX
Sieve panel 4 x 1000 x 400mm Ø 65	ZS00007EX



Discover the complete Excellent series

Bio Drum 100 XXL

Evolved and optimized

Through the acquisition and practical application of knowledge, a new and unique filter series has been developed. Existing technologies have been further refined and optimized. We proudly present our high-quality filter: the Filtreau Excellent series. This series can be easily expanded with an optional UV-C HO 40/80 watt unit, allowing for a fully configurable system that contributes to a clear and clean pond. It supports the breakdown of ammonia, nitrite and nitrate. As the Filtreau Excellent filters are entirely developed in-house, every aspect has been carefully considered.

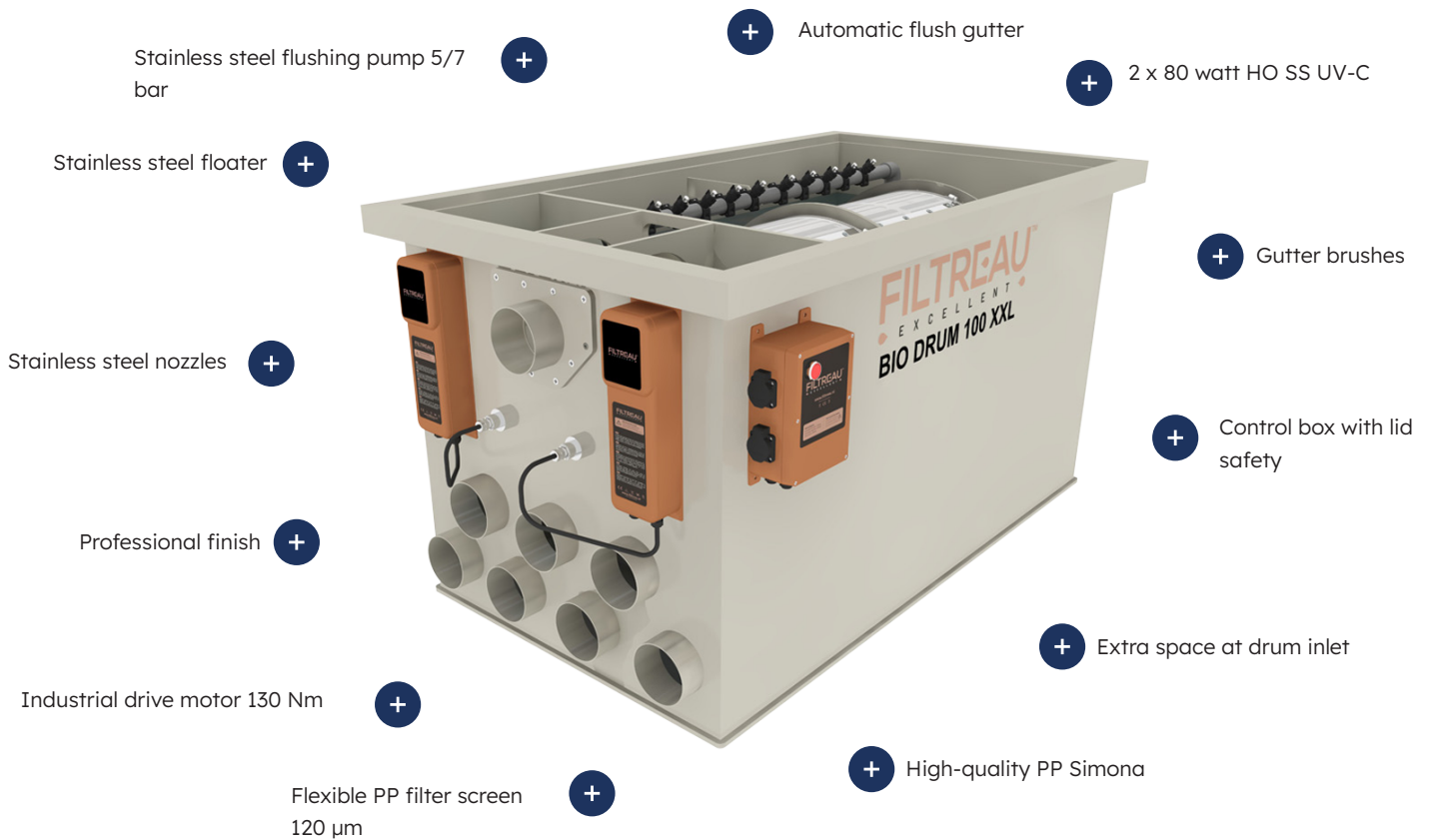

Drum filter

A pre-filter is a drum filter that efficiently removes very fine debris (120 µm) from the water. The water enters the drum filter either pump-fed or gravity-fed, where contaminants are separated from the water. The water flows from the inside of the drum through the filter screen to the outside of the unit. The debris remains on the sieve panel (PP), which is mounted on the drum. The sieve panel (PP) is fitted with a fine stainless steel mesh (120 µm)

The debris is rinsed off the sieve panel (PP) by means of stainless steel nozzles and collected in the gutter. The gutter flushing system ensures that the contaminants are discharged towards the outlet. The cleaning frequency depends on the level of contamination of the pond water.



EXCELLENT LINE

The control box of the Excellent series is standard equipped with:

Automatic cleaning: floor switch. **Manual operation:** turn button / rinse. **Drum flushing time:** 10 sec. **Flushing level (gravity-fed):** adjustable. **Flushing level (pump-fed):** not adjustable. **Power outlets:** flushing pump, pond pump, drum drive motor and UVC HO 40 W or 80 W (stainless steel). **Dry-run protection deactivation:** 30 sec (UVC lamp). **Flush protection:** after 5 minutes of continuous flushing, the control box switches off, manual reset required. **Magnetic safety switch:** opening the lid switches off the control box.

Technical specifications



Product	BIO DRUM 100 XXL GRAVITY	BIO DRUM 100 XXL PUMP
Length x width x height	1575 x 850 x 780mm	1575 x 850 x 780mm
Drum	Ø 650 x 800mm	Ø 650 x 800mm
Mesh size screen (PP) with stainless steel (SS) mesh	120 µm	120 µm
Max. Flow	100 m ³	75 m ³
Max. pond volume	200 m ³	150 m ³
Max. pond volume with koi	100 m ³	75 m ³
Inlet (mm)	7 x 110mm	7 x 110mm
Outlet (mm)	4 x 110mm	4 x 110mm
Internal flushing pump	SS 5 bar/750 watt 220V	SS 5 bar/750 watt 220V
Industrial motor	130Nm/60 watt 220V	130Nm/60 watt 220V
Built-in UVC unit	2 x 80 watt H-O	2 x 80 watt H-O
Control box	including	including
Item no.	WMC04DRG	WMC04DRP

Spare parts & biological filter media

Product	Item no.
Replacement UV-C HO 80 W lamp for SS housing	RLM0021
HO 80 W quartz sleeve	QS0006
Inox Excellent 80 watt electrical unit	EPM0003EX
Sieve panel 4 x 1000 x 400mm Ø 65	ZS00007EX



Discover the complete Excellent series

Bio Drum 40 Ultra

Evolved and optimized

Through the acquisition and practical application of knowledge, a new and unique filter series has been developed. Existing technologies have been further refined and optimized. We proudly present our high-quality filter: the Filtreau Excellent series. This series can be easily expanded with an optional UV-C HO 40/80 watt unit, allowing for a fully configurable system that contributes to a clear and clean pond. It supports the breakdown of ammonia, nitrite and nitrate. As the Filtreau Excellent filters are entirely developed in-house, every aspect has been carefully considered.

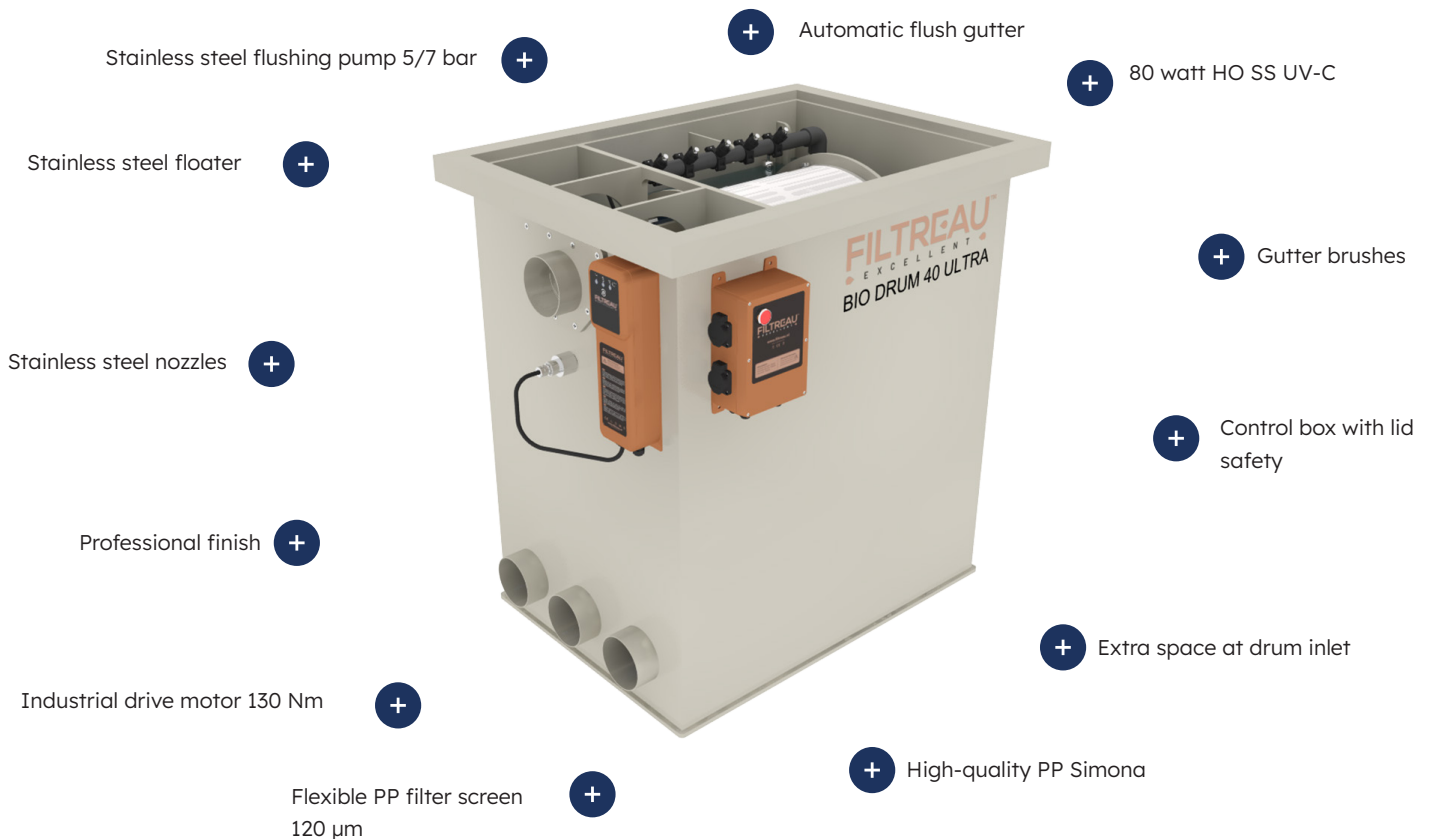

Drum filter

A pre-filter is a drum filter that efficiently removes very fine debris (120 µm) from the water. The water enters the drum filter either pump-fed or gravity-fed, where contaminants are separated from the water. The water flows from the inside of the drum through the filter screen to the outside of the unit. The debris remains on the sieve panel (PP), which is mounted on the drum. The sieve panel (PP) is fitted with a fine stainless steel mesh (120 µm)

The debris is rinsed off the sieve panel (PP) by means of stainless steel nozzles and collected in the gutter. The gutter flushing system ensures that the contaminants are discharged towards the outlet. The cleaning frequency depends on the level of contamination of the pond water.



EXCELLENT LINE

The control box of the Excellent series is standard equipped with:

Automatic cleaning: floor switch. **Manual operation:** turn button / rinse. **Drum flushing time:** 10 sec. **Flushing level (gravity-fed):** adjustable. **Flushing level (pump-fed):** not adjustable. **Power outlets:** flushing pump, pond pump, drum drive motor and UVC HO 40 W or 80 W (stainless steel). **Dry-run protection deactivation:** 30 sec (UVC lamp). **Flush protection:** after 5 minutes of continuous flushing, the control box switches off, manual reset required. **Magnetic safety switch:** opening the lid switches off the control box.

Technical specifications



Product	BIO DRUM 40 Ultra Sieve GRAVITY	BIO DRUM 40 Ultra Sieve PUMP
Length x width x height	1090 x 700 x 980mm	1090 x 700 x 980mm
Drum	Ø 400 x 400mm	Ø 400 x 400mm
Mesh size screen (PP) with stainless steel (SS) mesh	120 µm	120 µm
Max. Flow	30 m ³	22,5 m ³
Max. pond volume	60 m ³	45 m ³
Max. pond volume with koi	120 m ³	90 m ³
Inlet (mm)	3 x 110mm	3 x 110mm
Outlet (mm)	3 x 110mm	3 x 110mm
Internal flushing pump	SS 5 bar / 750watt 220 volt	SS 5 bar / 750watt 220 volt
Industrial motor	130Nm /60 watt 220volt	130Nm /60 watt 220volt
Built-in UVC unit	80 watt H-O	80 watt H-O
Control box	including	including
Item no.	WMC07DRG	WMC07DRP

Spare parts & biological filter media

Product	Item no.
Replacement lampUV-C HO 80 watt	RLM0021
HO 80 W quartz sleeve	QS0006
Inox Excellent 80 watt electrical unit	EPM0003EX



Discover the complete Excellent series

Combi Drum 10/15 Low

Evolved and optimized

Through the acquisition and practical application of knowledge, a new and unique filter series has been developed. Existing technologies have been further refined and optimized. We proudly present our high-quality filter: the Filtreau Excellent series. This series can be easily expanded with an optional UV-C HO 40/80 watt unit, allowing for a fully configurable system that contributes to a clear and clean pond. It supports the breakdown of ammonia, nitrite and nitrate. As the Filtreau Excellent filters are entirely developed in-house, every aspect has been carefully considered.

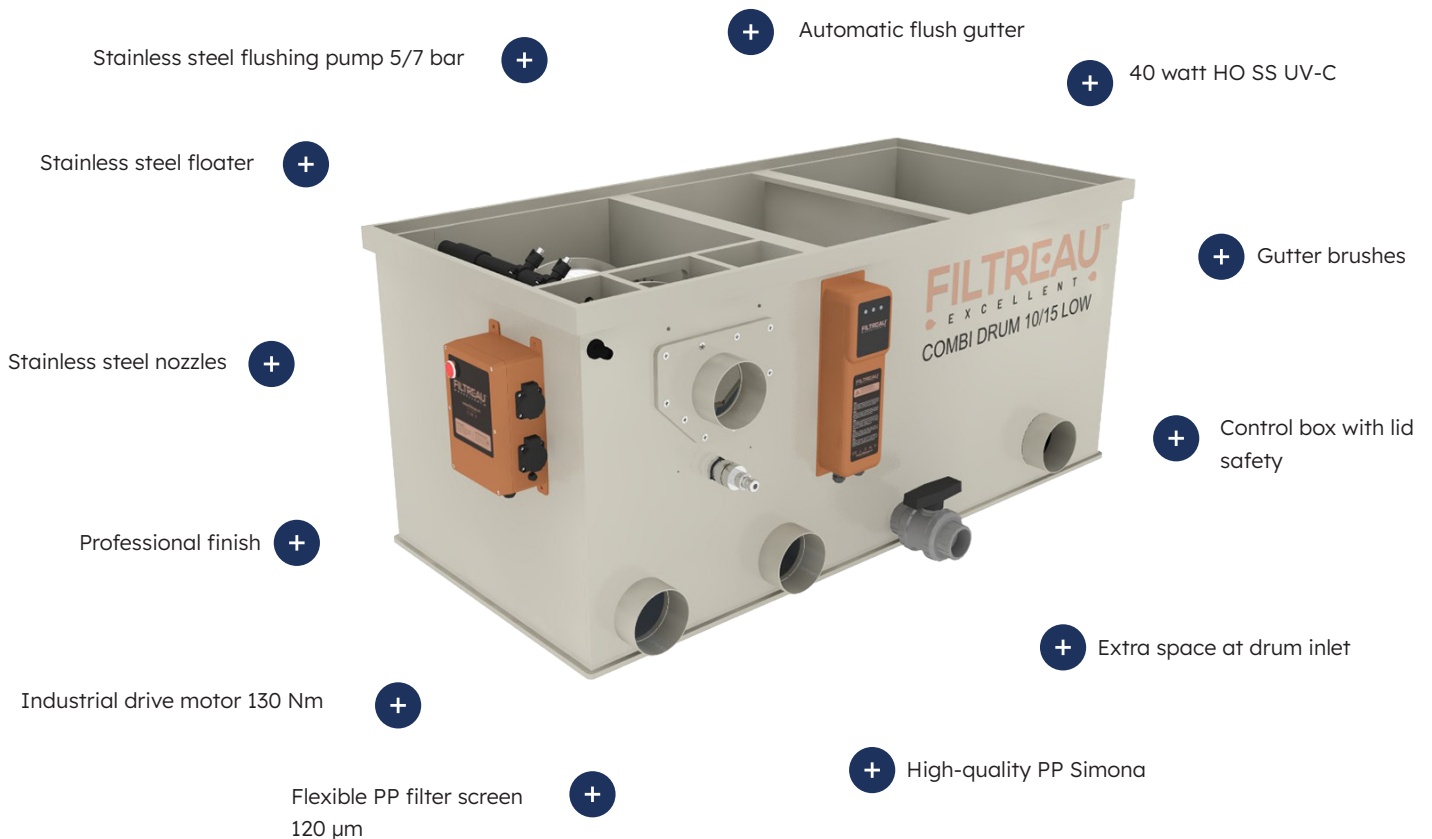

Drum filter

A pre-filter is a drum filter that efficiently removes very fine debris (120 µm) from the water. The water enters the drum filter either pump-fed or gravity-fed, where contaminants are separated from the water. The water flows from the inside of the drum through the filter screen to the outside of the unit. The debris remains on the sieve panel (PP), which is mounted on the drum. The sieve panel (PP) is fitted with a fine stainless steel mesh (120 µm)

The debris is rinsed off the sieve panel (PP) by means of stainless steel nozzles and collected in the gutter. The gutter flushing system ensures that the contaminants are discharged towards the outlet. The cleaning frequency depends on the level of contamination of the pond water.



EXCELLENT LINE

The control box of the Excellent series is standard equipped with:

Automatic cleaning: floor switch. **Manual operation:** turn button / rinse. **Drum flushing time:** 10 sec. **Flushing level (gravity-fed):** adjustable. **Flushing level (pump-fed):** not adjustable. **Power outlets:** flushing pump, pond pump, drum drive motor and UVC HO 40 W or 80 W (stainless steel). **Dry-run protection deactivation:** 30 sec (UVC lamp). **Flush protection:** after 5 minutes of continuous flushing, the control box switches off, manual reset required. **Magnetic safety switch:** opening the lid switches off the control box.

Technical specifications



Product	COMBI DRUM 10/15 LOW GRAVITY
Length x width x height	1350 x 852 x 598 mm
Drum	Ø 400 x 200mm
Mesh size screen (PP) with stainless steel (SS) mesh	120 µm
Max. Flow	15 m ³
Max. pond volume	25 m ³
Max. pond volume with koi	15 m ³
Inlet (mm)	2 x 110mm
Outlet (mm)	1 x 110mm
Internal flushing pump	SS 4 bar / 750watt 220 volt
Industrial motor	130Nm /60 watt 220volt
Built-in UVC unit	40 watt H-O
Control box	including
Item no.	WMC08PPG

Spare parts & biological filter media

Product	Item no.
Replacement UV-C HO 40 W lamp for stainless steel (SS) housing	RLM0020
Quartz glass HO 40 W	QS0001
Electrical unit for Inox Excellent 40 watt	EPM0001EX
Sieve panel 1 x 1140 x 200mm Ø 40	ZS00006EX
1 m ² Japanese mat, 50 mm, open surface area 645 m ² /m ³	3001484
Hel-X 13x12mm 955m ² m ³ 30 liter	3001139



Discover the complete Excellent series

Bio Drum 20/25

Evolved and optimized

Through the acquisition and practical application of knowledge, a new and unique filter series has been developed. Existing technologies have been further refined and optimized. We proudly present our high-quality filter: the Filtreau Excellent series. This series can be easily expanded with an optional UV-C HO 40/80 watt unit, allowing for a fully configurable system that contributes to a clear and clean pond. It supports the breakdown of ammonia, nitrite and nitrate. As the Filtreau Excellent filters are entirely developed in-house, every aspect has been carefully considered.

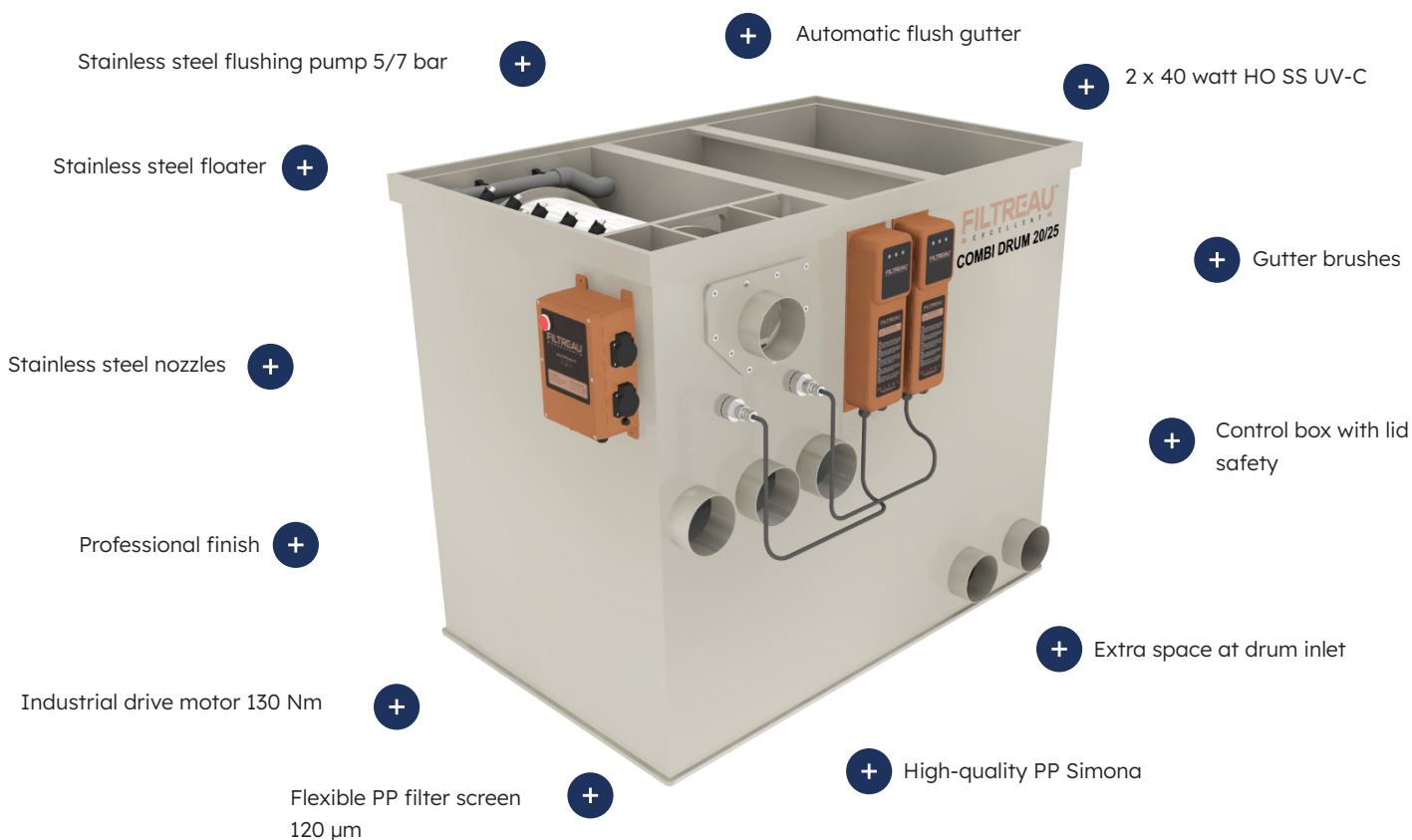

Drum filter

A pre-filter is a drum filter that efficiently removes very fine debris (120 µm) from the water. The water enters the drum filter either pump-fed or gravity-fed, where contaminants are separated from the water. The water flows from the inside of the drum through the filter screen to the outside of the unit. The debris remains on the sieve panel (PP), which is mounted on the drum. The sieve panel (PP) is fitted with a fine stainless steel mesh (120 µm)

The debris is rinsed off the sieve panel (PP) by means of stainless steel nozzles and collected in the gutter. The gutter flushing system ensures that the contaminants are discharged towards the outlet. The cleaning frequency depends on the level of contamination of the pond water.



EXCELLENT LINE

The control box of the Excellent series is standard equipped with:

Automatic cleaning: floor switch. **Manual operation:** turn button / rinse. **Drum flushing time:** 10 sec. **Flushing level (gravity-fed):** adjustable. **Flushing level (pump-fed):** not adjustable. **Power outlets:** flushing pump, pond pump, drum drive motor and UVC HO 40 W or 80 W (stainless steel). **Dry-run protection deactivation:** 30 sec (UVC lamp). **Flush protection:** after 5 minutes of continuous flushing, the control box switches off, manual reset required. **Magnetic safety switch:** opening the lid switches off the control box.

Technical specifications



Product	COMBI DRUM 20/25 GRAVITY	COMBI DRUM 20/25 PUMP	TRICKLE FOR COMBI DRUM 20/25
Length x width x height	1200 x 750 x 98,5mm	1200 x 750 x 98,5mm	660 x 320 x 882mm
Drum	Ø 400 x 400mm	Ø 650 x 800mm	Distribution box
Mesh size screen (PP) with stainless steel (SS) mesh	120 µm	120 µm	
Max. Flow	25 m ³	20 m ³	20 m ³
Max. pond volume	50 m ³	40 m ³	
Max. pond volume with koi	25 m ³	20 m ³	
Inlet (mm)	3 x 110mm	3 x 110mm	63mm
Outlet (mm)	2 x 110mm	2 x 110mm	
Internal flushing pump	SS 4 bar/800 watt 220V	SS 4 bar/800 watt 220V	
Industrial motor	130Nm/60 watt 220V	130Nm/60 watt 220V	
Built-in UVC unit	2 x 40 watt H-O	2 x 40 watt H-O	
Air supply	2 x 50 x 300mm	2 x 50 x 300mm	
Control box	including	including	
Item no.	WMC09PPG	WMC09PPP	WMC09PPT

Spare parts & biological filter media

Product	Item no.
Replacement UV-C HO 40 W lamp for stainless steel (SS) housing	RLM0020
Quartz glass HO 40 W	QS0001
Electrical unit for Inox Excellent 40 watt	EPM0020
Sieve panel 1 x 1140 x 400mm Ø 40	ZS00005EX
1,8m ² Japanese mat 50mm open surface area 645 2m ² /m ³	3001484
Hel-X 13x12mm 955m ² /m ³ 100 liter	3001139



Discover the
complete Excellent
series

Combi Drum 25/30

Evolved and optimized

Through the acquisition and practical application of knowledge, a new and unique filter series has been developed. Existing technologies have been further refined and optimized. We proudly present our high-quality filter: the Filtreau Excellent series. This series can be easily expanded with an optional UV-C HO 40/80 watt unit, allowing for a fully configurable system that contributes to a clear and clean pond. It supports the breakdown of ammonia, nitrite and nitrate. As the Filtreau Excellent filters are entirely developed in-house, every aspect has been carefully considered.

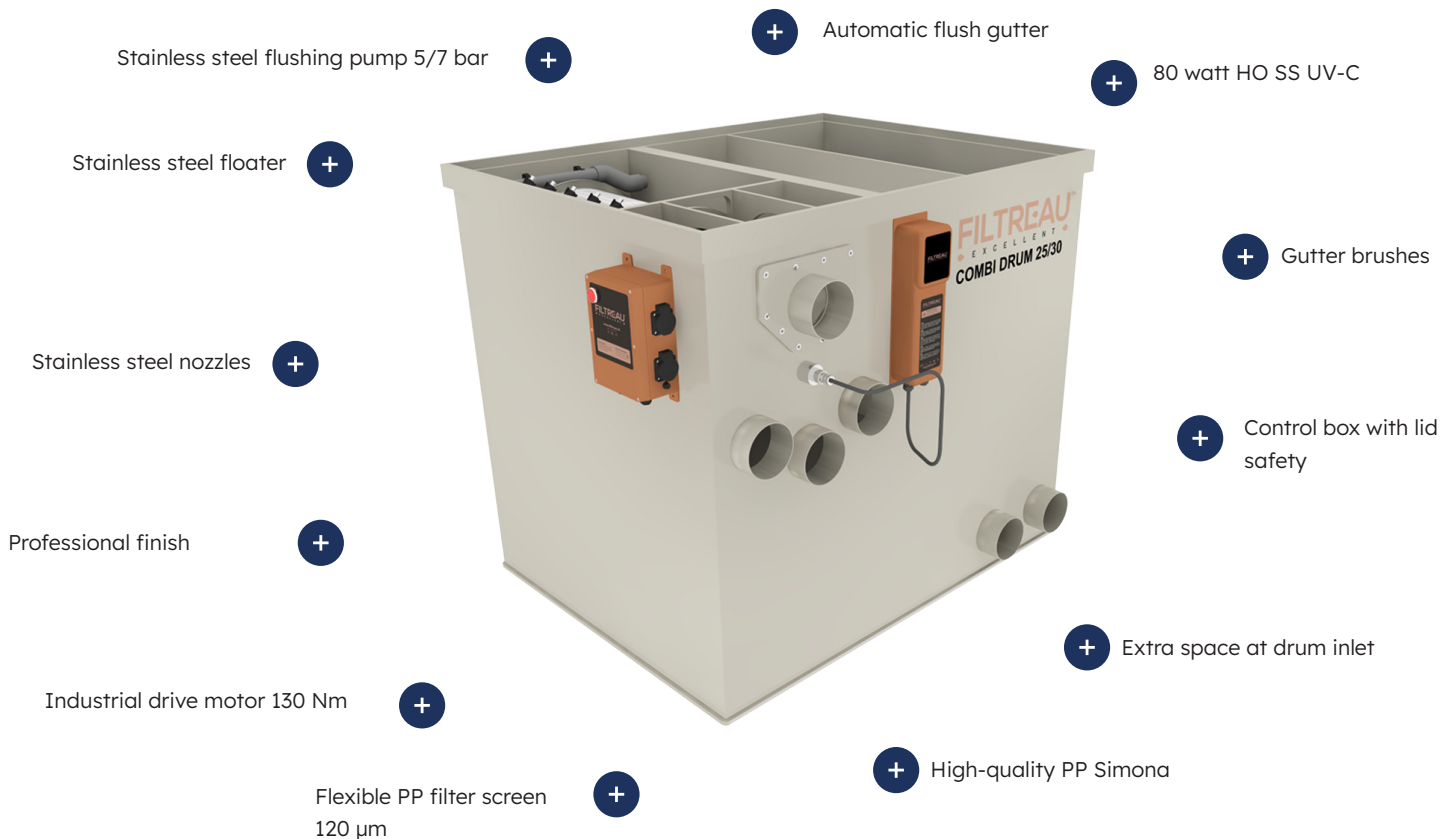

Drum filter

A pre-filter is a drum filter that efficiently removes very fine debris (120 µm) from the water. The water enters the drum filter either pump-fed or gravity-fed, where contaminants are separated from the water. The water flows from the inside of the drum through the filter screen to the outside of the unit. The debris remains on the sieve panel (PP), which is mounted on the drum. The sieve panel (PP) is fitted with a fine stainless steel mesh (120 µm)

The debris is rinsed off the sieve panel (PP) by means of stainless steel nozzles and collected in the gutter. The gutter flushing system ensures that the contaminants are discharged towards the outlet. The cleaning frequency depends on the level of contamination of the pond water.



EXCELLENT LINE

The control box of the Excellent series is standard equipped with:

Automatic cleaning: floor switch. **Manual operation:** turn button / rinse. **Drum flushing time:** 10 sec. **Flushing level (gravity-fed):** adjustable. **Flushing level (pump-fed):** not adjustable. **Power outlets:** flushing pump, pond pump, drum drive motor and UVC HO 40 W or 80 W (stainless steel). **Dry-run protection deactivation:** 30 sec (UVC lamp). **Flush protection:** after 5 minutes of continuous flushing, the control box switches off, manual reset required. **Magnetic safety switch:** opening the lid switches off the control box.

Technical specifications



Product	COMBI DRUM 25/30 GRAVITY	COMBI DRUM 25/30 PUMP	TRICKLE FOR COMBI DRUM 25/30
Length x width x height	1200 x 1117 x 985mm	1200 x 1117 x 985mm	660 x 320 x 882mm
Drum	Ø 400 x 400mm	Ø 400 x 400mm	Distribution box
Mesh size screen (PP) with stainless steel (SS) mesh	120 µm	120 µm	
Max. Flow	30 m ³	20 m ³	20 m ³
Max. pond volume	60 m ³	40 m ³	
Max. pond volume with koi	25 m ³	20 m ³	
Inlet (mm)	3 x 110mm	3 x 110mm	63mm
Outlet (mm)	2 x 110mm	2 x 110mm	
Internal flushing pump	SS 4 bar/800 watt 220V	SS 4 bar/800 watt 220V	
Industrial motor	130Nm/60 watt 220V	130Nm/60 watt 220V	
Built-in UVC unit	80 watt H-O	80 watt H-O	
Air supply	2 x 50 x 300mm	2 x 50 x 300mm	
Control box	including	including	
Item no.	WMC10PPG	WMC10PPP	WMC10PPT

Spare parts & biological filter media

Product	Item no.
Replacement UV-C HO 80 W lamp for SS housing	RLM0021
HO 80 W quartz sleeve	QS0006
Inox Excellent 80 watt electrical unit	EPM0003EX
Sieve panel 1 x 1140 x 400mm Ø 40	ZS00005EX
2m ² Japanese mat 50mm open surface area 645 2m ² /m ³ (optional)	3001484
Hel-X 13x12mm 955m ² /m ³ 100 liter (optional)	3001139



Discover the complete Excellent series

Combi Drum 20/25 LOW

Refined and optimized

Through the acquisition and practical application of knowledge, a new and unique filter series has been developed. Existing technologies have been further refined and optimized. We proudly present our high-quality filter: the Filtreau Excellent series. This series can be easily expanded with an optional UV-C HO 80 W unit, allowing for a fully configurable system that contributes to a clear and clean pond. It supports the breakdown of ammonia, nitrite and nitrate. As the Filtreau Excellent filters are entirely developed in-house, every aspect has been carefully considered.



Drum filter

A pre-filter is a drum filter that efficiently removes very fine debris (120 µm) from the water. The water enters the drum filter either pump-fed or gravity-fed, where contaminants are separated from the water. The water flows from the inside of the drum through the filter screen to the outside of the unit. The debris remains on the sieve panel (PP), which is mounted on the drum. The sieve panel (PP) is fitted with a fine stainless steel mesh (120 µm)

The debris is rinsed off the sieve panel (PP) by means of stainless steel nozzles and collected in the gutter. The gutter flushing system ensures that the contaminants are discharged towards the outlet. The cleaning frequency depends on the level of contamination of the pond water.



EXCELLENT LINE

The control box of the Excellent series is standard equipped with:

Automatic cleaning: floor switch. **Manual operation:** turn button / rinse. **Drum flushing time:** 10 sec. **Flushing level (gravity-fed):** adjustable. **Flushing level (pump-fed):** not adjustable. **Power outlets:** flushing pump, pond pump, drum drive motor and UVC HO 40 W or 80 W (stainless steel). **Dry-run protection deactivation:** 30 sec (UVC lamp). **Flush protection:** after 5 minutes of continuous flushing, the control box switches off, manual reset required. **Magnetic safety switch:** opening the lid switches off the control box.

Technical specifications



Product	COMBI DRUM 20/25 LOW GRAVITY	COMBI DRUM 20/25 LOW PUMP	TRICKLE FOR COMBI DRUM 20/25 LOW
Length x width x height	1160 x 902 x 750mm	1160 x 902 x 750mm	660 x 320 x 822mm
Drum	Ø 400 x 400mm	Ø 400 x 400mm	Distribution box
Mesh size screen (PP) with stainless steel (SS) mesh	120 µm	120 µm	
Max. Flow	25 m ³	20 m ³	20 m ³
Max. pond volume	50 m ³	40 m ³	
Max. pond volume with koi	25 m ³	20 m ³	
Inlet (mm)	3 x 110mm	3 x 110mm	1x 63mm
Outlet (mm)	2 x 110mm	2 x 110mm	
Internal flushing pump	SS 4 bar/800 watt 220V	SS 4 bar/800 watt 220V	
Industrial motor	130Nm/60 watt 220/230V	130Nm/60 watt 220/230V	
Built-in UVC unit	80 watt H-O	80 watt H-O	
Air supply	2 x 50 x 300mm	2 x 50 x 300mm	
Control box	including	including	
Item no.	WMC11PPG	WMC11PPP	WMC11PPT

Spare parts & biological filter media

Product	Item no.
Replacement UV-C HO 80 W lamp for SS housing	RLM0021
HO 80 W quartz sleeve	QS0006
Inox Excellent 80 watt electrical unit	EPM0003EX
Sieve panel 1 x 1140 x 400mm Ø 40	ZS00005EX
2m ² Japanese mat 50mm open surface area 645 2m ² m ³ (optional)	3001484
Hel-X 13x12mm 955m ² m ³ 100 liter (optional)	3001139



Discover the
complete Excellent
series

Combi Drum 25/30 LOW

Refined and optimized

Through the acquisition and practical application of knowledge, a new and unique filter series has been developed. Existing technologies have been further refined and optimized. We proudly present our high-quality filter: the Filtreau Excellent series. This series can be easily expanded with an optional UV-C HO 80 W unit, allowing for a fully configurable system that contributes to a clear and clean pond. It supports the breakdown of ammonia, nitrite and nitrate. As the Filtreau Excellent filters are entirely developed in-house, every aspect has been carefully considered.

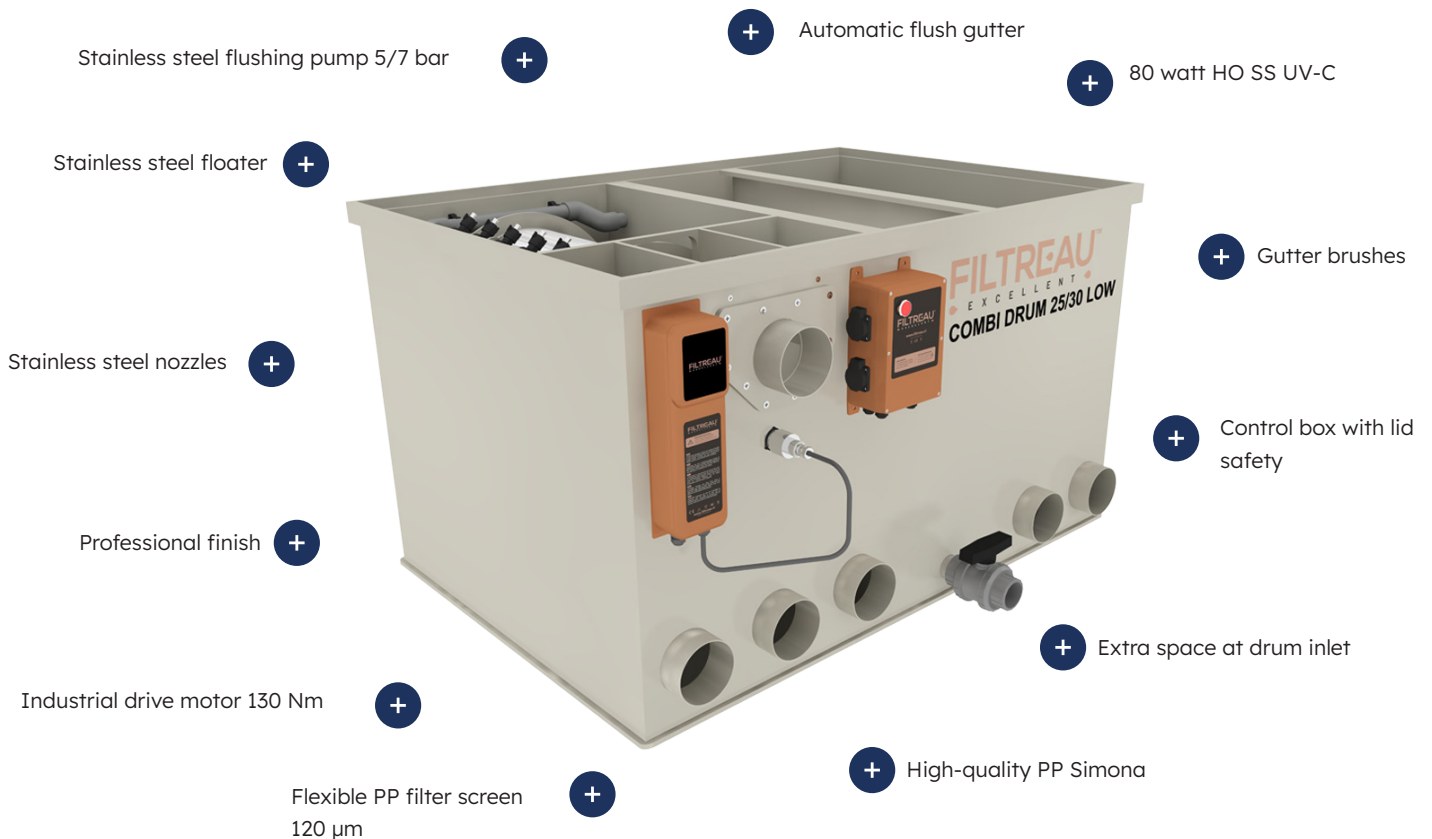

Drum filter

A pre-filter is a drum filter that efficiently removes very fine debris (120 µm) from the water. The water enters the drum filter either pump-fed or gravity-fed, where contaminants are separated from the water. The water flows from the inside of the drum through the filter screen to the outside of the unit. The debris remains on the sieve panel (PP), which is mounted on the drum. The sieve panel (PP) is fitted with a fine stainless steel mesh (120 µm)

The debris is rinsed off the sieve panel (PP) by means of stainless steel nozzles and collected in the gutter. The gutter flushing system ensures that the contaminants are discharged towards the outlet. The cleaning frequency depends on the level of contamination of the pond water.



EXCELLENT LINE

The control box of the Excellent series is standard equipped with:

Automatic cleaning: floor switch. **Manual operation:** turn button / rinse. **Drum flushing time:** 10 sec. **Flushing level (gravity-fed):** adjustable. **Flushing level (pump-fed):** not adjustable. **Power outlets:** flushing pump, pond pump, drum drive motor and UVC HO 40 W or 80 W (stainless steel). **Dry-run protection deactivation:** 30 sec (UVC lamp). **Flush protection:** after 5 minutes of continuous flushing, the control box switches off, manual reset required. **Magnetic safety switch:** opening the lid switches off the control box.

Technical specifications



Product	COMBI DRUM 25/30 LOW GRAVITY	COMBI DRUM 25/30 LOW PUMP	TRICKLE FOR COMBI DRUM 25/30 LOW
Length x width x height	1300 x 1117 x 750mm	1300 x 1117 x 750mm	660 x 320 x 822mm
Drum	Ø 400 x 400mm	Ø 400 x 400mm	Distribution box
Mesh size screen (PP) with stainless steel (SS) mesh	120 µm	120 µm	
Max. Flow	30 m ³	20 m ³	20 m ³
Max. pond volume	60 m ³	40 m ³	
Max. pond volume with koi	30 m ³	20 m ³	
Inlet (mm)	3 x 110mm	3 x 110mm	1x 63mm
Outlet (mm)	2 x 110mm	2 x 110mm	
Internal flushing pump	SS 5 bar/750 watt 220V	SS 5 bar/750 watt 220V	
Industrial motor	130Nm/60 watt 220V	130Nm/60 watt 220V	
Built-in UVC unit	80 watt H-O	80 watt H-O	
Air supply	2 x 50 x 300mm	2 x 50 x 300mm	
Control box	including	including	
Item no.	WMC20CDG	WMC20CDP	WMC20CDT

Spare parts & biological filter media

Product	Item no.
Replacement UV-C HO 80 W lamp for SS housing	RLM0021
HO 80 W quartz sleeve	QS0006
Inox Excellent 80 watt electrical unit	EPM0003EX
Sieve panel 1 x 1140 x 400mm Ø 40	ZS00005EX
2m ² Japanese mat 50mm open surface area 645 2m ² /m ³ (optional)	3001484
Hel-X 13x12mm 955m ² /m ³ 100 liter (optional)	3001139



Discover the
complete Excellent
series

Combi Drum 30/50

Refined and optimized

Through the acquisition and practical application of knowledge, a new and unique filter series has been developed. Existing technologies have been further refined and optimized. We proudly present our high-quality filter: the Filtreau Excellent series. This series can be easily expanded with an optional UV-C HO 80 W unit, allowing for a fully configurable system that contributes to a clear and clean pond. It supports the breakdown of ammonia, nitrite and nitrate. As the Filtreau Excellent filters are entirely developed in-house, every aspect has been carefully considered.

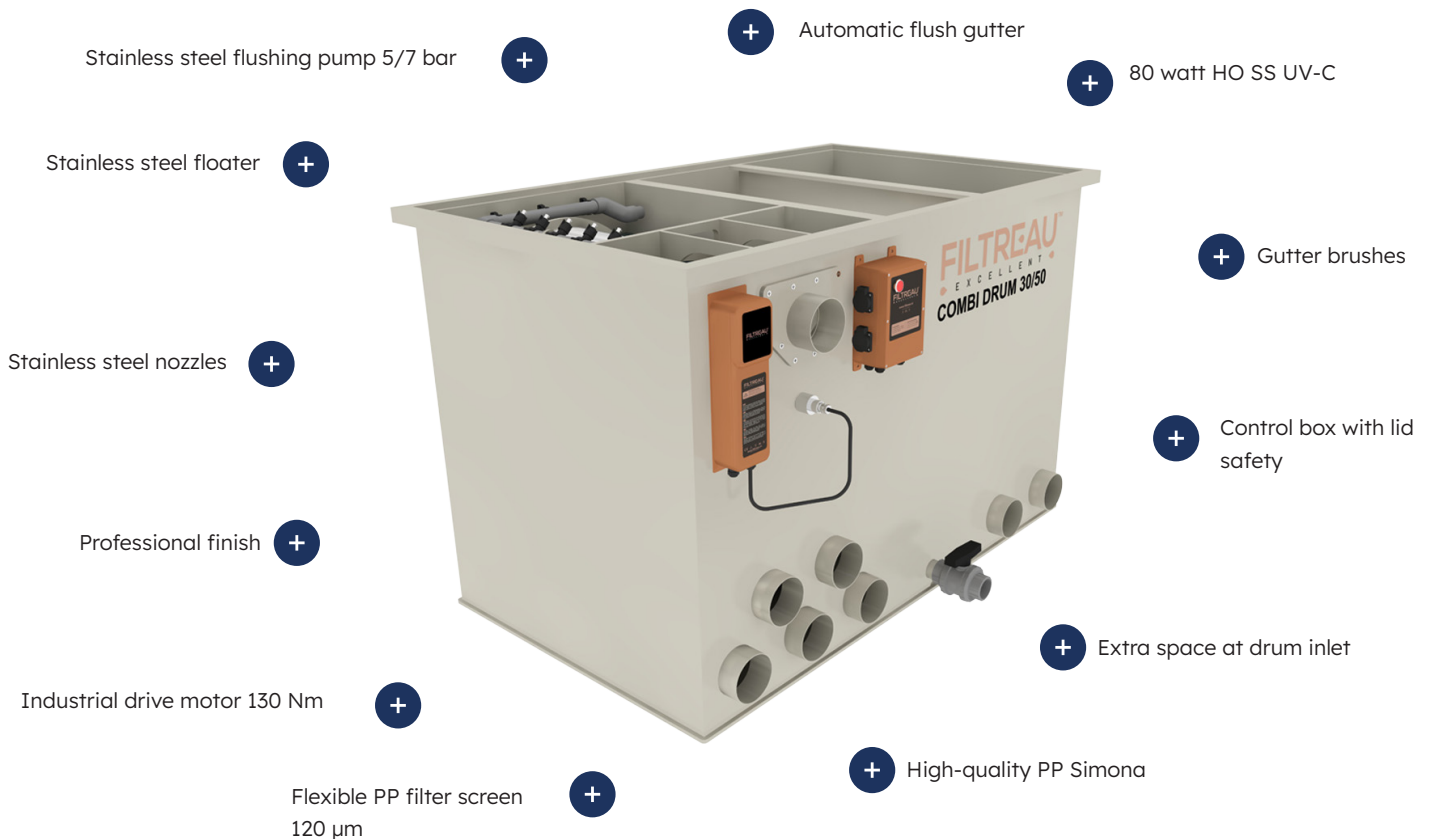

Drum filter

A pre-filter is a drum filter that efficiently removes very fine debris (120 µm) from the water. The water enters the drum filter either pump-fed or gravity-fed, where contaminants are separated from the water. The water flows from the inside of the drum through the filter screen to the outside of the unit. The debris remains on the sieve panel (PP), which is mounted on the drum. The sieve panel (PP) is fitted with a fine stainless steel mesh (120 µm)

The debris is rinsed off the sieve panel (PP) by means of stainless steel nozzles and collected in the gutter. The gutter flushing system ensures that the contaminants are discharged towards the outlet. The cleaning frequency depends on the level of contamination of the pond water.





EXCELLENT LINE

The control box of the Excellent series is standard equipped with:

Automatic cleaning: floor switch. **Manual operation:** turn button / rinse. **Drum flushing time:** 10 sec. **Flushing level (gravity-fed):** adjustable. **Flushing level (pump-fed):** not adjustable. **Power outlets:** flushing pump, pond pump, drum drive motor and UVC HO 40 W or 80 W (stainless steel). **Dry-run protection deactivation:** 30 sec (UVC lamp). **Flush protection:** after 5 minutes of continuous flushing, the control box switches off, manual reset required. **Magnetic safety switch:** opening the lid switches off the control box.

Technical specifications

			
Product	COMBI DRUM 30/50 GRAVITY	COMBI DRUM 30/50 PUMP	TRICKLE FOR COMBI DRUM 30/50
Length x width x height	1510 x 1117 x 995mm	1510 x 1117 x 995mm	870 x 320 x 805mm
Drum	Ø 500 x 400mm	Ø 500 x 400mm	Distribution box
Mesh size screen (PP) with stainless steel (SS) mesh	120 µm	120 µm	
Max. Flow	50 m ³	35 m ³	25 m ³
Max. pond volume	100 m ³	70 m ³	
Max. pond volume with koi	50 m ³	35 m ³	
Inlet (mm)	5 x 110mm	5 x 110mm	1x 63mm
Outlet (mm)	2 x 110mm	2 x 110mm	
Internal flushing pump	SS 5 bar/750 watt 220V	SS 5 bar/750 watt 220V	
Industrial motor	130Nm/60 watt 220V	130Nm/60 watt 220V	
Built-in UVC unit	80 watt H-O	80 watt H-O	
Air supply	2 x 50 x 300mm	2 x 50 x 300mm	
Control box	including	including	
Item no.	WMC21CDG	WMC21CDP	WMC21CDT

Spare parts & biological filter media

Product	Item no.
Replacement UV-C HO 80 W lamp for SS housing	RLM0021
HO 80 W quartz sleeve	QS0006
Inox Excellent 80 watt electrical unit	EPM0003EX
Sieve panel 2x 750 x 400mm Ø 50	ZS00006EX
3m ² Japanese mat 50mm open surface area 645 2m ² m ³ (optional)	3001484
Hel-X 13x12mm 955m ² m ³ 100 liter (optional)	3001139



Discover the complete Excellent series

Combi Drum 50/70

Refined and optimized

Through the acquisition and practical application of knowledge, a new and unique filter series has been developed. Existing technologies have been further refined and optimized. We proudly present our high-quality filter: the Filtreau Excellent series. This series can be easily expanded with an optional UV-C HO 80 W unit, allowing for a fully configurable system that contributes to a clear and clean pond. It supports the breakdown of ammonia, nitrite and nitrate. As the Filtreau Excellent filters are entirely developed in-house, every aspect has been carefully considered.

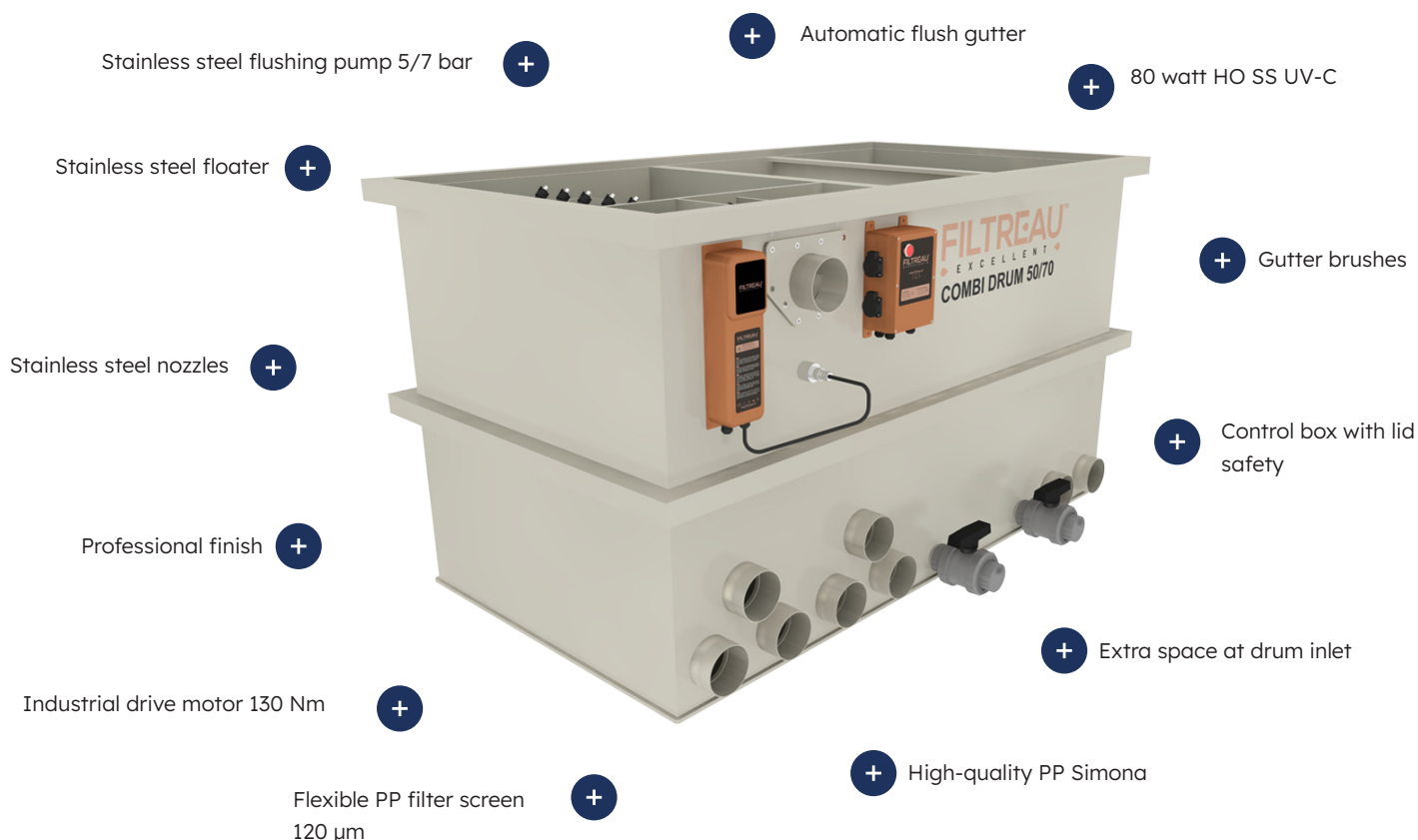

Drum filter

A pre-filter is a drum filter that efficiently removes very fine debris (120 µm) from the water. The water enters the drum filter either pump-fed or gravity-fed, where contaminants are separated from the water. The water flows from the inside of the drum through the filter screen to the outside of the unit. The debris remains on the sieve panel (PP), which is mounted on the drum. The sieve panel (PP) is fitted with a fine stainless steel mesh (120 µm)

The debris is rinsed off the sieve panel (PP) by means of stainless steel nozzles and collected in the gutter. The gutter flushing system ensures that the contaminants are discharged towards the outlet. The cleaning frequency depends on the level of contamination of the pond water.





EXCELLENT LINE

The control box of the Excellent series is standard equipped with:

Automatic cleaning: floor switch. **Manual operation:** turn button / rinse. **Drum flushing time:** 10 sec. **Flushing level (gravity-fed):** adjustable. **Flushing level (pump-fed):** not adjustable. **Power outlets:** flushing pump, pond pump, drum drive motor and UVC HO 40 W or 80 W (stainless steel). **Dry-run protection deactivation:** 30 sec (UVC lamp). **Flush protection:** after 5 minutes of continuous flushing, the control box switches off, manual reset required. **Magnetic safety switch:** opening the lid switches off the control box.

Technical specifications

			
Product	COMBI DRUM 50/70 GRAVITY	COMBI DRUM 50/70 PUMP	TRICKLE FOR COMBI DRUM 50/70
Length x width x height	1825 x 1117 x 1005mm	1825 x 1117 x 1005mm	980 x 320 x 805mm
Drum	Ø 650 x 400mm	Ø 650 x 400mm	Distribution box
Mesh size screen (PP) with stainless steel (SS) mesh	120 µm	120 µm	
Max. Flow	70 m ³	50 m ³	25 m ³
Max. pond volume	140 m ³	100 m ³	
Max. pond volume with koi	70 m ³	50 m ³	
Inlet (mm)	6 x 110mm	6 x 110mm	1x 63mm
Outlet (mm)	2 x 110mm	2 x 110mm	
Internal flushing pump	SS 5 bar/750 watt 220V	SS 5 bar/750 watt 220V	
Industrial motor	130Nm/60 watt 220V	130Nm/60 watt 220V	
Built-in UVC unit	80 watt H-O	80 watt H-O	
Air supply	2 x 50 x 300mm	2 x 50 x 300mm	
Control box	including	including	
Item no.	WMC22CDG	WMC22CDP	WMC22CDT

Spare parts & biological filter media

Product	Item no.
Replacement UV-C HO 80 W lamp for SS housing	RLM0021
HO 80 W quartz sleeve	QS0006
Inox Excellent 80 watt electrical unit	EPM0003EX
Sieve panel 4 x 1000 x 400mm Ø 65	ZS00007EX
3m ² Japanese mat 50mm open surface area 645 2m ² m ³ (optional)	3001484
Hel-X 13x12mm 955m ² m ³ 2 bags of 100 liter (optional)	3001139



Discover the
complete Excellent
series

Combi Drum 60/80 XL

Refined and optimized

Through the acquisition and practical application of knowledge, a new and unique filter series has been developed. Existing technologies have been further refined and optimized. We proudly present our high-quality filter: the Filtreau Excellent series. This series can be easily expanded with an optional UV-C HO 80 W unit, allowing for a fully configurable system that contributes to a clear and clean pond. It supports the breakdown of ammonia, nitrite and nitrate. As the Filtreau Excellent filters are entirely developed in-house, every aspect has been carefully considered.

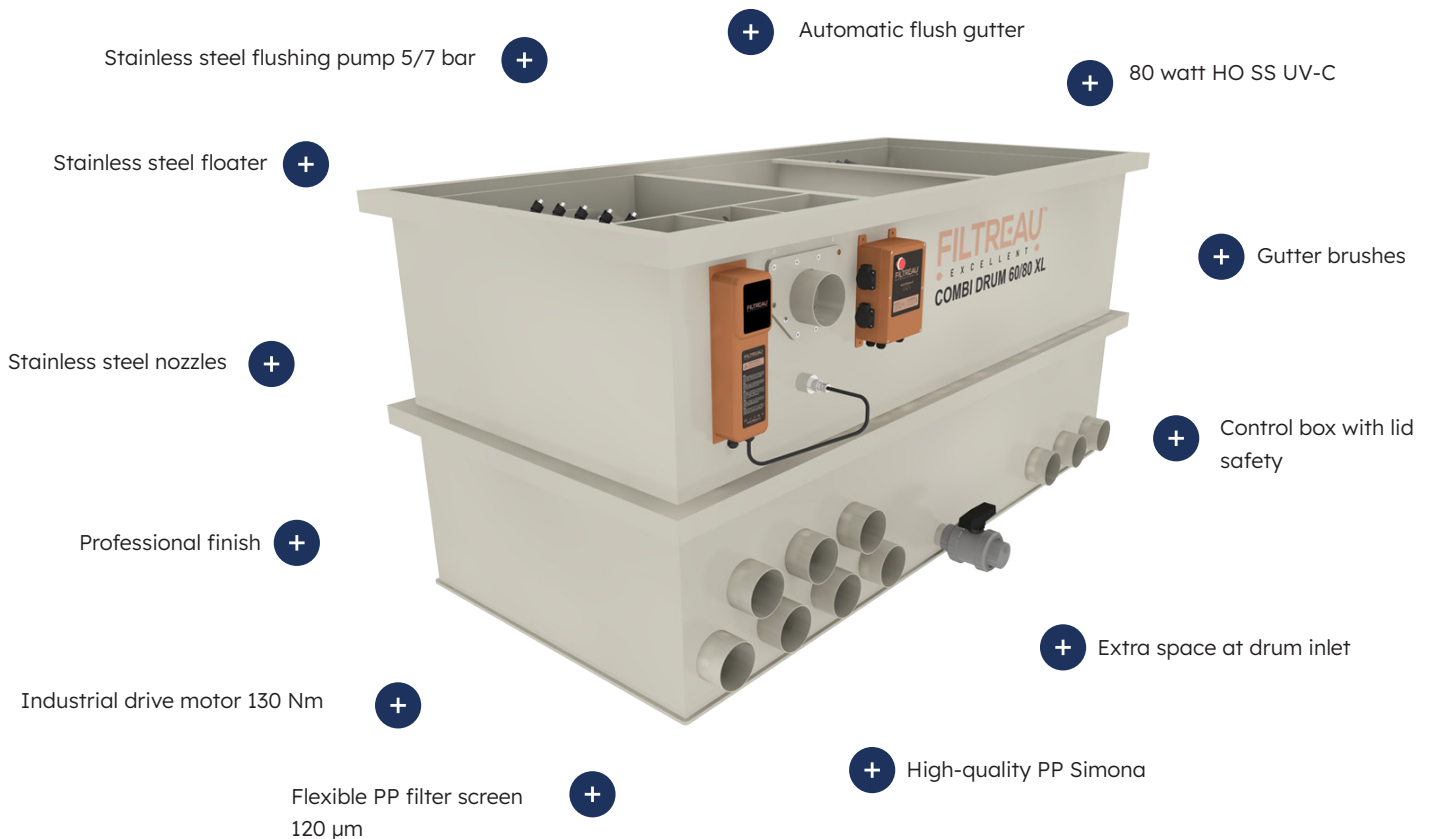

Drum filter

A pre-filter is a drum filter that efficiently removes very fine debris (120 µm) from the water. The water enters the drum filter either pump-fed or gravity-fed, where contaminants are separated from the water. The water flows from the inside of the drum through the filter screen to the outside of the unit. The debris remains on the sieve panel (PP), which is mounted on the drum. The sieve panel (PP) is fitted with a fine stainless steel mesh (120 µm)

The debris is rinsed off the sieve panel (PP) by means of stainless steel nozzles and collected in the gutter. The gutter flushing system ensures that the contaminants are discharged towards the outlet. The cleaning frequency depends on the level of contamination of the pond water.





EXCELLENT LINE

The control box of the Excellent series is standard equipped with:

Automatic cleaning: floor switch. **Manual operation:** turn button / rinse. **Drum flushing time:** 10 sec. **Flushing level (gravity-fed):** adjustable. **Flushing level (pump-fed):** not adjustable. **Power outlets:** flushing pump, pond pump, drum drive motor and UVC HO 40 W or 80 W (stainless steel). **Dry-run protection deactivation:** 30 sec (UVC lamp). **Flush protection:** after 5 minutes of continuous flushing, the control box switches off, manual reset required. **Magnetic safety switch:** opening the lid switches off the control box.

Technical specifications

			
Product	COMBI DRUM 60/80 XL GRAVITY	COMBI DRUM 60/80 XL PUMP	TRICKLE FOR COMBI DRUM 60/80 XL
Length x width x height	2100 x 1117mm x 1005mm	2100 x 1117 x 1005mm	1250 x 320 x 805mm
Drum	Ø 650 x 400mm	Ø 650 x 400mm	Distribution box
Mesh size screen (PP) with stainless steel (SS) mesh	120 µm	120 µm	
Max. Flow	80 m ³	55 m ³	30 m ³
Max. pond volume	160 m ³	110 m ³	
Max. pond volume with koi	80 m ³	55 m ³	
Inlet (mm)	7 x 110mm	7 x 110mm	1x 63mm
Outlet (mm)	3 x 110mm	3 x 110mm	
Internal flushing pump	SS 5 bar/750 watt 220V	SS 5 bar/750 watt 220V	
Industrial motor	130Nm/60 watt 220V	130Nm/60 watt 220V	
Built-in UVC unit	80 watt H-O	80 watt H-O	
Air supply	4 x 50 x 300mm	4 x 50 x 300mm	
Control box	including	including	
Item no.	WMC23CDG	WMC23CDP	WMC23CDT

Spare parts & biological filter media

Product	Item no.
Replacement UV-C HO 80 W lamp for SS housing	RLM0021
HO 80 W quartz sleeve	QS0006
Inox Excellent 80 watt electrical unit	EPM0003EX
Sieve panel 2 x 1000 x 400mm Ø 65	ZS00007EX
4,5m ² Japanese mat 50mm open surface area 645 2m ² m ³ (optional)	3001484
Hel-X 13x12mm 955m ² m ³ 2 bags of 100 liter (optional)	3001139



Discover the
complete Excellent
series

Combi Drum 80/100 XXL

Refined and optimized

Through the acquisition and practical application of knowledge, a new and unique filter series has been developed. Existing technologies have been further refined and optimized. We proudly present our high-quality filter: the Filtreau Excellent series. This series can be easily expanded with an optional UV-C HO 80 W unit, allowing for a fully configurable system that contributes to a clear and clean pond. It supports the breakdown of ammonia, nitrite and nitrate. As the Filtreau Excellent filters are entirely developed in-house, every aspect has been carefully considered.

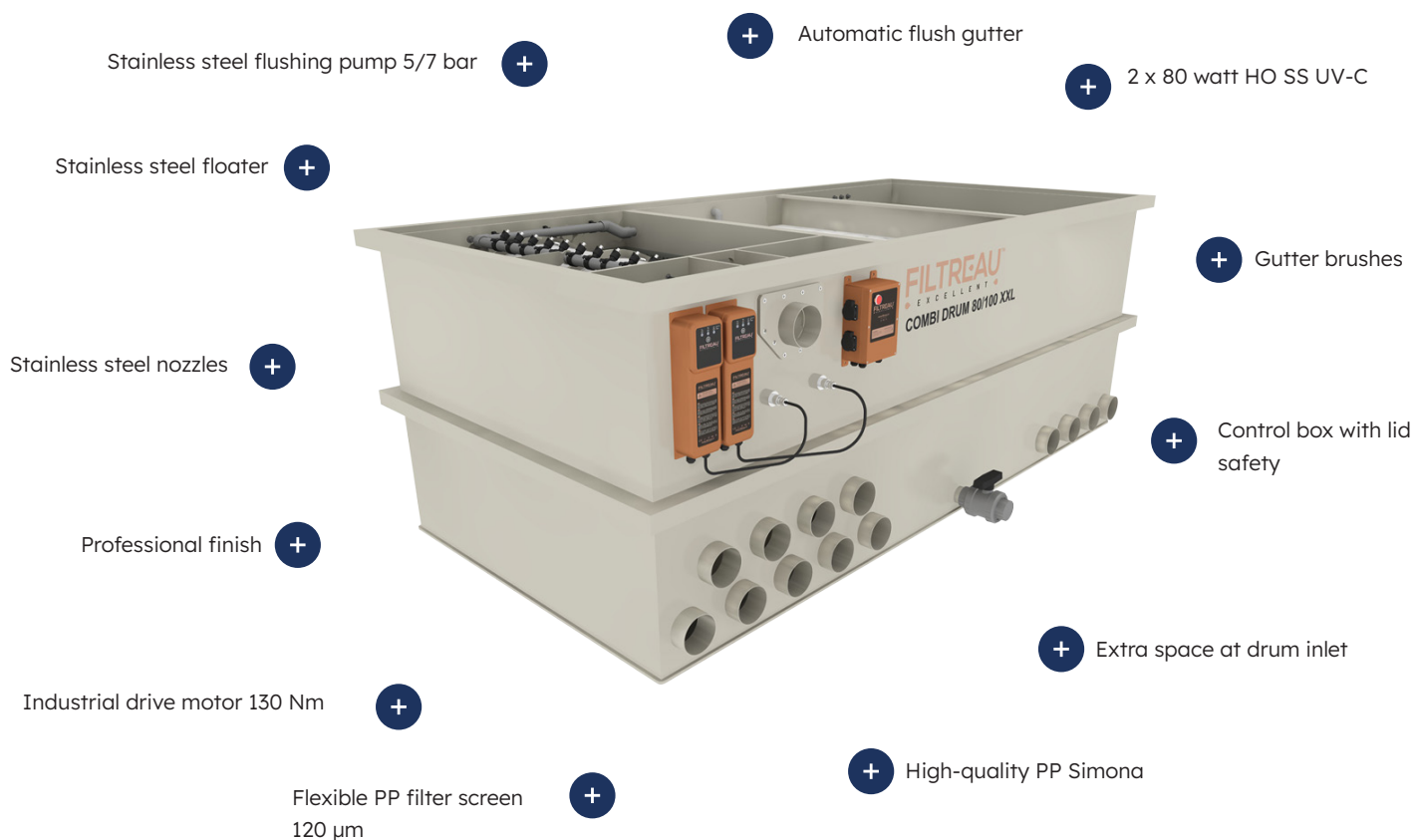

Drum filter

A pre-filter is a drum filter that efficiently removes very fine debris (120 µm) from the water. The water enters the drum filter either pump-fed or gravity-fed, where contaminants are separated from the water. The water flows from the inside of the drum through the filter screen to the outside of the unit. The debris remains on the sieve panel (PP), which is mounted on the drum. The sieve panel (PP) is fitted with a fine stainless steel mesh (120 µm)

The debris is rinsed off the sieve panel (PP) by means of stainless steel nozzles and collected in the gutter. The gutter flushing system ensures that the contaminants are discharged towards the outlet. The cleaning frequency depends on the level of contamination of the pond water.



EXCELLENT LINE

The control box of the Excellent series is standard equipped with:

Automatic cleaning: floor switch. **Manual operation:** turn button / rinse. **Drum flushing time:** 10 sec. **Flushing level (gravity-fed):** adjustable. **Flushing level (pump-fed):** not adjustable. **Power outlets:** flushing pump, pond pump, drum drive motor and UVC HO 40 W or 80 W (stainless steel). **Dry-run protection deactivation:** 30 sec (UVC lamp). **Flush protection:** after 5 minutes of continuous flushing, the control box switches off, manual reset required. **Magnetic safety switch:** opening the lid switches off the control box.

Technical specifications



Product	COMBI DRUM 80/100 XXL GRAVITY	COMBI DRUM 80/100 XXL PUMP	TRICKLE FOR COMBI DRUM 80/100 XXL
Length x width x height	2760 x 1515 x 1005mm	2760 x 1515 x 1005mm	1700 x 320mm x 805mm
Drum	Ø 650 x 800mm	Ø 650 x 800mm	Distribution box
Mesh size screen (PP) with stainless steel (SS) mesh	120 µm	120 µm	
Max. Flow	100 m ³	70 m ³	40 m ³
Max. pond volume	200 m ³	140 m ³	
Max. pond volume with koi	100 m ³	70 m ³	
Inlet (mm)	9 x 110mm	9 x 110mm	1x 110mm
Outlet (mm)	4 x 110mm	4 x 110mm	
Internal flushing pump	SS 5 bar/750 watt 220V	SS 5 bar/750 watt 220V	
Industrial motor	130Nm/60 watt 220V	130Nm/60 watt 220V	
Built-in UVC unit	2 x 80 watt H-O	2 x 80 watt H-O	
Air supply	8 x 50 x 300mm	8 x 50 x 300mm	
Control box	including	including	
Item no.	WMC24CDG	WMC24CDP	WMC24CDT

Spare parts & biological filter media

Product	Item no.
Replacement UV-C HO 80 W lamp for SS housing	RLM0021
HO 80 W quartz sleeve	QS0006
Inox Excellent 80 watt electrical unit	EPM0003EX
Sieve panel 4 x 1000 x 400mm Ø 65	ZS00007EX
10m ² Japanse mat 50mm open surface area 645 2m ² m ³ (optional)	3001484
Hel-X 13x12mm 955m ² m ³ 5 bags of 100 liter (optional)	3001139



Discover the
complete Excellent
series

Combi Drum 10/15 S LOW In Line

Refined and optimized

Through the acquisition and practical application of knowledge, a new and unique filter series has been developed. Existing technologies have been further refined and optimized. We proudly present our high-quality filter: the Filtreau Excellent series. This series can be easily expanded with an optional UV-C HO 80 W unit, allowing for a fully configurable system that contributes to a clear and clean pond. It supports the breakdown of ammonia, nitrite and nitrate. As the Filtreau Excellent filters are entirely developed in-house, every aspect has been carefully considered.

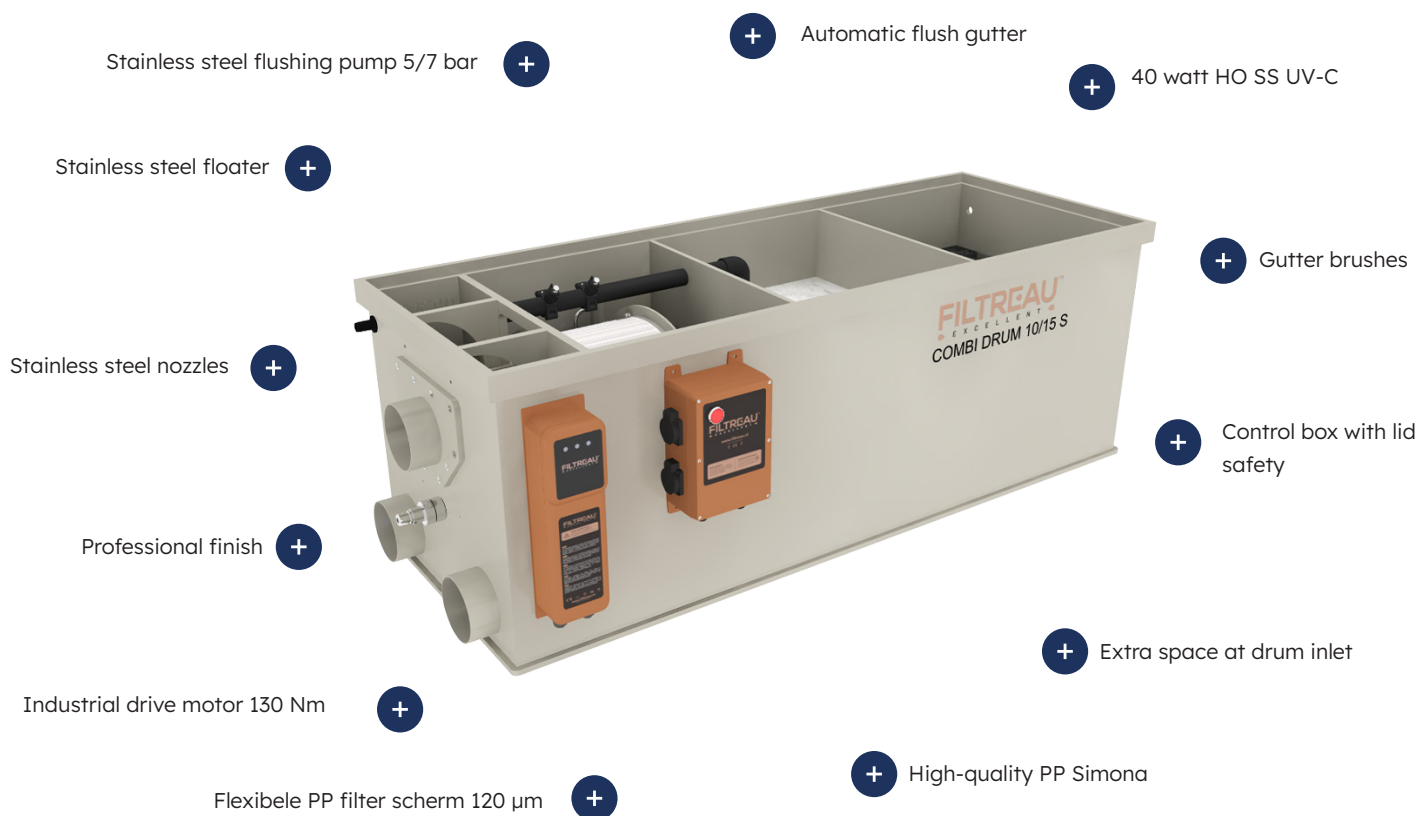

Drum filter

A pre-filter is a drum filter that efficiently removes very fine debris (120 µm) from the water. The water enters the drum filter either pump-fed or gravity-fed, where contaminants are separated from the water. The water flows from the inside of the drum through the filter screen to the outside of the unit. The debris remains on the sieve panel (PP), which is mounted on the drum. The sieve panel (PP) is fitted with a fine stainless steel mesh (120 µm)

The debris is rinsed off the sieve panel (PP) by means of stainless steel nozzles and collected in the gutter. The gutter flushing system ensures that the contaminants are discharged towards the outlet. The cleaning frequency depends on the level of contamination of the pond water.



EXCELLENT LINE

The control box of the Excellent series is standard equipped with:

Automatic cleaning: floor switch. **Manual operation:** turn button / rinse. **Drum flushing time:** 10 sec. **Flushing level (gravity-fed):** adjustable. **Flushing level (pump-fed):** not adjustable. **Power outlets:** flushing pump, pond pump, drum drive motor and UVC HO 40 W or 80 W (stainless steel). **Dry-run protection deactivation:** 30 sec (UVC lamp). **Flush protection:** after 5 minutes of continuous flushing, the control box switches off, manual reset required. **Magnetic safety switch:** opening the lid switches off the control box.

Technical specifications

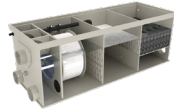

Product	COMBI DRUM 10/15 S LOW In Line GRAVITY
Length x width x height	1575 x 530 x 498mm
Drum	Ø 400 x 200mm
Mesh size screen (PP) with stainless steel (SS) mesh	120 µm
Max. Flow	15 m ³
Max. pond volume	25 m ³
Max. pond volume with koi	15 m ³
Inlet (mm)	2 x 110mm
Outlet (mm)	1 x 110mm
Internal flushing pump	SS 4 bar / 750watt 220 volt
Industrial motor	130Nm /60 watt 220volt
Built-in UVC unit	40 watt H-O
Air supply	2 x 40 x 300mm
Control box	including
Item no.	WMC29ILG

Spare parts & biological filter media

Product	Item no.
Replacement lamp UV-C HO 40 watt	RLM0020
Quartz glass HO 40 watt	QS0005
Electrical unit for Inox Excellent 40 watt	EPM0001EX
Sieve panel 1 x 1140 x 400mm Ø 40	ZS0005EX
1 m ² Japanese mat, 50 mm, open surface area 645 m ² /m ³	3001484
Hel-X 13x12mm 955m ² m ³ 100 liter (optional)	3001139



**Discover the
complete Excellent
series**

Combi Drum 25/30 LOW In Line

Refined and optimized

Through the acquisition and practical application of knowledge, a new and unique filter series has been developed. Existing technologies have been further refined and optimized. We proudly present our high-quality filter: the Filtreau Excellent series. This series can be easily expanded with an optional UV-C HO 80 W unit, allowing for a fully configurable system that contributes to a clear and clean pond. It supports the breakdown of ammonia, nitrite and nitrate. As the Filtreau Excellent filters are entirely developed in-house, every aspect has been carefully considered.

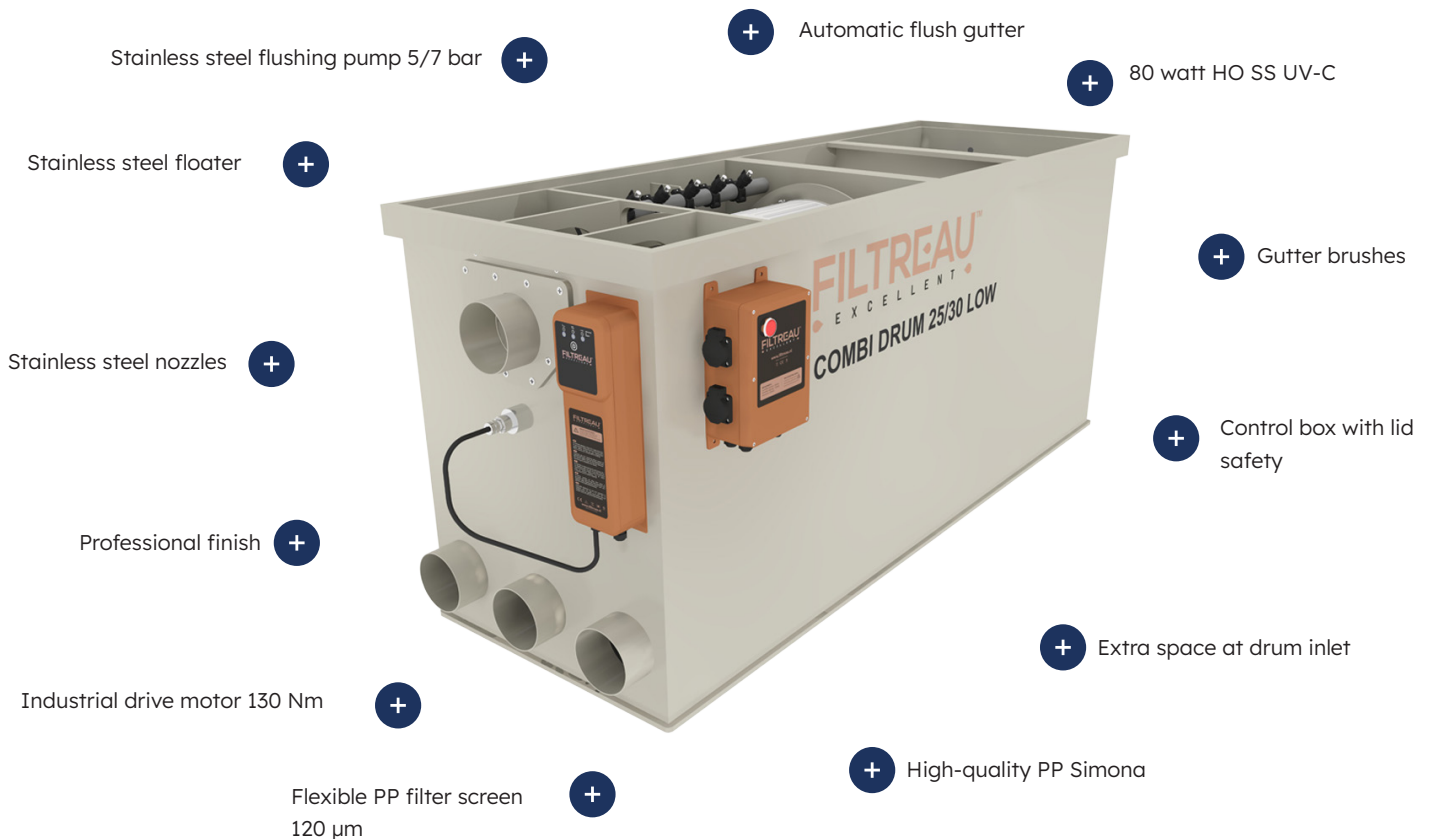

Drum filter

A pre-filter is a drum filter that efficiently removes very fine debris (120 µm) from the water. The water enters the drum filter either pump-fed or gravity-fed, where contaminants are separated from the water. The water flows from the inside of the drum through the filter screen to the outside of the unit. The debris remains on the sieve panel (PP), which is mounted on the drum. The sieve panel (PP) is fitted with a fine stainless steel mesh (120 µm)

The debris is rinsed off the sieve panel (PP) by means of stainless steel nozzles and collected in the gutter. The gutter flushing system ensures that the contaminants are discharged towards the outlet. The cleaning frequency depends on the level of contamination of the pond water.



EXCELLENT LINE

The control box of the Excellent series is standard equipped with:

Automatic cleaning: floor switch. **Manual operation:** turn button / rinse. **Drum flushing time:** 10 sec. **Flushing level (gravity-fed):** adjustable. **Flushing level (pump-fed):** not adjustable. **Power outlets:** flushing pump, pond pump, drum drive motor and UVC HO 40 W or 80 W (stainless steel). **Dry-run protection deactivation:** 30 sec (UVC lamp). **Flush protection:** after 5 minutes of continuous flushing, the control box switches off, manual reset required. **Magnetic safety switch:** opening the lid switches off the control box.

Technical specifications



Product	COMBI DRUM 25/30 LOW In Line GRAVITY	COMBI DRUM 25/30 LOW In Line PUMP	TRICKLE FOR COMBI DRUM 25/30 LOW In Line
Length x width x height	1935 x 590 x 750mm	1935 x 590 x 750mm	860 x 320 x 822mm
Drum	Ø 400 x 400mm	Ø 400 x 400mm	Distribution box
Mesh size screen (PP) with stainless steel (SS) mesh	120 µm	120 µm	
Max. Flow	30 m ³	20 m ³	20 m ³
Max. pond volume	50 m ³	40 m ³	
Max. pond volume with koi	30 m ³	20 m ³	
Inlet (mm)	3 x 110mm	3 x 110mm	1x 63mm
Outlet (mm)	2 x 110mm	2 x 110mm	
Internal flushing pump	SS 5 bar/750 watt 220V	SS 5 bar/750 watt 220V	
Industrial motor	130Nm/60 watt 220V	130Nm/60 watt 220V	
Built-in UVC unit	80 watt H-O	80 watt H-O	
Air supply	2 x 50 x 300mm	2 x 50 x 300mm	
Control box	including	including	
Item no.	WMC30ILG	WMC30ILP	WMC30ILT

Spare parts & biological filter media

Product	Item no.
Replacement UV-C HO 80 W lamp for SS housing	RLM0021
HO 80 W quartz sleeve	QS0006
Inox Excellent 80 watt electrical unit	EPM0003EX
Sieve panel 1 x 1140 x 400mm Ø 40	ZS0005EX
2m ² Japanese mat 50mm open surface area 645 2m ² m ³ (optional)	3001484
Hel-X 13x12mm 955m ² m ³ 100 liter (optional)	3001139



Discover the complete Excellent series

Combi Drum 30/40 LOW In Line

Refined and optimized

Through the acquisition and practical application of knowledge, a new and unique filter series has been developed. Existing technologies have been further refined and optimized. We proudly present our high-quality filter: the Filtreau Excellent series. This series can be easily expanded with an optional UV-C HO 80 W unit, allowing for a fully configurable system that contributes to a clear and clean pond. It supports the breakdown of ammonia, nitrite and nitrate. As the Filtreau Excellent filters are entirely developed in-house, every aspect has been carefully considered.

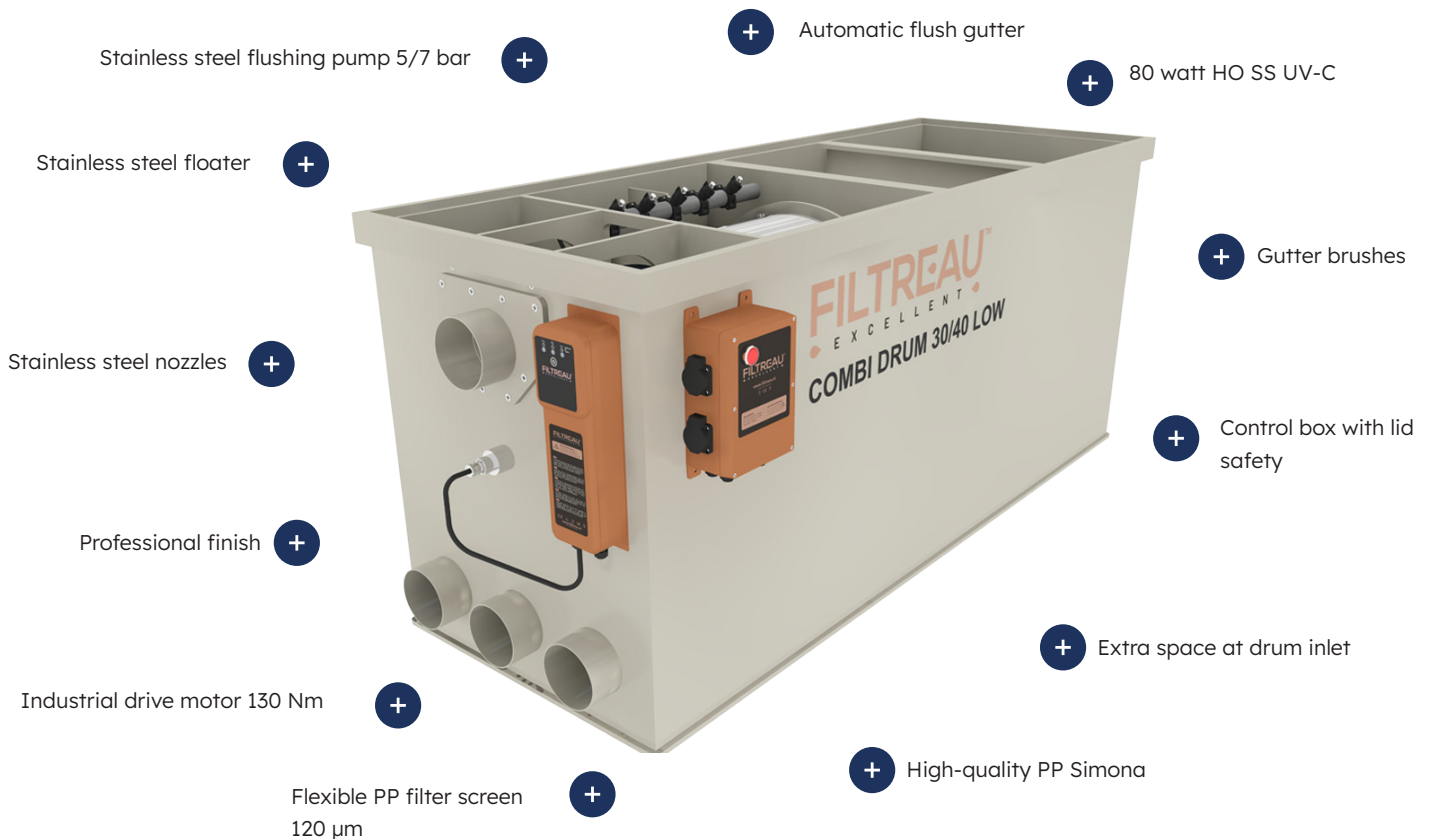

Drum filter

A pre-filter is a drum filter that efficiently removes very fine debris (120 µm) from the water. The water enters the drum filter either pump-fed or gravity-fed, where contaminants are separated from the water. The water flows from the inside of the drum through the filter screen to the outside of the unit. The debris remains on the sieve panel (PP), which is mounted on the drum. The sieve panel (PP) is fitted with a fine stainless steel mesh (120 µm)

The debris is rinsed off the sieve panel (PP) by means of stainless steel nozzles and collected in the gutter. The gutter flushing system ensures that the contaminants are discharged towards the outlet. The cleaning frequency depends on the level of contamination of the pond water.



EXCELLENT LINE

The control box of the Excellent series is standard equipped with:

Automatic cleaning: floor switch. **Manual operation:** turn button / rinse. **Drum flushing time:** 10 sec. **Flushing level (gravity-fed):** adjustable. **Flushing level (pump-fed):** not adjustable. **Power outlets:** flushing pump, pond pump, drum drive motor and UVC HO 40 W or 80 W (stainless steel). **Dry-run protection deactivation:** 30 sec (UVC lamp). **Flush protection:** after 5 minutes of continuous flushing, the control box switches off, manual reset required. **Magnetic safety switch:** opening the lid switches off the control box.

Technical specifications



Product	COMBI DRUM 30/40 LOW In Line GRAVITY	COMBI DRUM 30/40 LOW In Line PUMP	TRICKLE FOR COMBI DRUM 30/40 LOW In Line
Length x width x height	1935 x 640 x 750mm	1935 x 640 x 750mm	860 x 320 x 822mm
Drum	Ø 500 x 400mm	Ø 500 x 400mm	Distribution box
Mesh size screen (PP) with stainless steel (SS) mesh	120 µm	120 µm	
Max. Flow	45 m ³	30 m ³	20 m ³
Max. pond volume	90 m ³	60 m ³	
Max. pond volume with koi	45 m ³	30 m ³	
Inlet (mm)	3 x 110mm	3 x 110mm	1x 63mm
Outlet (mm)	2 x 110mm	2 x 110mm	
Internal flushing pump	SS 5 bar/750 watt 220V	SS 5 bar/750 watt 220V	
Industrial motor	130Nm/60 watt 220V	130Nm/60 watt 220V	
Built-in UVC unit	80 watt H-O	80 watt H-O	
Air supply	2 x 50 x 300mm	2 x 50 x 300mm	
Control box	including	including	
Item no.	WMC31ILG	WMC31ILP	WMC31ILT

Spare parts & biological filter media

Product	Item no.
Replacement UV-C HO 80 W lamp for SS housing	RLM0021
HO 80 W quartz sleeve	QS0006
Inox Excellent 80 watt electrical unit	EPM0003EX
Sieve panel 2 x 750 x 400mm Ø 50	ZS00006EX
2m ² Japanese mat 50mm open surface area 645 2m ² m ³ (optional)	3001484
Hel-X 13x12mm 955m ² m ³ 100 liter (optional)	3001139



Discover the complete Excellent series

Combi Drum 30/45 L In Line

Refined and optimized

Through the acquisition and practical application of knowledge, a new and unique filter series has been developed. Existing technologies have been further refined and optimized. We proudly present our high-quality filter: the Filtreau Excellent series. This series can be easily expanded with an optional UV-C HO 80 W unit, allowing for a fully configurable system that contributes to a clear and clean pond. It supports the breakdown of ammonia, nitrite and nitrate. As the Filtreau Excellent filters are entirely developed in-house, every aspect has been carefully considered.

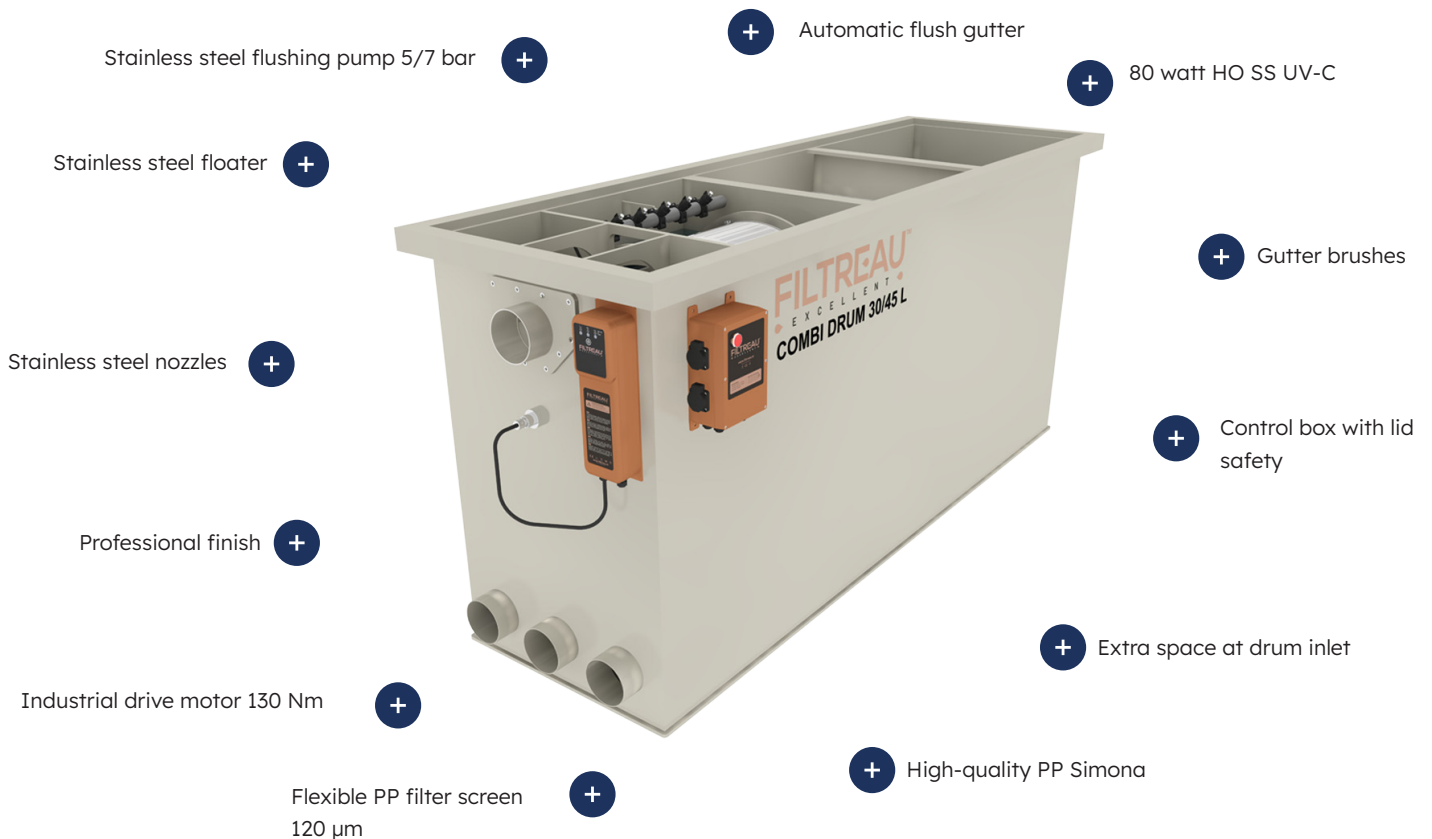

Drum filter

A pre-filter is a drum filter that efficiently removes very fine debris (120 µm) from the water. The water enters the drum filter either pump-fed or gravity-fed, where contaminants are separated from the water. The water flows from the inside of the drum through the filter screen to the outside of the unit. The debris remains on the sieve panel (PP), which is mounted on the drum. The sieve panel (PP) is fitted with a fine stainless steel mesh (120 µm)

The debris is rinsed off the sieve panel (PP) by means of stainless steel nozzles and collected in the gutter. The gutter flushing system ensures that the contaminants are discharged towards the outlet. The cleaning frequency depends on the level of contamination of the pond water.

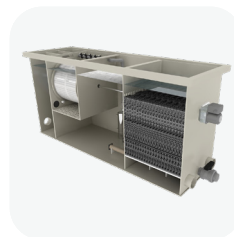



EXCELLENT LINE

The control box of the Excellent series is standard equipped with:

Automatic cleaning: floor switch. **Manual operation:** turn button / rinse. **Drum flushing time:** 10 sec. **Flushing level (gravity-fed):** adjustable. **Flushing level (pump-fed):** not adjustable. **Power outlets:** flushing pump, pond pump, drum drive motor and UVC HO 40 W or 80 W (stainless steel). **Dry-run protection deactivation:** 30 sec (UVC lamp). **Flush protection:** after 5 minutes of continuous flushing, the control box switches off, manual reset required. **Magnetic safety switch:** opening the lid switches off the control box.

Technical specifications

			
Product	COMBI DRUM 30/45 L In Line GRAVITY	COMBI DRUM 30/45 L In Line PUMP	TRICKLE FOR COMBI DRUM 30/45 L In Line
Length x width x height	2254 x 700 x 1005mm	2254 x 700 x 1005mm	1180 x 320mm x 805mm
Drum	Ø 500 x 400mm	Ø 500 x 400mm	Distribution box
Mesh size screen (PP) with stainless steel (SS) mesh	120 µm	120 µm	
Max. Flow	50 m ³	35 m ³	30 m ³
Max. pond volume	100 m ³	70 m ³	
Max. pond volume with koi	50 m ³	35 m ³	
Inlet (mm)	3 x 110mm	3 x 110mm	1x 110mm
Outlet (mm)	2 x 110mm	2 x 110mm	
Internal flushing pump	SS 5 bar/600 watt 220/230V	SS 5 bar/600 watt 220/230V	
Industrial motor	130Nm/60 watt 220/230V	130Nm/60 watt 220/230V	
Built-in UVC unit	80 watt H-O	80 watt H-O	
Air supply	4 x 50 x 300mm	4 x 50 x 300mm	
Control box	including	including	
Item no.	WMC32ILG	WMC32ILP	WMC32ILT

Spare parts & biological filter media

Product	Item no.
Replacement UV-C HO 80 W lamp for SS housing	RLM0021
HO 80 W quartz sleeve	QS0006
Inox Excellent 80 watt electrical unit	EPM0003EX
Sieve panel 2 x 750 x 400mm Ø 50	ZS00006EX
4m ² Japanese mat 50mm open surface area 645 2m ² m ³ (optional)	3001484
Hel-X 13x12mm 955m ² m ³ 2 bags of 100 liter (optional)	3001139



Discover the
complete Excellent
series

Combi Drum 50/65 XL In Line

Combi drum inline filter

The operation of a combi drum inline filter is exactly the same as that of a combi drum filter. The advantage of a combi drum inline filter is that all connections are located on one end of the system. This simplifies and optimizes the installation.

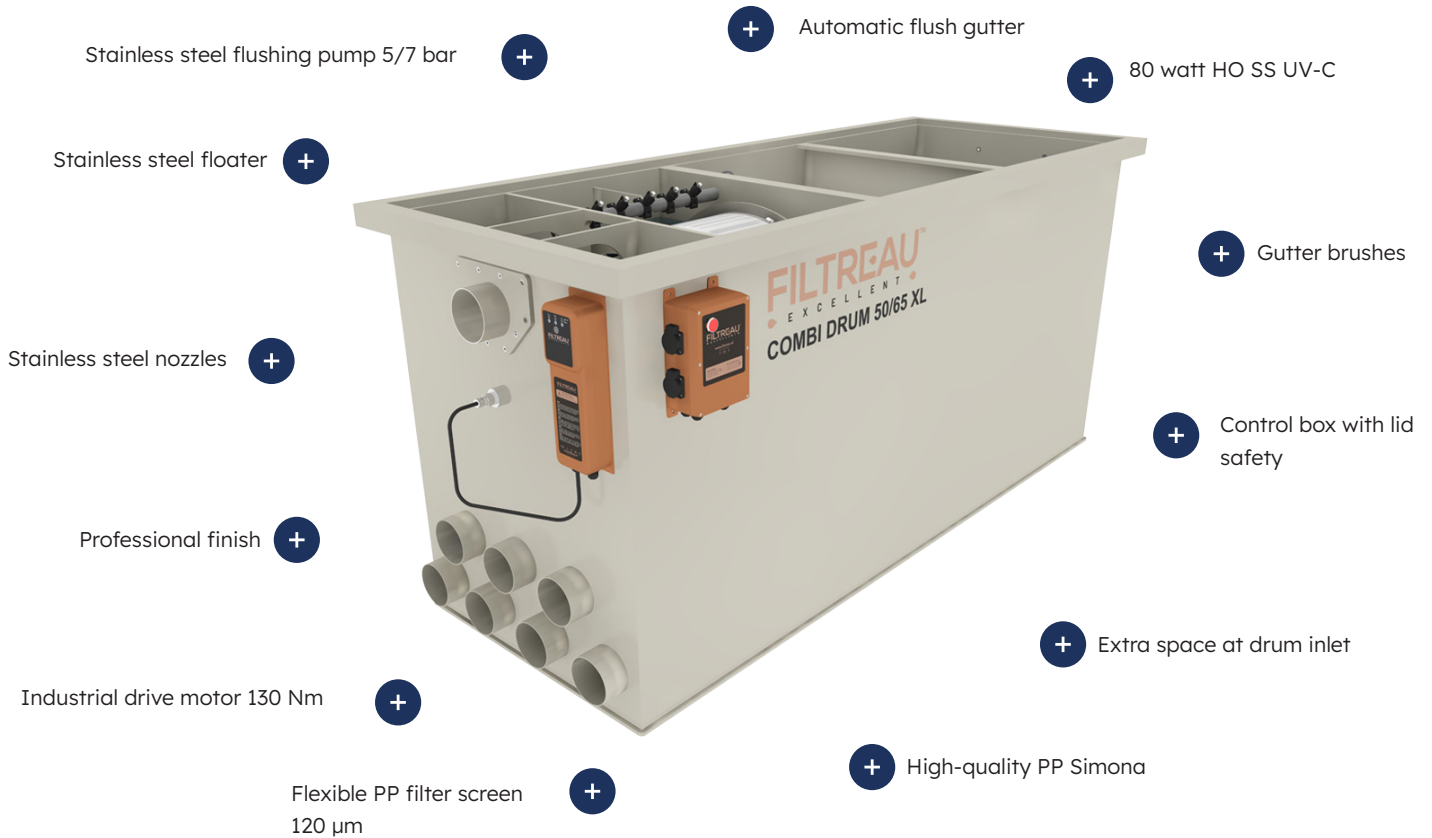

Our combi drum inline filters are equipped with an innovative drum filtration system which, combined with a moving bed filter, ensures optimal water flow and filtration. First, the contaminated pond water enters the collection chamber. The second chamber provides mechanical filtration and houses the drum filter.

In the third chamber, an air disc or air stone is installed at the bottom. This must be connected to an external air pump to create movement within the chamber. For optimal performance, this chamber should be filled to a maximum of 70% of its volume with moving bed media such as Hel-X.

After several weeks, beneficial bacteria will attach to the Hel-X, enabling biological filtration of the water. As the media is continuously in motion, no debris can accumulate. This keeps the media clean and results in little to no maintenance.





EXCELLENT LINE

The control box of the Excellent series is standard equipped with:

Automatic cleaning: floor switch. **Manual operation:** turn button / rinse. **Drum flushing time:** 10 sec. **Flushing level (gravity-fed):** adjustable. **Flushing level (pump-fed):** not adjustable. **Power outlets:** flushing pump, pond pump, drum drive motor and UVC HO 40 W or 80 W (stainless steel). **Dry-run protection deactivation:** 30 sec (UVC lamp). **Flush protection:** after 5 minutes of continuous flushing, the control box switches off, manual reset required. **Magnetic safety switch:** opening the lid switches off the control box.

Technical specifications

			
Product	COMBI DRUM 50/65 XL In Line GRAVITY	COMBI DRUM 50/65 XL In Line PUMP	TRICKLE FOR COMBI DRUM 50/65 XL In Line
Length x width x height	2254 x 850 x 1005mm	2254 x 850 x 1005mm	1180 x 320 x 808mm
Drum	Ø 650 x 400mm	Ø 650 x 400mm	Distribution box
Mesh size screen (PP) with stainless steel (SS) mesh	120 µm	120 µm	
Max. Flow	65 m ³	45 m ³	30 m ³
Max. pond volume	130 m ³	90 m ³	
Max. pond volume with koi	65 m ³	45 m ³	
Inlet (mm)	7 x 110mm	7 x 110mm	1x 110mm
Outlet (mm)	3 x 110mm	3 x 110mm	
Internal flushing pump	SS 5 bar/750 watt 220V	SS 5 bar/750 watt 220V	
Industrial motor	130Nm/60 watt 220V	130Nm/60 watt 220V	
Built-in UVC unit	80 watt H-O	80 watt H-O	
Air supply	4 x 50 x 300mm	4 x 50 x 300mm	
Control box	including	including	
Item no.	WMC33ILG	WMC33ILP	WMC33ILT

Spare parts & biological filter media

Product	Item no.
Replacement UV-C HO 80 W lamp for SS housing	RLM0021
HO 80 W quartz sleeve	QS0006
Inox Excellent 80 watt electrical unit	EPM0003EX
Sieve panel 2 x 1000 x 400mm Ø 65	ZS00007EX
4m ² Japanese mat 50mm open surface area 645 2m ² m ³ (optional)	3001484
Hel-X 13x12mm 955m ² m ³ 2 x bags of 100 liter (optional)	3001139



Discover the complete Excellent series

Combi Drum 80/100 XXL In Line

Combi drum inline filter

The operation of a combi drum inline filter is exactly the same as that of a combi drum filter. The advantage of a combi drum inline filter is that all connections are located on one end of the system. This simplifies and optimizes the installation.

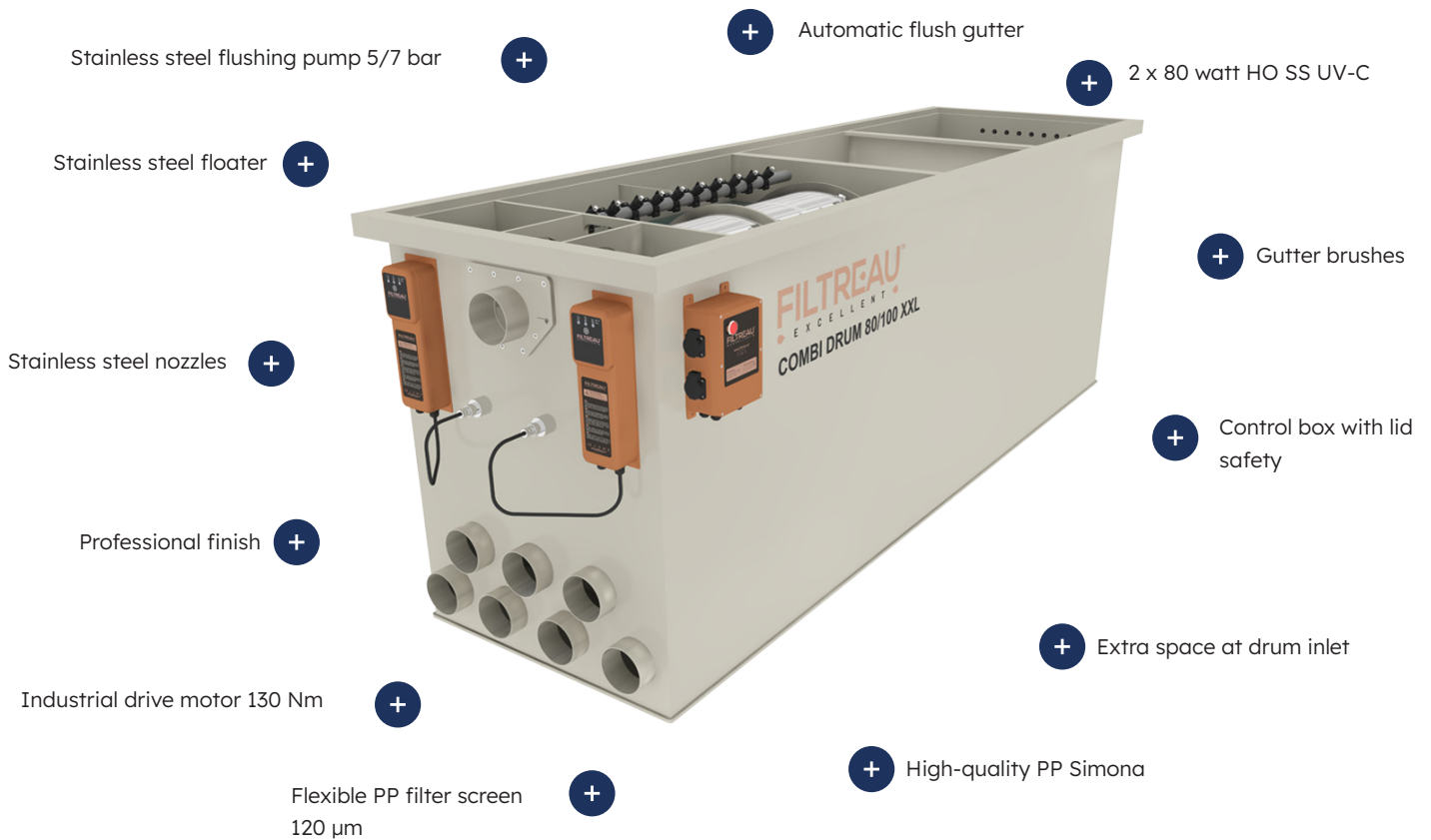

Our combi drum inline filters are equipped with an innovative drum filtration system which, combined with a moving bed filter, ensures optimal water flow and filtration. First, the contaminated pond water enters the collection chamber. The second chamber provides mechanical filtration and houses the drum filter.

In the third chamber, an air disc or air stone is installed at the bottom. This must be connected to an external air pump to create movement within the chamber. For optimal performance, this chamber should be filled to a maximum of 70% of its volume with moving bed media such as Hel-X.

After several weeks, beneficial bacteria will attach to the Hel-X, enabling biological filtration of the water. As the media is continuously in motion, no debris can accumulate. This keeps the media clean and results in little to no maintenance.





EXCELLENT LINE

The control box of the Excellent series is standard equipped with:

Automatic cleaning: floor switch. **Manual operation:** turn button / rinse. **Drum flushing time:** 10 sec. **Flushing level (gravity-fed):** adjustable. **Flushing level (pump-fed):** not adjustable. **Power outlets:** flushing pump, pond pump, drum drive motor and UVC HO 40 W or 80 W (stainless steel). **Dry-run protection deactivation:** 30 sec (UVC lamp). **Flush protection:** after 5 minutes of continuous flushing, the control box switches off, manual reset required. **Magnetic safety switch:** opening the lid switches off the control box.

Technical specifications

			
Product	COMBI DRUM 80/100 XXL In Line GRAVITY	COMBI DRUM 80/100 XXL In Line PUMP	TRICKLE FOR COMBI DRUM 80/100 XXL In Line
Length x width x height	2900 x 850 x 1005mm	2900 x 850 x 1005mm	1400 x 320 x 808mm
Drum	Ø 650 x 800mm	Ø 650 x 800mm	Distribution box
Mesh size screen (PP) with stainless steel (SS) mesh	120 µm	120 µm	
Max. Flow	100 m ³	70 m ³	30 m ³
Max. pond volume	200 m ³	140 m ³	
Max. pond volume with koi	100 m ³	70 m ³	
Inlet (mm)	7 x 110mm	7 x 110mm	1x 110mm
Outlet (mm)	3 x 110mm	3 x 110mm	
Internal flushing pump	SS 5 bar/750 watt 220V	SS 5 bar/750 watt 220V	
Industrial motor	130Nm/60 watt 220V	130Nm/60 watt 220V	
Built-in UVC unit	2 x 80 watt H-O	2 x 80 watt H-O	
Air supply	4 x 50 x 300mm	4 x 50 x 300mm	
Control box	including	including	
Item no.	WMC34ILG	WMC34ILP	WMC34ILT

Spare parts & biological filter media

Product	Item no.
Replacement UV-C HO 80 W lamp for SS housing	RLM0021
HO 80 W quartz sleeve	QS0006
Inox Excellent 80 watt electrical unit	EPM0003EX
Sieve panel 4 x 1000 x 400mm Ø 65	ZS00007EX
1,8m ² Japanese mat 50mm open surface area 645 2m ² m ³ (optional)	3001484
Hel-X 13x12mm 955m ² m ³ 100 liter (optional)	3001139



Discover the complete Excellent series

Combi Drum 30/50 ROTATE

Refined and optimized

Through the acquisition and practical application of knowledge, a new and unique filter series has been developed. Existing technologies have been further refined and optimized. We proudly present our high-quality filter: the Filtreau Excellent series. This series can be easily expanded with an optional UV-C HO 80 W unit, allowing for a fully configurable system that contributes to a clear and clean pond. It supports the breakdown of ammonia, nitrite and nitrate. As the Filtreau Excellent filters are entirely developed in-house, every aspect has been carefully considered.



Combi drum rotate

The operation of a Combi Drum Rotate is exactly the same as that of a combi drum filter or inline filter. The Combi Drum Rotate features a rotating biological chamber filled with Hel-X, which does not require any additional pump head.

Nitrifying bacteria attach to the Hel-X, enabling the breakdown of ammonia and nitrite. In addition, the rotating biological system provides extra oxygenation of the pond.





EXCELLENT LINE

The control box of the Excellent series is standard equipped with:

Automatic cleaning: floor switch. **Manual operation:** turn button / rinse. **Drum flushing time:** 10 sec. **Flushing level (gravity-fed):** adjustable. **Flushing level (pump-fed):** not adjustable. **Power outlets:** flushing pump, pond pump, drum drive motor and UVC HO 40 W or 80 W (stainless steel). **Dry-run protection deactivation:** 30 sec (UVC lamp). **Flush protection:** after 5 minutes of continuous flushing, the control box switches off, manual reset required. **Magnetic safety switch:** opening the lid switches off the control box.

Technical specifications

			
Product	COMBI DRUM 30/50 ROTATE GRAVITY	COMBI DRUM 30/50 ROTATE PUMP	TRICKLE FOR COMBI DRUM 30/50 ROTATE
Length x width x height	1773 x 1163 x 1005mm	1773 x 1163 x 1005mm	1060 x 320 x 808mm
Drum	Ø 500 x 400mm	Ø 500 x 400mm	Distribution box
Mesh size screen (PP) with stainless steel (SS) mesh	120 µm	120 µm	
Max. Flow	50 m ³	40 m ³	30 m ³
Max. pond volume	100 m ³	80 m ³	
Max. pond volume with koi	50 m ³	40 m ³	
Inlet (mm)	5 x 110mm	5 x 110mm	1x 110mm
Outlet (mm)	2 x 110mm	2 x 110mm	
Internal flushing pump	SS 5 bar/750 watt 220V	SS 5 bar/750watt 220V	
Industrial motor	130Nm/60 watt 220V	130Nm/60 watt 220V	
Built-in UVC unit	80 watt H-O	80 watt H-O	
Air supply	4 x 50 x 300mm	4 x 50 x 300mm	
Control box	including	including	
Item no.	WMC40ROG	WMC40ROP	WMC40ROT

Spare parts & biological filter media

Product	Item no.
Replacement UV-C HO 80 W lamp for SS housing	RLM0021
HO 80 W quartz sleeve	QS0006
Inox Excellent 80 watt electrical unit	EPM0003EX
Sieve panel 2 x 750 x 400mm Ø 50	ZS00006EX
3m ² Japanese mat 50mm open surface area 645 2m ² m ³ (optional)	3001484
Hel-X 13x12mm 955m ² m ³ 150 liter (optional)	3001139



Discover the complete Excellent series

Combi Drum 50/70 ROTATE

Refined and optimized

Through the acquisition and practical application of knowledge, a new and unique filter series has been developed. Existing technologies have been further refined and optimized. We proudly present our high-quality filter: the Filtreau Excellent series. This series can be easily expanded with an optional UV-C HO 80 W unit, allowing for a fully configurable system that contributes to a clear and clean pond. It supports the breakdown of ammonia, nitrite and nitrate. As the Filtreau Excellent filters are entirely developed in-house, every aspect has been carefully considered.

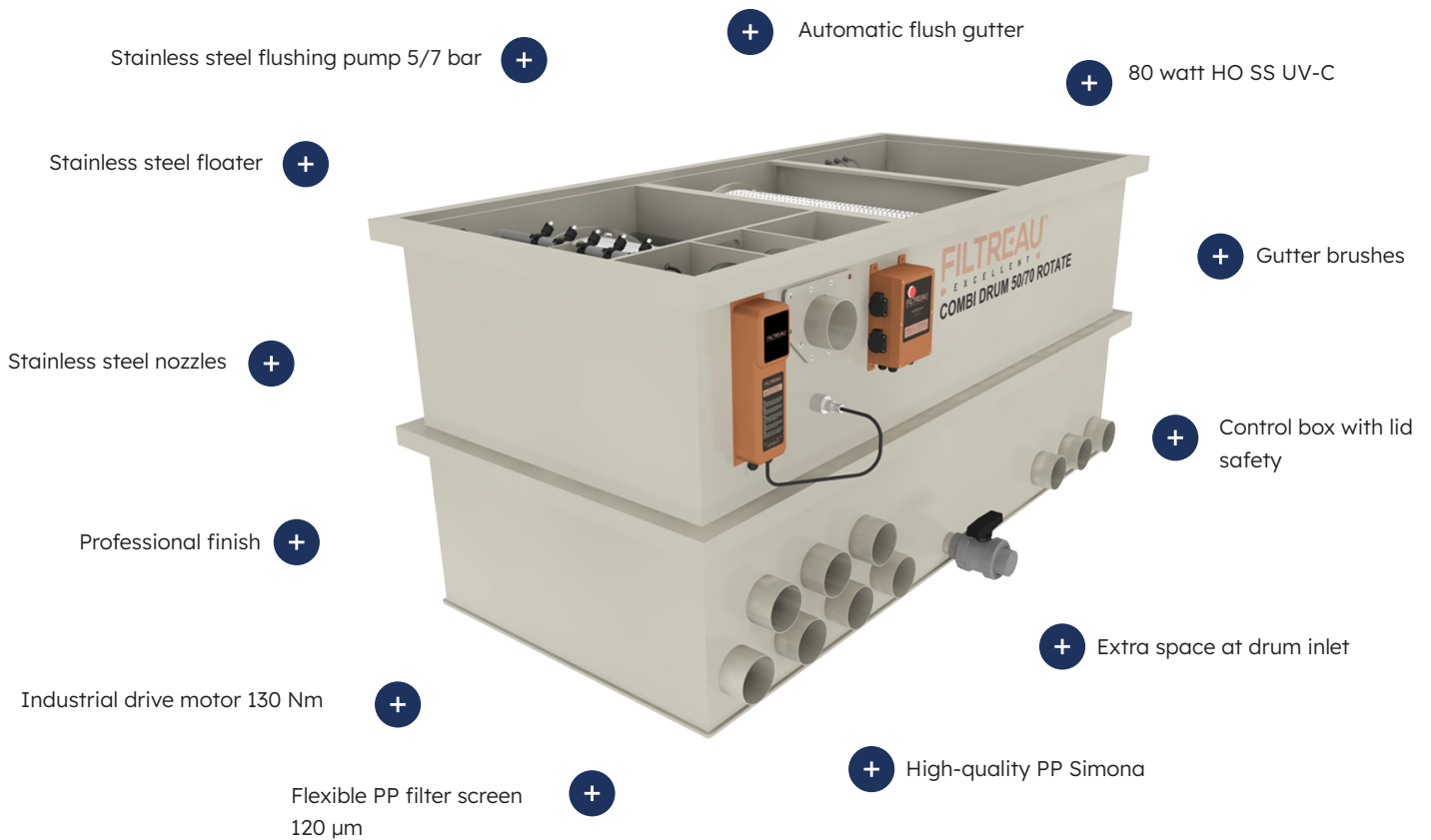

Combi drum Rotate

The operation of a Combi Drum Rotate is exactly the same as that of a combi drum filter or inline filter. The Combi Drum Rotate features a rotating biological chamber filled with Hel-X, which does not require any additional pump head.

Nitrifying bacteria attach to the Hel-X, enabling the breakdown of ammonia and nitrite. In addition, the rotating biological system provides extra oxygenation of the pond.





EXCELLENT LIJN

The control box of the Excellent series comes standard with:

Automatic cleaning: float switch. **Manual operation:** turn button / rinse. **Drum flushing time:** 10 sec. **Flushing level (gravity-fed):** adjustable. **Flushing level (pump-fed):** not adjustable. **Power outlets:** flushing pump, pond pump, drum drive motor and UV-C HO 80 W (SS). **Dry-run protection deactivation:** 30 sec (UV-C lamp). **Flush protection:** after 5 minutes of continuous flushing, the control box switches off, manual reset required. **Magnetic safety switch:** opening the lid switches off the control box.

Technical specifications

			
Product	COMBI DRUM 50/70 ROTATE GRAVITY	COMBI DRUM 50/70 ROTATE PUMP	TRICKLE FOR COMBI DRUM 50/70 ROTATE
Length x width x height	2900 x 850 x 1005mm	2900 x 850 x 1005mm	1240 x 320 x 808mm
Drum	Ø 650 x 400mm	Ø 650 x 400mm	Distribution box
Mesh size screen (PP) with stainless steel (SS) mesh	120 µm	120 µm	
Max. Flow	70 m ³	55 m ³	30 m ³
Max. pond volume	140 m ³	110 m ³	
Max. pond volume with koi	70 m ³	55 m ³	
Inlet (mm)	7 x 110mm	7 x 110mm	1x 110mm
Outlet (mm)	3 x 110mm	3 x 110mm	
Internal flushing pump	SS 5 bar/750 watt 220V	SS 5 bar/750 watt 220V	
Industrial motor	130Nm/60 watt 220/230V	130Nm/60 watt 220/230V	
Built-in UVC unit	80 watt H-O	80 watt H-O	
Air supply	4 x 50 x 300mm	4 x 50 x 300mm	
Control box	including	including	
Item no.	WMC41ROG	WMC41ROP	WMC41ROT

Spare parts & biological filter media

Product	Item no.
Replacement UV-C HO 80 W lamp for SS housing	RLM0021
HO 80 W quartz sleeve	QS0006
Elektrisch gedeelt Inox Excellent 80 watt	EPM0003EX
Sieve panel 2 x 1000 x 400mm Ø 65	ZS00007EX
4,5m ² Japanse mat 50mm open surface area 645 2m ² m ³ (optional)	3001484
Hel-X 13x12mm 955m ² m ³ 150 liter (optional)	3001139



Discover the
complete Excellent
series

Combi Drum 30/40 LOW MOUNTAIN TREE

Refined and optimized

Through the acquisition and practical application of knowledge, a new and unique filter series has been developed. Existing technologies have been further refined and optimized. We proudly present our high-quality filter: the Filtreau Excellent series. This series can be easily expanded with an optional UV-C HO 80 W unit, allowing for a fully configurable system that contributes to a clear and clean pond. It supports the breakdown of ammonia, nitrite and nitrate. As the Filtreau Excellent filters are entirely developed in-house, every aspect has been carefully considered.

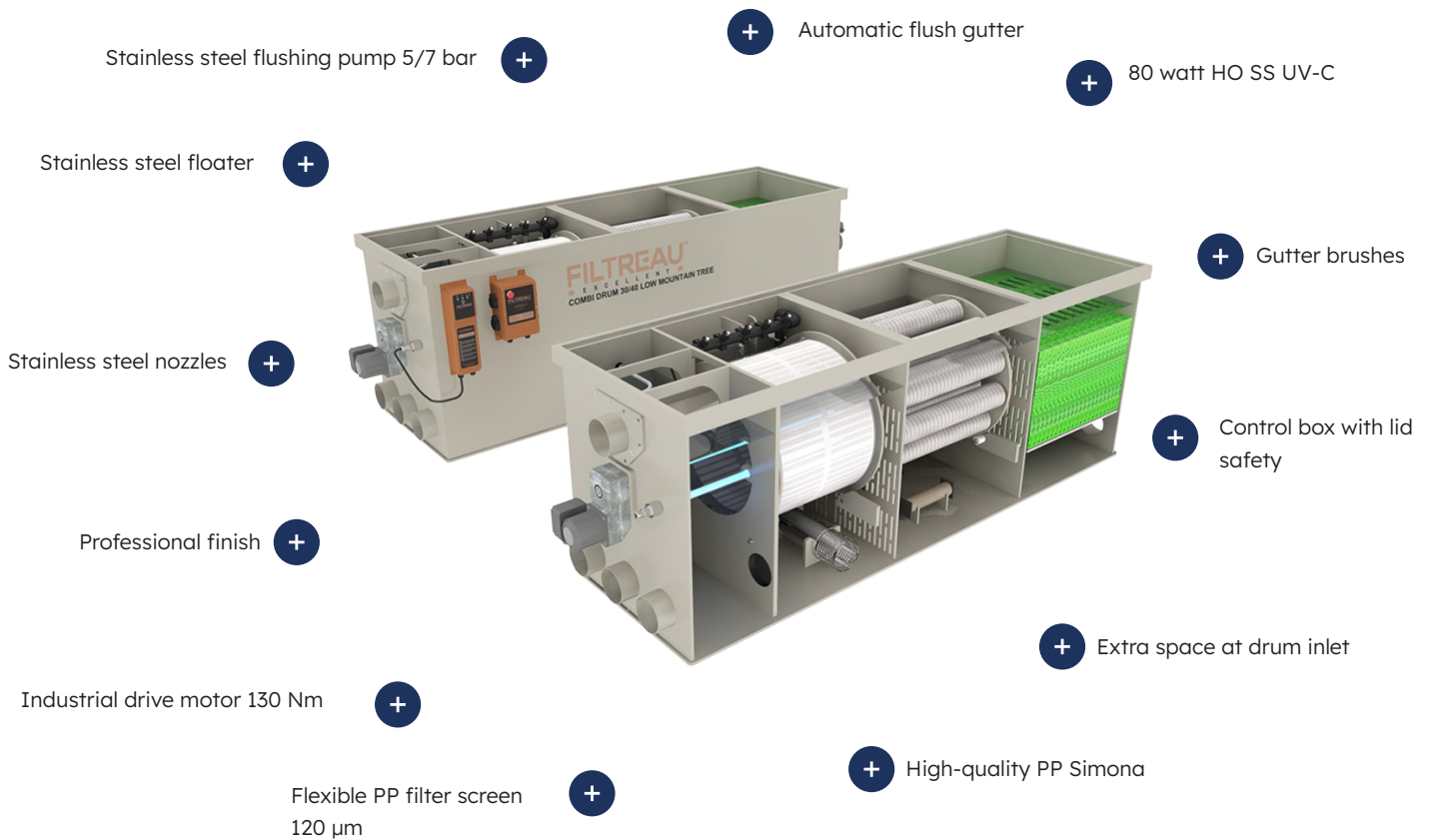

Combi drum Mountain Tree

The filters are designed for both koi ponds and swimming ponds, contributing to a clear, healthy and stable pond environment. By using durable materials such as CNC-cut polypropylene and SS 316/304, the systems are resistant to intensive use and weather conditions. Each filter is CE-certified and supplied with a comprehensive manual and a two-year manufacturer's warranty.

- + Mountain Tree Lotus Root Bacteria House I
- + Mountain Tree Lotus Root Bacteria House II
- + Mountain Tree Spiral Filter Mat

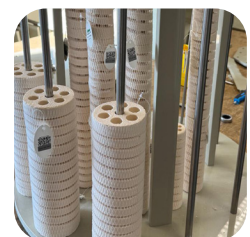
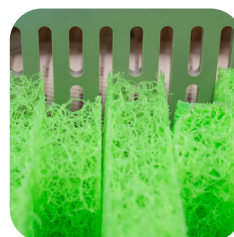
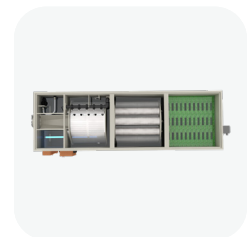
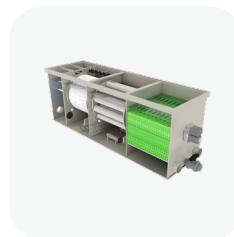

Combi Drum 30/40 LOW MOUNTAIN TREE

The control box of the Excellent Mountain Tree series comes standard with:

Automatic cleaning: float switch. **Manual operation:** turn button / rinse. **Drum flushing time:** 10 sec. **Flushing level (gravity-fed):** adjustable. **Flushing level (pump-fed):** not adjustable. **Power outlets:** flushing pump, pond pump, drum drive motor and UV-C HO 80 W (SS). **Dry-run protection deactivation:** 30 sec (UVC lamp). **Flush protection:** after 5 minutes of continuous flushing, the control box switches off, manual reset required. **Magnetic safety switch:** opening the lid switches off the control box.

Technical specifications

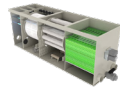

Product	COMBI DRUM 30/40 LOW MOUNTAIN TREE
Length x width x height	2370 x 640 x 750mm
Drum	Ø 500 x 400mm
Screen mesh size (PP) with SS mesh	120 µm
Max. Flow	40 m ³
Max. pond volume	80 m ³
Max. pond volume with koi	40 m ³
Inlet (mm)	3 x 110mm
Outlet (mm)	2 x 110mm
Internal flushing pump	SS 5 bar/750 watt 220V
Industrial motor	2x 130Nm/60 watt 220V
Built-in UVC unit	80 watt H-O
Air supply	4 x 50 x 300mm
Control box	5 x nozzles with sieve (+/-5 L)
Spiral filter mat green	surface 550 m ² /m ³
Item no.	WMC43MTG

Spare parts & biological filter media

Product	Item no.
Replacement lamp UV-C HO 80 watt	RLM0021
HO 80 W quartz sleeve	QS0006
Inox Excellent 80 watt electrical unit	EPM0003EX
Sieve panel 2 x 750 x 400mm Ø 50	ZS00006EX
Lotus Root bacteria house II (surface 4303 m ² /m ³)	Including
Lotus Root bacteria house I (surface 3380 m ² /m ³)	Including



**Discover the
complete Excellent
series**

Combi Drum 50/65 XL MOUNTAIN TREE

Refined and optimized

Through the acquisition and practical application of knowledge, a new and unique filter series has been developed. Existing technologies have been further refined and optimized. We proudly present our high-quality filter: the Filtreau Excellent series. This series can be easily expanded with an optional UV-C HO 80 W unit, allowing for a fully configurable system that contributes to a clear and clean pond. It supports the breakdown of ammonia, nitrite and nitrate. As the Filtreau Excellent filters are entirely developed in-house, every aspect has been carefully considered.

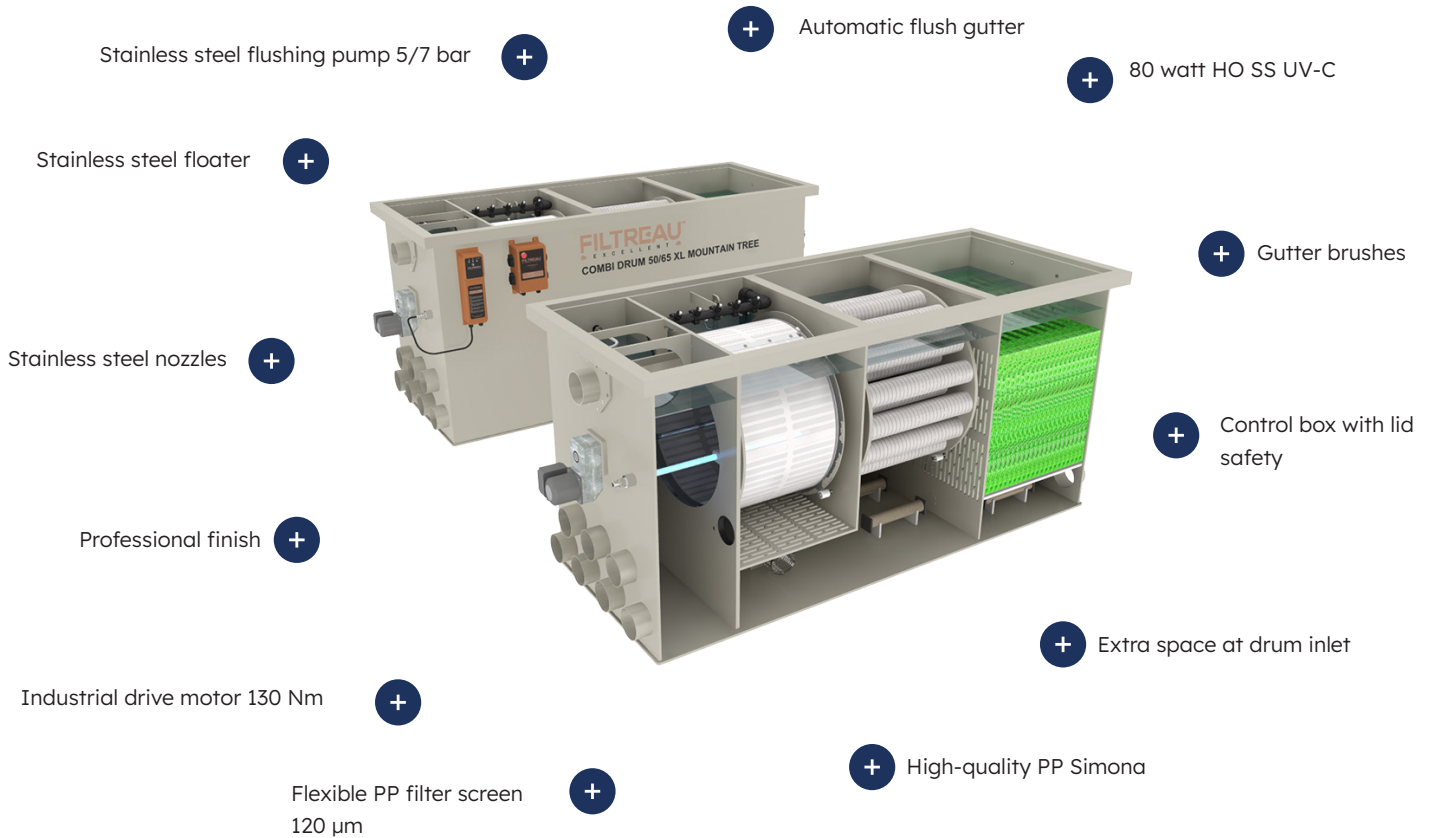

Combi drum Mountain Tree

The filters are designed for both koi ponds and swimming ponds, contributing to a clear, healthy and stable pond environment. By using durable materials such as CNC-cut polypropylene and SS 316/304, the systems are resistant to intensive use and weather conditions. Each filter is CE-certified and supplied with a comprehensive manual and a two-year manufacturer's warranty.

- + Mountain Tree Lotus Root Bacteria House I
- + Mountain Tree Lotus Root Bacteria House II
- + Mountain Tree Spiral Filter Mat

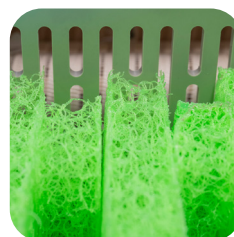

Combi Drum 50/65 XL MOUNTAIN TREE

The control box of the Excellent Mountain Tree series comes standard with:

Automatic cleaning: float switch. **Manual operation:** turn button / rinse. **Drum flushing time:** 10 sec. **Flushing level (gravity-fed):** adjustable. **Flushing level (pump-fed):** not adjustable. **Power outlets:** flushing pump, pond pump, drum drive motor and UV-C HO 80 W (SS). **Dry-run protection deactivation:** 30 sec (UVC lamp). **Flush protection:** after 5 minutes of continuous flushing, the control box switches off, manual reset required. **Magnetic safety switch:** opening the lid switches off the control box.

Technical specifications



Product	COMBI DRUM 50/65 XL MOUNTAIN TREE
Length x width x height	2370 x 790 x 1005mm
Drum	Ø 650 x 400mm
Screen mesh size (PP) with SS mesh	120 µm
Max. Flow	65 m ³
Max. pond volume	130 m ³
Max. pond volume with koi	65 m ³
Inlet (mm)	7 x 110mm
Outlet (mm)	3 x 110mm
Internal flushing pump	SS 5 bar/750 watt 220V
Industrial motor	2x 130Nm/60 watt 220V
Built-in UVC unit	80 watt H-O
Air supply	4 x 50 x 300mm
Control box	5 x nozzles with sieve (+/-5 L)
Spiral filter mat green	surface 550 m ² /m ³
Item no.	WMC44MTG

Spare parts & biological filter media

Product	Item no.
Replacement lamp UV-C HO 80 watt	RLM0021
HO 80 W quartz sleeve	QS0006
Inox Excellent 80 watt electrical unit	EPM0003EX
Sieve panel 2 x 1000 x 400mm Ø 65mm	ZS00006EX
Lotus Root bacteria house II (surface 4303 m ² /m ³)	Including
Lotus Root bacteria house I (surface 3380 m ² /m ³)	Including



Discover the complete Excellent series

Combi Drum 30/50 LOW MOUNTAIN TREE

Refined and optimized

Through the acquisition and practical application of knowledge, a new and unique filter series has been developed. Existing technologies have been further refined and optimized. We proudly present our high-quality filter: the Filtreau Excellent series. This series can be easily expanded with an optional UV-C HO 80 W unit, allowing for a fully configurable system that contributes to a clear and clean pond. It supports the breakdown of ammonia, nitrite and nitrate. As the Filtreau Excellent filters are entirely developed in-house, every aspect has been carefully considered.

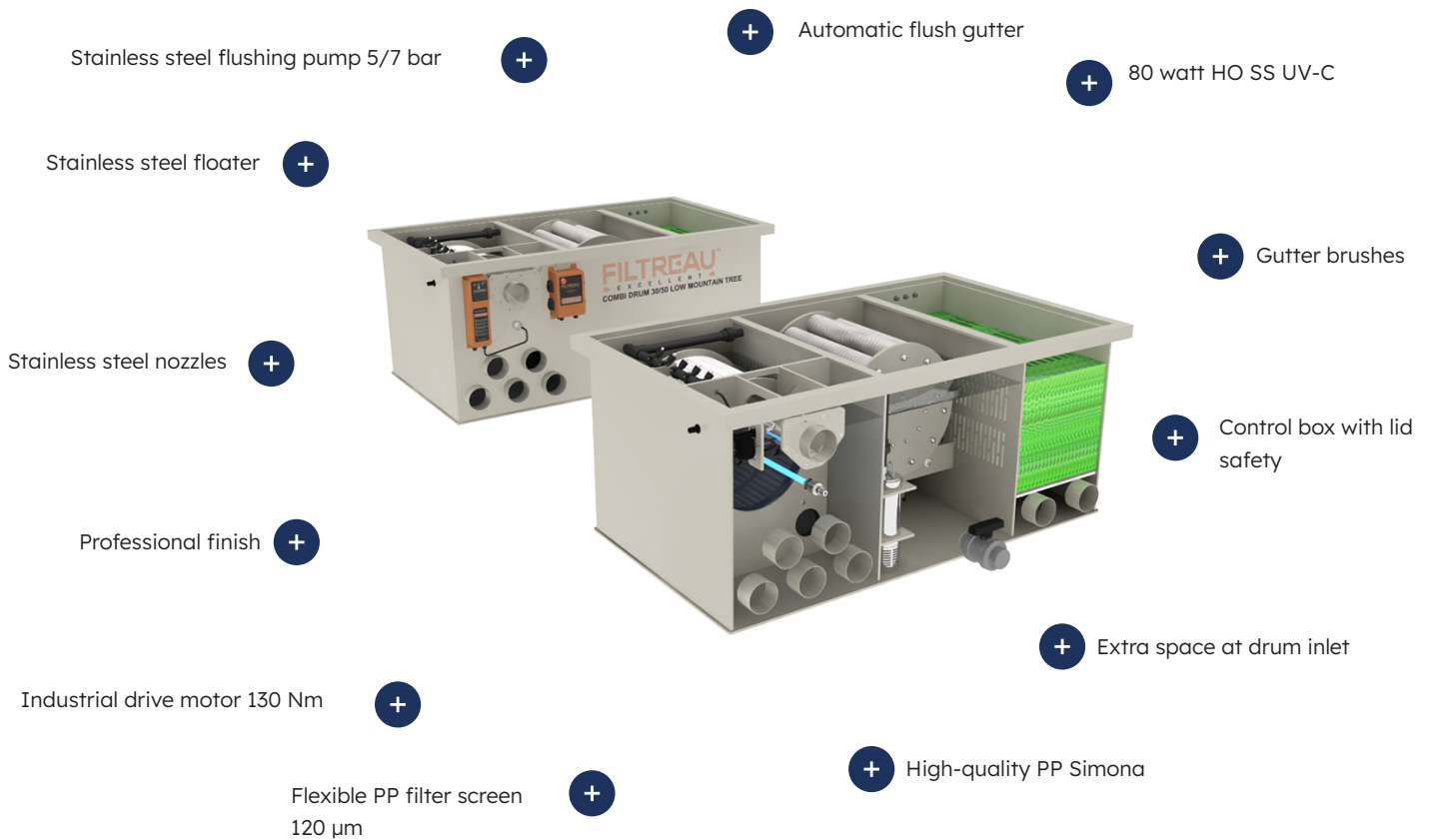

Combi drum Mountain Tree

The filters are designed for both koi ponds and swimming ponds, contributing to a clear, healthy and stable pond environment. By using durable materials such as CNC-cut polypropylene and SS 316/304, the systems are resistant to intensive use and weather conditions. Each filter is CE-certified and supplied with a comprehensive manual and a two-year manufacturer's warranty.

- Mountain Tree Lotus Root Bacteria House I
- Mountain Tree Lotus Root Bacteria House II
- Mountain Tree Spiral Filter Mat

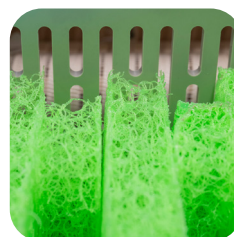

Combi Drum 30/50 LOW MOUNTAIN TREE

The control box of the Excellent Mountain Tree series comes standard with:

Automatic cleaning: float switch. **Manual operation:** turn button / rinse. **Drum flushing time:** 10 sec. **Flushing level (gravity-fed):** adjustable. **Flushing level (pump-fed):** not adjustable. **Power outlets:** flushing pump, pond pump, drum drive motor and UV-C HO 80 W (SS). **Dry-run protection deactivation:** 30 sec (UVC lamp). **Flush protection:** after 5 minutes of continuous flushing, the control box switches off, manual reset required. **Magnetic safety switch:** opening the lid switches off the control box.

Technical specifications



Product	COMBI DRUM 30/50 LOW MOUNTAIN TREE
Length x width x height	1773 x 1163 x 750mm
Drum	Ø 500 x 400mm
Screen mesh size (PP) with SS mesh	120 µm
Max. Flow	50 m ³
Max. pond volume	100 m ³
Max. pond volume with koi	50 m ³
Inlet (mm)	3 x 110mm
Outlet (mm)	2 x 110mm
Internal flushing pump	SS 5 bar/750 watt 220V
Industrial motor	2x 130Nm/60 watt 220V
Built-in UVC unit	80 watt H-O
Air supply	4 x 50 x 300mm
Control box	5 x nozzles with sieve (+/-5 L)
Spiral filter mat green	surface 550 m ² /m ³
Item no.	WMC45MTG

Spare parts & biological filter media

Product	Item no.
Replacement lamp UV-C HO 80 watt	RLM0021
HO 80 W quartz sleeve	QS0006
Inox Excellent 80 watt electrical unit	EPM0003EX
Sieve panel 2 x 750 x 400mm Ø 50mm	ZS00006EX
Lotus Root bacteria house II (surface 4303 m ² /m ³)	Including
Lotus Root bacteria house I (surface 3380 m ² /m ³)	Including



Discover the complete Excellent series

Combi Drum 50/70 MOUNTAIN TREE

Refined and optimized

Through the acquisition and practical application of knowledge, a new and unique filter series has been developed. Existing technologies have been further refined and optimized. We proudly present our high-quality filter: the Filtreau Excellent series. This series can be easily expanded with an optional UV-C HO 80 W unit, allowing for a fully configurable system that contributes to a clear and clean pond. It supports the breakdown of ammonia, nitrite and nitrate. As the Filtreau Excellent filters are entirely developed in-house, every aspect has been carefully considered.

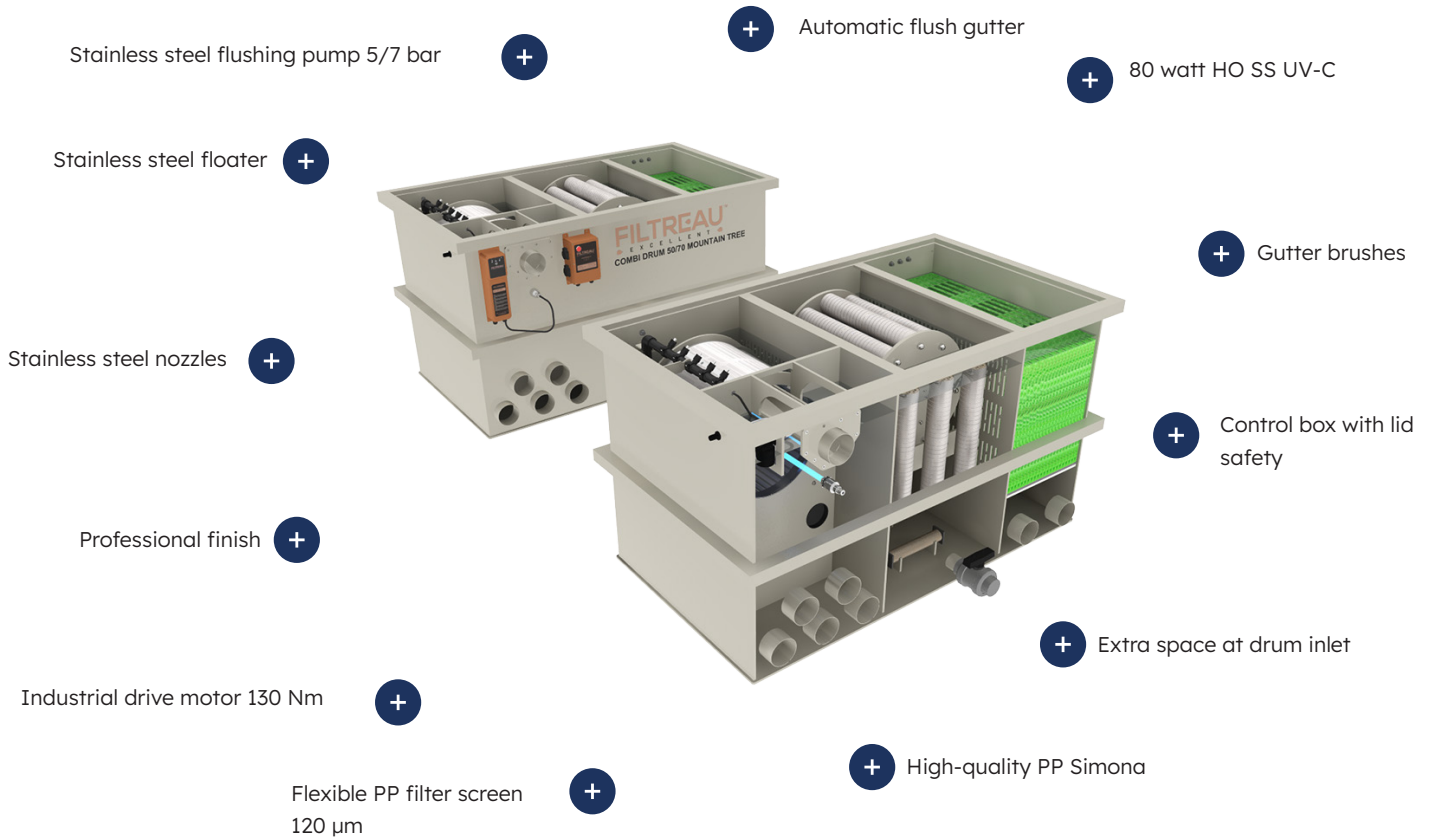

Combi drum Mountain Tree

The filters are designed for both koi ponds and swimming ponds, contributing to a clear, healthy and stable pond environment. By using durable materials such as CNC-cut polypropylene and SS 316/304, the systems are resistant to intensive use and weather conditions. Each filter is CE-certified and supplied with a comprehensive manual and a two-year manufacturer's warranty.

- Mountain Tree Lotus Root Bacteria House I
- Mountain Tree Lotus Root Bacteria House II
- Mountain Tree Spiral Filter Mat

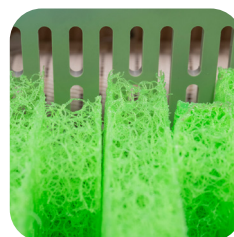
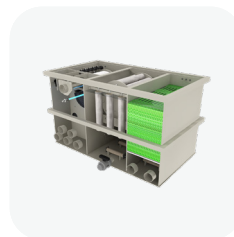

Combi Drum 50/70 MOUNTAIN TREE

The control box of the Excellent Mountain Tree series comes standard with:

Automatic cleaning: float switch. **Manual operation:** turn button / rinse. **Drum flushing time:** 10 sec. **Flushing level (gravity-fed):** adjustable. **Flushing level (pump-fed):** not adjustable. **Power outlets:** flushing pump, pond pump, drum drive motor and UV-C HO 80 W (SS). **Dry-run protection deactivation:** 30 sec (UVC lamp). **Flush protection:** after 5 minutes of continuous flushing, the control box switches off, manual reset required. **Magnetic safety switch:** opening the lid switches off the control box.

Technical specifications



Product	COMBI DRUM 50/70 MOUNTAIN TREE
Length x width x height	1773 x 1163 x 1005mm
Drum	Ø 500 x 400mm
Screen mesh size (PP) with SS mesh	120 µm
Max. Flow	50 m ³
Max. pond volume	100 m ³
Max. pond volume with koi	50 m ³
Inlet (mm)	3 x 110mm
Outlet (mm)	2 x 110mm
Internal flushing pump	SS 5 bar/750 watt 220V
Industrial motor	2x 130Nm/60 watt 220V
Built-in UVC unit	80 watt H-O
Air supply	4 x 50 x 300mm
Control box	5 x nozzles with sieve (+/-5 L)
Spiral filter mat green	surface 550 m ² /m ³
Item no.	WMC46MTG

Spare parts & biological filter media

Product	Item no.
Replacement lamp UV-C HO 80 watt	RLM0021
HO 80 W quartz sleeve	QS0006
Inox Excellent 80 watt electrical unit	EPM0003EX
Sieve panel 2 x 750 x 400mm Ø 50mm	ZS00006EX
Lotus Root bacteria house II (surface 4303 m ² /m ³)	Including
Lotus Root bacteria house I (surface 3380 m ² /m ³)	Including



Discover the complete Excellent series

Combi Drum 80/100 XXL MOUNTAIN TREE

Refined and optimized

Through the acquisition and practical application of knowledge, a new and unique filter series has been developed. Existing technologies have been further refined and optimized. We proudly present our high-quality filter: the Filtreau Excellent series. This series can be easily expanded with an optional UV-C HO 80 W unit, allowing for a fully configurable system that contributes to a clear and clean pond. It supports the breakdown of ammonia, nitrite and nitrate. As the Filtreau Excellent filters are entirely developed in-house, every aspect has been carefully considered.

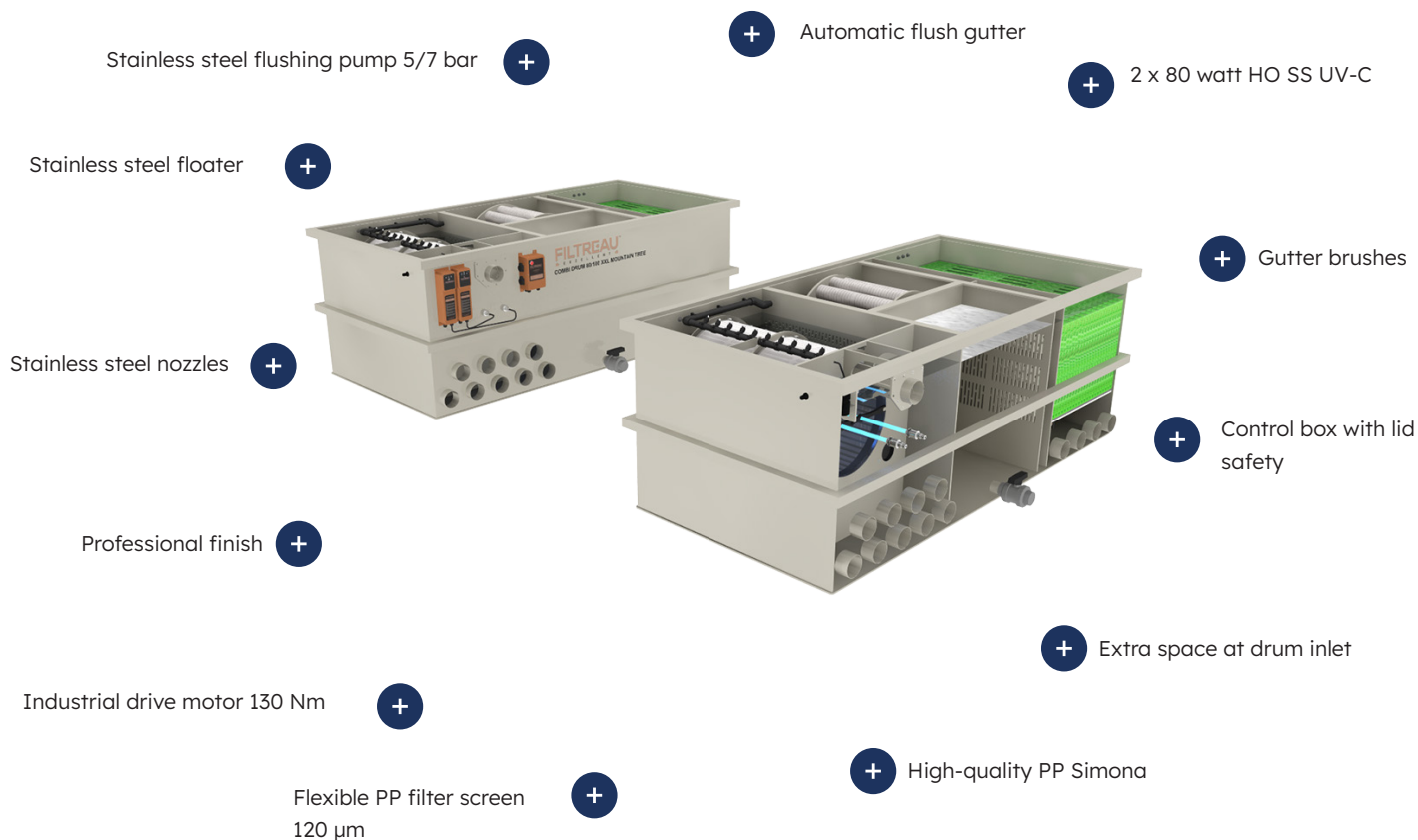

Combi drum Mountain Tree

The filters are designed for both koi ponds and swimming ponds, contributing to a clear, healthy and stable pond environment. By using durable materials such as CNC-cut polypropylene and SS 316/304, the systems are resistant to intensive use and weather conditions. Each filter is CE-certified and supplied with a comprehensive manual and a two-year manufacturer's warranty.

- Mountain Tree Lotus Root Bacteria House I
- Mountain Tree Lotus Root Bacteria House II
- Mountain Tree Spiral Filter Mat



Combi Drum 80/100 XXL MOUNTAIN TREE

The control box of the Excellent Mountain Tree series comes standard with:

Automatic cleaning: float switch. **Manual operation:** turn button / rinse. **Drum flushing time:** 10 sec. **Flushing level (gravity-fed):** adjustable. **Flushing level (pump-fed):** not adjustable. **Power outlets:** flushing pump, pond pump, drum drive motor and UV-C HO 80 W (SS). **Dry-run protection deactivation:** 30 sec (UVC lamp). **Flush protection:** after 5 minutes of continuous flushing, the control box switches off, manual reset required. **Magnetic safety switch:** opening the lid switches off the control box.

Technical specifications



Product	COMBI DRUM 80/100 XXL MOUNTAIN TREE
Length x width x height	2760 x 1515 x 1005mm
Drum	Ø 650 x 800mm
Screen mesh size (PP) with SS mesh	120 µm
Max. Flow	80 m ³
Max. pond volume	160 m ³
Max. pond volume with koi	80 m ³
Inlet (mm)	7 x 110mm
Outlet (mm)	3 x 110mm
Internal flushing pump	SS 5 bar/750 watt 220V
Industrial motor	2x 130Nm/60 watt 220V
Built-in UVC unit	2 x 80 watt H-O
Air supply	6 x 50 x 300mm
Control box	5 x nozzles with sieve (+/-5 L)
Spiral filter mat green	surface 550 m ² /m ³
Item no.	WMC47MTG

Spare parts & biological filter media

Product	Item no.
Replacement lamp UV-C HO 80 watt	RLM0021
HO 80 W quartz sleeve	QS0006
Inox Excellent 80 watt electrical unit	EPM0003EX
Sieve panel 2 x 1000 x 400mm Ø 65mm	ZS00006EX
Hel-X 13 x 12 mm (surface 955 m ² /m ³)	Including
Lotus Root bacteria house II (surface 4303 m ² /m ³)	Including
Lotus Root bacteria house I (surface 3380 m ² /m ³)	Including



Discover the complete Excellent series

Leaf Catcher

Optimal pre-filtration for maximum protection of the drum filter

The Filtreau Leaf Catcher has been developed as a robust pre-filtration solution for ponds with a high leaf load. By effectively capturing coarse debris such as leaves and twigs before the water reaches the drum filter, clogging of the flushing outlet is prevented and the entire filtration system continues to operate optimally.

The Leaf Catcher is specifically designed for gravity-fed installations and serves as a reliable first barrier within the filtration process. This significantly reduces the load on the drum, resulting in more stable performance and reduced maintenance.

WMC381LS

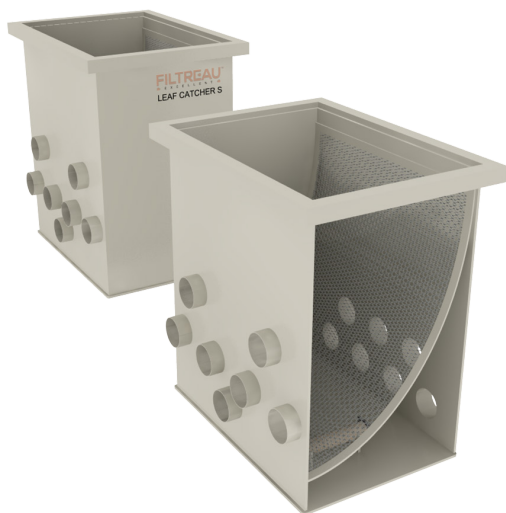

WMC381LB

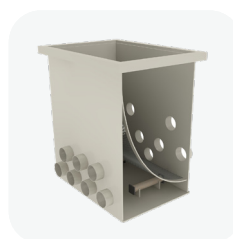
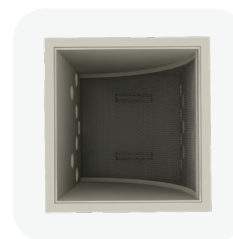
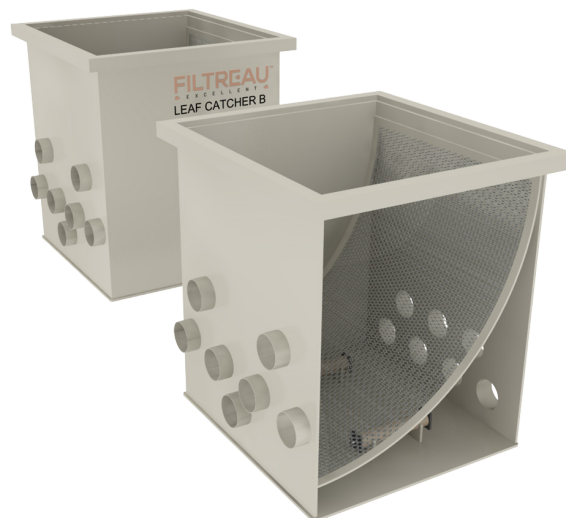

Leaf Catcher

Efficient coarse debris removal

The filter is equipped with a PP screen with stainless steel mesh, effectively removing coarse debris from the water flow. This prevents accumulation in the drum and protects the outlet from clogging, especially in ponds surrounded by trees or subject to heavy leaf fall. By strategically placing the Leaf Catcher in front of the drum filter, the lifespan of the entire filtration system is extended and optimal flow is maintained.

Technical specifications



Product	LEAF CATCHER S	LEEAF CATCHER B
Length x width x height	950 x 700 x 1005mm	2760 x 1515 x 1005mm
Drum	Ø 650 x 800mm	Ø 650 x 800mm
Screen mesh size (PP) with SS mesh	120 µm	120 µm
Max. Flow	65 m ³	100 m ³
Max. pond volume	130 m ³	150 m ³
Inlet (mm)	6 x 110mm	6 x 110mm
Outlet (mm)	7 x 110mm	7 x 110mm
Materials	Housing PP PP 10mm	Housing PP PP 10mm
Item no.	WMC38ILS	WMC38ILB



**Discover the
complete Excellent
series**

Excellent Koi Bowl

Optimal visibility, professional presentation and inspection of koi

The Filtreau Excellent Koi Bowl is the ultimate stage for your top-quality koi. Presentation is key to success, whether you are a proud breeder looking to sell your fish or a hobbyist showcasing your koi at an international koi show.

The Filtreau Excellent Koi Bowl offers the perfect balance between aesthetics, fish safety and ease of use. At Wimaca International BV, we understand that a healthy koi delivers the best results. Our bowls are specifically designed to allow the fish to be observed calmly and safely.



Excellent Koi Bowl

The Filtreau Excellent Koi Bowl is suitable for:

- + Quarantine tank
- + Presenting during sales events or koi shows

Koi Bowl

Ideal for controlled dosing of medication

The professional solution for presenting, holding or temporarily housing pond fish. With its luxurious, rounded design and high-quality finish, this fish tank is a true eye-catcher in any koi store or breeding facility. Made from durable 10 mm polypropylene (PP), the Koi Bowl offers the perfect balance between strength, lightweight construction and ease of use. The smooth surface is easy to clean and completely safe for all pond fish. An optional pump can be added to create additional water movement (not included).

Key features

Optimal swimming comfort: Thanks to its spacious design, your koi can swim freely, minimizing stress and keeping the fish in optimal condition during presentation.

Crystal-clear presentation: Combine the bowl with a Filtreau Excellent filter for unmatched water quality. Our filters remove suspended particles down to the finest level, allowing your koi to truly stand out.

Show-ready technology: Designed for both temporary and long-term use at shows. The system is quick to set up and highly reliable thanks to its integrated safety logic.

Custom-made to your specifications: No pond or show environment is the same. We provide custom-made solutions to ensure the bowl and filter perfectly match your specific requirements.

Safety: Equipped with rounded corners and fish-friendly materials.

Hygiene: Easy to clean and disinfect after use.

Modular: Easy to connect to the full WMC Excellent filter range.

Technical specifications



Product	Koi Bowl 1650 x 1000 x 10mm
Dimensions	1650 x 1000 x 10mm
Item no.	WMC70RVB



Discover the
complete Excellent
series

Photo Bowl Blue

Optimal visibility, professional presentation and inspection of koi

The Filtreau Photo Bowl Blue is the ultimate stage for your top-quality koi. Presentation is key to success, whether you are a proud breeder looking to sell your fish or a hobbyist showcasing your koi at an international koi show. The Filtreau Photo Bowl offers the perfect balance between aesthetics, fish safety and ease of use. At Wimaca International BV, we understand that a healthy koi delivers the best results. Our photo bowls are specifically designed to allow the fish to be observed and photographed calmly and safely. The blue background of the bowl provides maximum contrast, making the colors of the koi stand out vividly.



Photo Bowl Blue

The Filtreau Excellent Photo Bowl is suitable for:

- + Photographing koi
- + Assessing and inspecting color, pattern and skin quality
- + Showcasing koi at sales events or koi shows
- + Temporary transport or transfer of koi



[View all Photo Bowl's](#)

Photo Bowl Blue

Ideal for photography and controlled dosing of medication

The professional solution for presenting, holding or temporarily housing pond fish. With its luxurious, rounded design and high-quality finish, this fish tank is a true eye-catcher in any koi store or breeding facility. Made from durable 10 mm polyethylene (PE), the Koi Bowl offers the perfect balance between strength, lightweight construction and ease of use. The smooth surface is easy to clean and completely safe for all pond fish. An optional pump can be added to create additional water movement (not included).

Technical specifications



Product	Photo Bowl Ø 800 x 500 mm	Photo Bowl Ø 960 x 500 mm	Photo Bowl Ø 1200 x 500 mm
Dimensions	Ø 800 x 500mm	Ø 960 x 500mm	Ø 1200 x 500mm
Item no.	WMC76RVB	WMC77RVB	WMC78RVB



**Discover the
complete Excellent
series**

Why choose a FILTREAU filter?

- ✓ Sustainable Production
- ✓ Custom-made / Private Label
- ✓ Price-performance Ration
- ✓ Service-driven
- ✓ 100% produced in The Netherlands

40+ years experience

Low prices, high quality

Our years of experience mean that we know exactly what works and what doesn't. This puts us in an excellent position to market high quality water filtration products. We keep our prices low by developing and producing all products in-house.

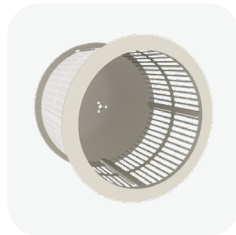

Your own brand name

Private label

Bringing our products to market under your own brand name? That's possible at Wimäca.

Together we look at your wishes and we can fully shape our products in your own style.

From your own packaging and user manuals to various promotional materials for trade shows and even a website in your look and feel. Wimäca offers countless possibilities to bring your product to market under your own name.

+62 countries

Worldwide shipping

Wimäca International develops and produces all its (Filtreau) products in the Netherlands.

From our base in Son en Breugel, we serve the professional market worldwide.

We supply customers in over 62 countries.



Basic series

High-quality standards

BASIC LINE

Perfect water quality in a simple and reliable way

Filtreau offers high-quality filtration systems and pumps designed for ponds and koi ponds. Our products are developed using extensive expertise, advanced technologies and premium professional materials.

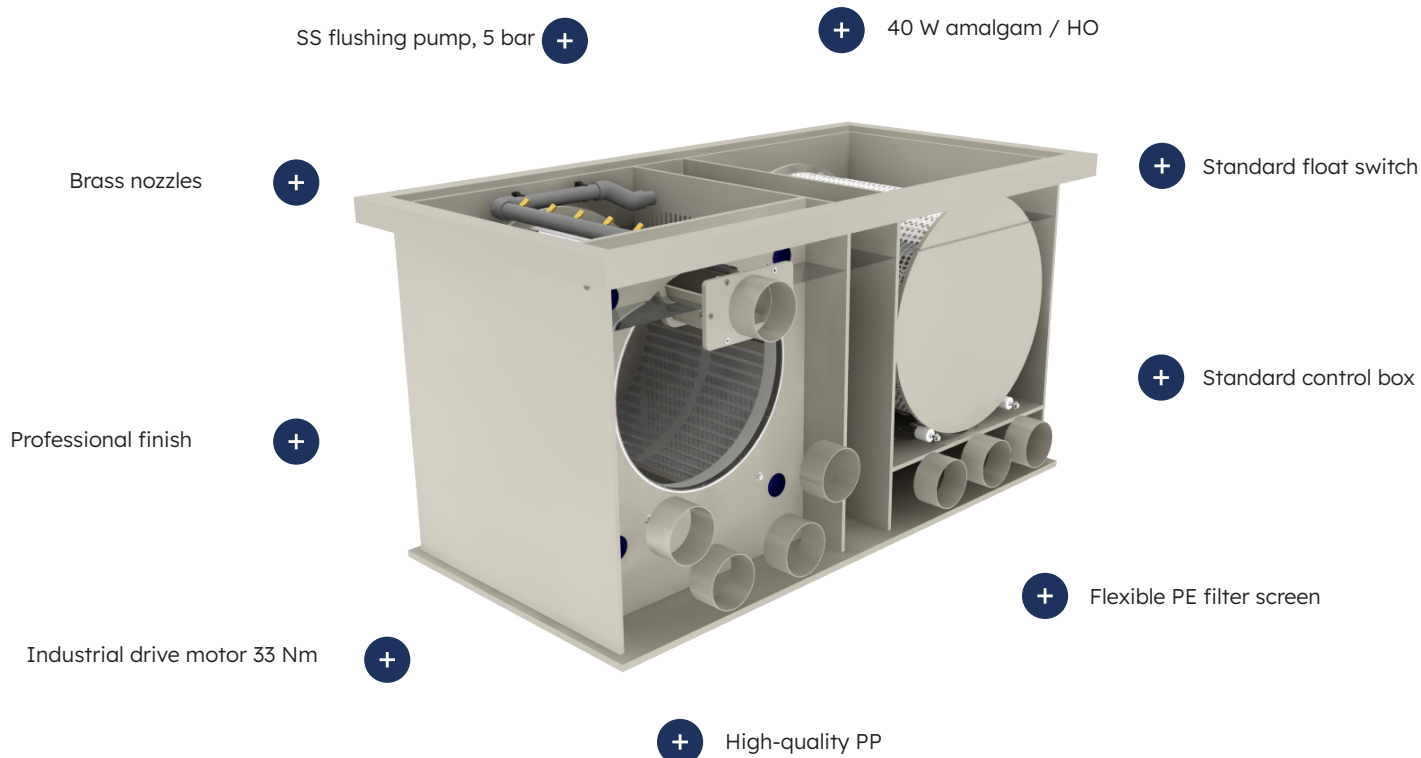

✔ Sustainable production

✔ 40 years experience

✔ Private label / Custom solutions

Drum filter

A pre-filter is a drum filter that efficiently removes very fine debris (70 μm / 120 μm) from the water. The water enters the drum filter either pump-fed or gravity-fed, where contaminants are separated from the water.

The water flows from the inside of the drum through the filter screen to the outside of the unit. The debris remains on the sieve panel (PE), which is mounted on the drum. The sieve panel (PE) is fitted with a fine SS mesh (70 μm / 120 μm).

The debris is rinsed off the sieve panel (PE) by means of brass or plastic nozzles and collected in the gutter. The cleaning frequency depends on the level of contamination of the pond water.



Combi drum filter

Our combi drum filters are equipped with an innovative drum filtration system which, combined with a moving bed filter, ensures optimal water flow and filtration. First, the contaminated pond water enters the collection chamber. The second chamber provides mechanical filtration and houses the drum filter.

In the third chamber, an air disc or air stone is installed at the bottom. This must be connected to an external air pump to create movement within the chamber. For optimal performance, this chamber should be filled to a maximum of 70% of its volume with moving bed media such as Hel-X. After several weeks, beneficial bacteria will attach to the Hel-X, enabling biological filtration of the water. As the media is continuously in motion, no debris can accumulate. This keeps the media clean and results in little to no maintenance.



Combi drum inline filter

The operation of a combi drum inline filter is exactly the same as that of a combi drum filter. The advantage of a combi drum inline filter is that all connections are located on one end of the system. This optimizes the installation of the combi drum inline filter.

Combi drum rotate

The operation of a Combi Drum Rotate is exactly the same as that of a combi drum filter or inline filter. The Combi Drum Rotate features a rotating biological chamber filled with Hel-X, which does not require any additional pump head. Nitrifying bacteria attach to the Hel-X, enabling the breakdown of ammonia and nitrite. In addition, the rotating biological system provides extra oxygenation of the pond.

Trickle filter / Bakki shower

Trickle filters effectively convert harmful dissolved waste substances (nitrite, proteins, ammonium, etc.) in the pond water into harmless compounds. The water first enters the inlet chamber at the top, where it is then evenly distributed over the click grids.

Below this, the elements are placed, also equipped with click grids, allowing the water to flow through easily. The elements can be filled with the desired filter media. This ensures optimal oxygen saturation of the water. Due to the high oxygen levels, the risk of oxygen deficiency in the pond is significantly reduced, even during warmer periods.

The trickle filters are precisely manufactured to seamlessly connect to our combi drum filters. This facilitates the integration of a trickle filter in combination with our combi drum filters.

Private label

For a large number of clients, we manufacture UV-C units and filters under private label. Looking to expand your existing product range with your own branded products? Thanks to our many years of expertise, we understand market demands and can guide you throughout this process.

For more information about private label opportunities, please contact our sales department. Our team will be happy to assist you.

DRUM FILTER INCL. UVC

Perfect water quality in a simple and reliable way

Filtreau offers high-quality filtration systems and pumps designed for ponds and koi ponds. Our products are developed using extensive expertise, advanced technologies and premium professional materials.

Brass / plastic nozzles



Professional finish



Industrial drive motor 33 Nm

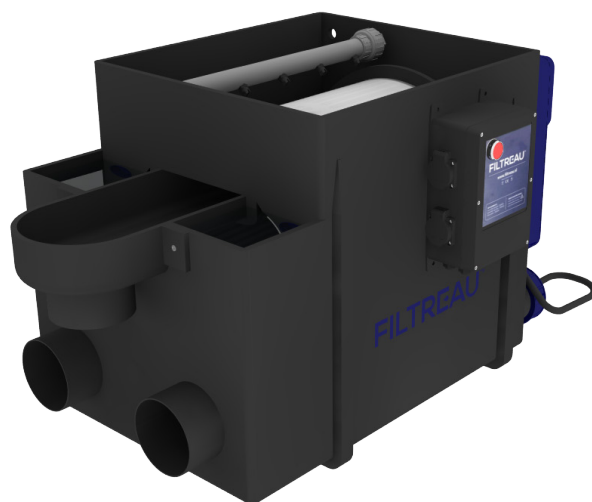

Standard float switch



Standard control box



Flexible PE filter screen



High-quality injection moulding

Drum filter

A pre-filter is a drum filter that efficiently removes very fine debris (70 μm / 120 μm) from the water. The water enters the drum filter either pump-fed or gravity-fed, where contaminants are separated from the water. The water flows from the inside of the drum through the filter screen to the outside of the unit. The debris remains on the sieve panel (PE), which is mounted on the drum. The sieve panel (PE) is fitted with a fine stainless steel mesh (70 μm / 120 μm).

The debris is rinsed off the sieve panel (PE) by means of brass or plastic nozzles and collected in the gutter. The cleaning frequency depends on the level of contamination of the pond water.



BASIC LINE

The control box of the Basic series comes standard with:

Automatic cleaning: float switch. **Manual operation:** turn button / rinse. **Drum flushing time:** 10 sec. **Flushing level (gravity-fed):** adjustable. **Flushing level (pump-fed):** not adjustable. **Power outlets:** flushing pump, pond pump, drum drive motor and UVC. **Dry-run protection deactivation:** 30 sec (UVC lamp).

Technical specifications

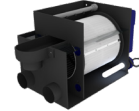
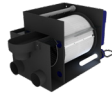

Product	FILTREAU DRUM-FILTER INCL. UVC (GRAVITY)	FILTREAU DRUM-FILTER INCL. UVC (PUMP-FED)
Length x width x height	940 x 485 x 534mm	940 x 485 x 534mm
Drum	Ø 400 x 430mm	Ø 400 x 430mm
Mesh size screen (PP) with stainless steel (SS) mesh	70 µm	70 µm
Max. Flow	20 m ³	15 m ³
Max. pond volume	40 m ³	30 m ³
Max. pond volume with koi	20 m ³	15 m ³
Inlet (mm)	2 x 110mm	2 x 110mm
Outlet (mm)	1 x 110mm	1 x 110mm
Internal flushing pump		
Industrial motor	33Nm/40 watt 220/230V	33Nm/40 watt 220/230V
Built-in UVC unit	1 x 40 watt amalgam	1 x 40 watt amalgam
Air supply		
Control box	including	including
Item no.	TR00001	TR00003

Spare parts

Product	Item no.
Replacement lamp UV-C 40 watt amalgam	RLM0001
Quartz glass 40 watt	QS0001
Sieve panel 1x 1140 x 400mm Ø 40	ZS00001

Notes



Discover the complete Basic series

Drum filter HF30

Perfect water quality in a simple and reliable way

Filtreau offers high-quality filtration systems and pumps designed for ponds and koi ponds. Our products are developed using extensive expertise, advanced technologies and premium professional materials.



Drum filter

A pre-filter is a drum filter that efficiently removes very fine debris (70 µm / 120 µm) from the water. The water enters the drum filter either pump-fed or gravity-fed, where contaminants are separated from the water. The water flows from the inside of the drum through the filter screen to the outside of the unit. The debris remains on the sieve panel (PE), which is mounted on the drum. The sieve panel (PE) is fitted with a fine stainless steel mesh (70 µm / 120 µm).

The debris is rinsed off the sieve panel (PE) by means of brass or plastic nozzles and collected in the gutter. The cleaning frequency depends on the level of contamination of the pond water.



BASIC LINE

The control box of the Basic series comes standard with:

Automatic cleaning: float switch. **Manual operation:** turn button / rinse. **Drum flushing time:** 10 sec. **Flushing level (gravity-fed):** adjustable. **Flushing level (pump-fed):** not adjustable. **Power outlets:** flushing pump, pond pump, drum drive motor and UVC. **Dry-run protection deactivation:** 30 sec (UVC lamp).

Technical specifications

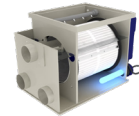
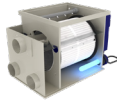

Product	FILTREAU DRUM-FILTER HF30 (GRAVITY) PP	FILTREAU DRUM-FILTER HF30 (PUMP-FED) PP
Length x width x height	840 x 480 x 510mm	840 x 480 x 510mm
Drum	Ø 400 x 430mm	Ø 400 x 430mm
Mesh size screen (PP) with stainless steel (SS) mesh	70 µm	70 µm
Max. Flow	30 m ³	20 m ³
Max. pond volume	60 m ³	40 m ³
Max. pond volume with koi	30 m ³	20 m ³
Inlet (mm)	2 x 110mm	2 x 110mm
Outlet (mm)	2 x 110mm	2 x 110mm
Internal flushing pump		
Industrial motor	33Nm/40 watt 220/230V	33Nm/40 watt 220/230V
Built-in UVC unit	Optional	Optional
Air supply		
Control box	including	including
Item no.	TR00004	TR00005

Spare parts

Product	Item no.
Replacement lamp UV-C 40 watt amalgam	RLM0001
Quartz glass 40 watt	QS0001
Sieve panel 1 x 1147 x 398 x 50mm Ø 40 High Flow	ZH00001

Notes



Discover the complete Basic series

Drum filter HF30 SGP XL motor

Perfect water quality in a simple and reliable way

Filtreau offers high-quality filtration systems and pumps designed for ponds and koi ponds. Our products are developed using extensive expertise, advanced technologies and premium professional materials.



Drum filter

A pre-filter is a drum filter that efficiently removes very fine debris (70 µm / 120 µm) from the water. The water enters the drum filter either pump-fed or gravity-fed, where contaminants are separated from the water. The water flows from the inside of the drum through the filter screen to the outside of the unit. The debris remains on the sieve panel (PE), which is mounted on the drum. The sieve panel (PE) is fitted with a fine stainless steel mesh (70 µm / 120 µm).

The debris is rinsed off the sieve panel (PE) by means of brass or plastic nozzles and collected in the gutter. The cleaning frequency depends on the level of contamination of the pond water.



BASIC LINE

The control box of the Basic series comes standard with:

Automatic cleaning: float switch. **Manual operation:** turn button / rinse. **Drum flushing time:** 10 sec. **Flushing level (gravity-fed):** adjustable. **Flushing level (pump-fed):** not adjustable. **Power outlets:** flushing pump, pond pump, drum drive motor and UVC. **Dry-run protection deactivation:** 30 sec (UVC lamp).

Technical specifications



Product	FILTREAU DRUM-FILTER HF30 (GRAVITY) SPG XL MOTOR	FILTREAU DRUM-FILTER HF30 (PUMP-FED) SPG XL MOTOR
Length x width x height	840 x 480 x 510mm	840 x 480 x 510mm
Drum	Ø 400 x 430mm	Ø 400 x 430mm
Mesh size screen (PP) with stainless steel (SS) mesh	70 µm	70 µm
Max. Flow	30 m ³	20 m ³
Max. pond volume	60 m ³	40 m ³
Max. pond volume with koi	30 m ³	20 m ³
Inlet (mm)	2 x 110mm	2 x 110mm
Outlet (mm)	2 x 110mm	2 x 110mm
Internal flushing pump		
Industrial motor	130Nm/60 watt 220/230V	130Nm/40 watt 220/230V
Built-in UVC unit	Optional	Optional
Air supply		
Control box	including	including
Item no.	TRSPG04	TRSPG05

Spare parts

Product	Item no.
Replacement lamp UV-C 40 watt amalgam	RLM0001
Quartz glass 40 watt	QS0001
Sieve panel 1 x 1147 x 398 x 50mm Ø 40 High Flow	ZH00001

Notes



Discover the complete Basic series

Combi 2 Moving-bed incl. UV-C

Perfect water quality in a simple and reliable way

Filtreau offers high-quality filtration systems and pumps designed for ponds and koi ponds. Our products are developed using extensive expertise, advanced technologies and premium professional materials.



Drum filter

A pre-filter is a drum filter that efficiently removes very fine debris (70 µm / 120 µm) from the water. The water enters the drum filter either pump-fed or gravity-fed, where contaminants are separated from the water. The water flows from the inside of the drum through the filter screen to the outside of the unit. The debris remains on the sieve panel (PE), which is mounted on the drum. The sieve panel (PE) is fitted with a fine stainless steel mesh (70 µm / 120 µm).

The debris is rinsed off the sieve panel (PE) by means of brass or plastic nozzles and collected in the gutter. The cleaning frequency depends on the level of contamination of the pond water.



BASIC LINE

The control box of the Basic series comes standard with:

Automatic cleaning: float switch. **Manual operation:** turn button / rinse. **Drum flushing time:** 10 sec. **Flushing level (gravity-fed):** adjustable. **Flushing level (pump-fed):** not adjustable. **Power outlets:** flushing pump, pond pump, drum drive motor and UVC. **Dry-run protection deactivation:** 30 sec (UVC lamp).

Technical specifications



Product	FILTREAU COMBI-2 GRAVITY (MOVING-BED) INCL. UVC	FILTREAU COMBI-2 GRAVITY (MOVING-BED) INCL. UVC (PUMPFED)
Length x width x height	1005 x 920 x 555mm	1005 x 920 x 555mm
Drum	Ø 400 x 430mm	Ø 400 x 430mm
Mesh size screen (PP) with stainless steel (SS) mesh	120 µm	120 µm
Max. Flow	15 m ³	10 m ³
Max. pond volume	30 m ³	20 m ³
Max. pond volume with koi	15 m ³	10 m ³
Inlet (mm)	2 x 110mm	2 x 110mm
Outlet (mm)	1 x 110mm	1 x 110mm
Internal flushing pump		
Industrial motor	33Nm/40 watt 220/230V	33Nm/40 watt 220/230V
Built-in UVC unit	1 x 40 watt	1 x 40 watt
Air supply	1 x Air stone	1 x Air stone
Control box	including	including
Item no.	COM0020	COM0020PF

Spare parts

Product	Item no.
Replacement lamp UV-C 40 watt amalgam	RLM0001
Quartz glass 40 watt	QS0001
Sieve panel 1 x 1147 x 398 x 50mm Ø 40 120mc	ZS00003

Notes



Discover the complete Basic series

Combi 2 Japanese Mats incl. UV-C

Perfect water quality in a simple and reliable way

Filtreau offers high-quality filtration systems and pumps designed for ponds and koi ponds. Our products are developed using extensive expertise, advanced technologies and premium professional materials.



Drum filter

A pre-filter is a drum filter that efficiently removes very fine debris (70 µm / 120 µm) from the water. The water enters the drum filter either pump-fed or gravity-fed, where contaminants are separated from the water. The water flows from the inside of the drum through the filter screen to the outside of the unit. The debris remains on the sieve panel (PE), which is mounted on the drum. The sieve panel (PE) is fitted with a fine stainless steel mesh (70 µm / 120 µm).

The debris is rinsed off the sieve panel (PE) by means of brass or plastic nozzles and collected in the gutter. The cleaning frequency depends on the level of contamination of the pond water.



BASIC LINE

The control box of the Basic series comes standard with:

Automatic cleaning: float switch. **Manual operation:** turn button / rinse. **Drum flushing time:** 10 sec. **Flushing level (gravity-fed):** adjustable. **Flushing level (pump-fed):** not adjustable. **Power outlets:** flushing pump, pond pump, drum drive motor and UVC. **Dry-run protection deactivation:** 30 sec (UVC lamp).

Technical specifications



Product	FILTREAU COMBI-2 GRAVITY (JAP. MATS) INCL. UVC	FILTREAU COMBI-2 GRAVITY (JAP. MATS) INCL. UVC (PUMPFED)
Length x width x height	1005 x 920 x 555mm	1005 x 920 x 555mm
Drum	Ø 400 x 430mm	Ø 400 x 430mm
Mesh size screen (PP) with stainless steel (SS) mesh	120 µm	120 µm
Max. Flow	15 m ³	10 m ³
Max. pond volume	30 m ³	20 m ³
Max. pond volume with koi	15 m ³	10 m ³
Inlet (mm)	2 x 110mm	2 x 110mm
Outlet (mm)	1 x 110mm	1 x 110mm
Internal flushing pump		
Industrial motor	33Nm/40 watt 220/230V	33Nm/40 watt 220/230V
Built-in UVC unit	1 x 40 watt High-Output	1 x 40 watt High-Output
Air supply	1x Air stone	1x Air stone
Control box	including	including
Item no.	COM0021	COM0021PF

Spare parts

Product	Item no.
Replacement lamp UV-C 40 watt amalgam	RLM0001
Quartz glass 40 watt	QS0001
Sieve panel 1 x 1147 x 398 x 50mm Ø 40 120mc	ZS00003

Notes



Discover the complete Basic series

Combi 2 Moving-bed incl. UV-C en Rinsepump

Perfect water quality in a simple and reliable way

Filtreau offers high-quality filtration systems and pumps designed for ponds and koi ponds. Our products are developed using extensive expertise, advanced technologies and premium professional materials.

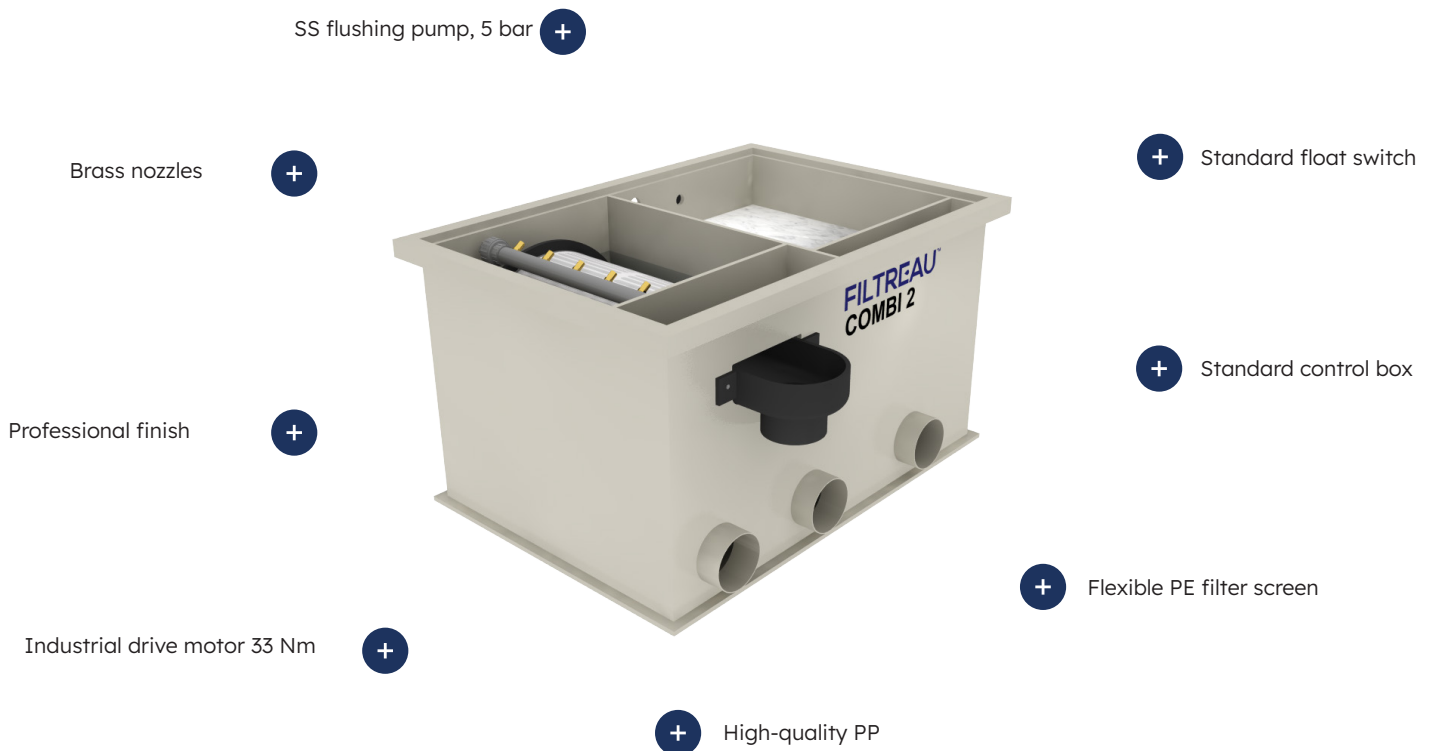

Drum filter

A pre-filter is a drum filter that efficiently removes very fine debris (70 µm / 120 µm) from the water. The water enters the drum filter either pump-fed or gravity-fed, where contaminants are separated from the water. The water flows from the inside of the drum through the filter screen to the outside of the unit. The debris remains on the sieve panel (PE), which is mounted on the drum. The sieve panel (PE) is fitted with a fine stainless steel mesh (70 µm / 120 µm).

The debris is rinsed off the sieve panel (PE) by means of brass or plastic nozzles and collected in the gutter. The cleaning frequency depends on the level of contamination of the pond water.



BASIC LINE

The control box of the Basic series comes standard with:

Automatic cleaning: float switch. **Manual operation:** turn button / rinse. **Drum flushing time:** 10 sec. **Flushing level (gravity-fed):** adjustable. **Flushing level (pump-fed):** not adjustable. **Power outlets:** flushing pump, pond pump, drum drive motor and UVC. **Dry-run protection deactivation:** 30 sec (UVC lamp).

Technical specifications



Product	Filtreau combi-2 gravity (moving-bed) incl. UVC /incl. rinsepump	Filtreau combi-2 pumped (moving-bed) incl. UVC /incl. rinsepump
Length x width x height	1005 x 920 x 555mm	1005 x 920 x 555mm
Drum	Ø 400 x 430mm	Ø 400 x 430mm
Mesh size screen (PP) with stainless steel (SS) mesh	120 µm	120 µm
Max. Flow	15 m ³	10 m ³
Max. pond volume	30 m ³	20 m ³
Max. pond volume with koi	15 m ³	10 m ³
Inlet (mm)	2 x 110mm	2 x 110mm
Outlet (mm)	1 x 110mm	1 x 110mm
Internal flushing pump	SS 5 bar/750 watt 220/230V	SS 5 bar/750 watt 220/230V
Industrial motor	33Nm/40 watt 220/230V	33Nm/40 watt 220/230V
Built-in UVC unit	1x 40 watt amalgam	1x 40 watt amalgam
Air supply	1x Air stone	1x Air stone
Control box	including	including
Item no.	COM0020IN	COM0020PFIN

Spare parts

Product	Item no.
Replacement lamp UV-C 40 watt amalgam	RLM0001
Quartz glass 40 watt	QS0006
Sieve panel 1 x 1147 x 398 x 50mm Ø 40	ZS00005

Notes



Discover the complete Basic series

Combi 2 Jap. Mats incl. UV-C en Rinsepump

Perfect water quality in a simple and reliable way

Filtreau offers high-quality filtration systems and pumps designed for ponds and koi ponds. Our products are developed using extensive expertise, advanced technologies and premium professional materials.

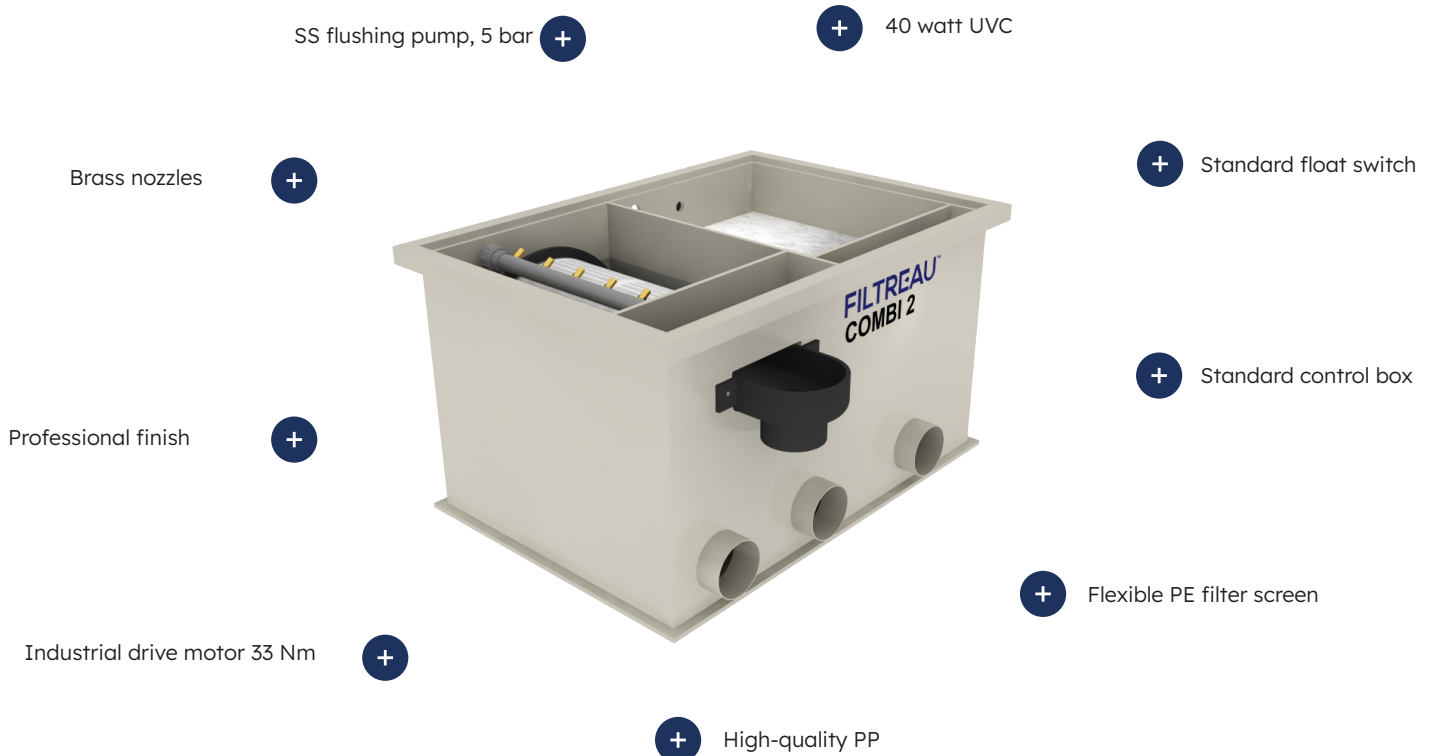

Drum filter

A pre-filter is a drum filter that efficiently removes very fine debris (70 μm / 120 μm) from the water. The water enters the drum filter either pump-fed or gravity-fed, where contaminants are separated from the water. The water flows from the inside of the drum through the filter screen to the outside of the unit. The debris remains on the sieve panel (PE), which is mounted on the drum. The sieve panel (PE) is fitted with a fine stainless steel mesh (70 μm / 120 μm).

The debris is rinsed off the sieve panel (PE) by means of brass or plastic nozzles and collected in the gutter. The cleaning frequency depends on the level of contamination of the pond water.



BASIC LINE

The control box of the Basic series comes standard with:

Automatic cleaning: float switch. **Manual operation:** turn button / rinse. **Drum flushing time:** 10 sec. **Flushing level (gravity-fed):** adjustable. **Flushing level (pump-fed):** not adjustable. **Power outlets:** flushing pump, pond pump, drum drive motor and UVC. **Dry-run protection deactivation:** 30 sec (UVC lamp).

Technical specifications



Product	FILTREAU COMBI-2 GRAVITY (JAP. MATS) INCL. UVC /INCL. RINSEPUMP	FILTREAU COMBI-2 PUMPFED (JAP. MATS) INCL. UVC /INCL. RINSEPUMP
Length x width x height	1005 x 920 x 555mm	1005 x 920 x 555mm
Drum	Ø 400 x 430mm	Ø 400 x 430mm
Mesh size screen (PP) with stainless steel (SS) mesh	120 µm	120 µm
Max. Flow	15 m ³	10 m ³
Max. pond volume	30 m ³	20 m ³
Max. pond volume with koi	15 m ³	15 m ³
Inlet (mm)	2 x 110mm	2 x 110mm
Outlet (mm)	1 x 110mm	1 x 110mm
Internal flushing pump	SS 5 bar/750watt 220/230V	SS 5 bar/750 watt 220/230V
Industrial motor	33Nm/40 watt 220/230V	33Nm/40 watt 220/230V
Built-in UVC unit	1 x 40 watt amalgam	1 x 40 watt amalgam
Air supply	1x Air stone	1x Air stone
Control box	including	including
Item no.	COM0021IN	COM0021PFIN

Spare parts

Product	Item no.
Replacement lamp UV-C 40 watt	RLM0001
Quartz glass 40 watt	QS0001
Sieve panel 1 x 1147 x 398 x 50mm Ø 40 120mc	ZS00005

Notes



Discover the complete Basic series

Combi 2 Moving-bed incl. UV-C

Perfect water quality in a simple and reliable way

Filtreau offers high-quality filtration systems and pumps designed for ponds and koi ponds. Our products are developed using extensive expertise, advanced technologies and premium professional materials.

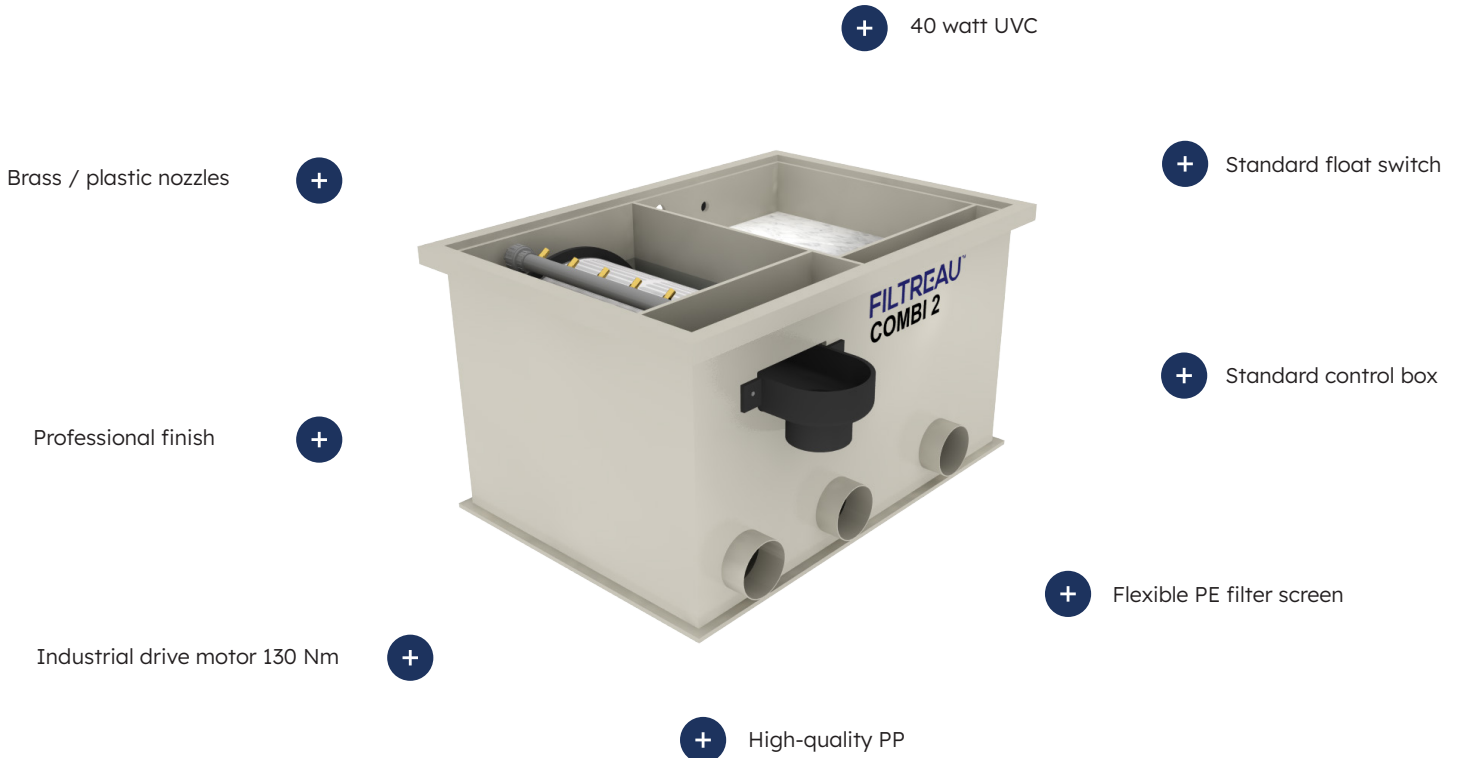

Drum filter

A pre-filter is a drum filter that efficiently removes very fine debris (70 µm / 120 µm) from the water. The water enters the drum filter either pump-fed or gravity-fed, where contaminants are separated from the water. The water flows from the inside of the drum through the filter screen to the outside of the unit. The debris remains on the sieve panel (PE), which is mounted on the drum. The sieve panel (PE) is fitted with a fine stainless steel mesh (70 µm / 120 µm).

The debris is rinsed off the sieve panel (PE) by means of brass or plastic nozzles and collected in the gutter. The cleaning frequency depends on the level of contamination of the pond water.



BASIC LINE

The control box of the Basic series comes standard with:

Automatic cleaning: float switch. **Manual operation:** turn button / rinse. **Drum flushing time:** 10 sec. **Flushing level (gravity-fed):** adjustable. **Flushing level (pump-fed):** not adjustable. **Power outlets:** flushing pump, pond pump, drum drive motor and UVC. **Dry-run protection deactivation:** 30 sec (UVC lamp).

Technical specifications



Product	FILTREAU COMBI-2 SPG XL GRAVITY (MOVING-BED) INCL. UVC	FILTREAU COMBI-2 SPG XL GRAVITY (MOVING-BED) INCL. UVC (PUMPFED)
Length x width x height	1005 x 920 x 555mm	1005 x 920 x 555mm
Drum	Ø 400 x 430mm	Ø 400 x 430mm
Mesh size screen (PP) with stainless steel (SS) mesh	120 µm	120 µm
Max. Flow	15 m ³	10 m ³
Max. pond volume	30 m ³	20 m ³
Max. pond volume with koi	15 m ³	10 m ³
Inlet (mm)	2 x 110mm	2 x 110mm
Outlet (mm)	1 x 110mm	1 x 110mm
Internal flushing pump		
Industrial motor	130Nm/60 watt 220/230V	130Nm/60 watt 220/230V
Built-in UVC unit	1 x 40 watt amalgam	1 x 40 watt amalgam
Air supply	1 x Air stone	1 x Air stone
Control box	including	including
Item no.	COMSP20	COMSP20PF

Spare parts

Product	Item no.
Replacement lamp UV-C 40 watt amalgam	RLM0001
Quartz glass 40 watt	QS0001
Sieve panel 1 x 1147 x 398 x 50mm Ø 40 120mc	ZS00005

Notes



Discover the complete Basic series

Combi 2 Jap. Mats incl. UV-C

Perfect water quality in a simple and reliable way

Filtreau offers high-quality filtration systems and pumps designed for ponds and koi ponds. Our products are developed using extensive expertise, advanced technologies and premium professional materials.

+ 40 watt UVC

Brass nozzles



+ Standard float switch

Professional finish



+ Standard control box

Industrial drive motor 130 Nm



+ Flexible PE filter screen

+ High-quality PP



Drum filter

A pre-filter is a drum filter that efficiently removes very fine debris (70 µm / 120 µm) from the water. The water enters the drum filter either pump-fed or gravity-fed, where contaminants are separated from the water. The water flows from the inside of the drum through the filter screen to the outside of the unit. The debris remains on the sieve panel (PE), which is mounted on the drum. The sieve panel (PE) is fitted with a fine stainless steel mesh (70 µm / 120 µm).

The debris is rinsed off the sieve panel (PE) by means of brass or plastic nozzles and collected in the gutter. The cleaning frequency depends on the level of contamination of the pond water.



BASIC LINE

The control box of the Basic series comes standard with:

Automatic cleaning: float switch. **Manual operation:** turn button / rinse. **Drum flushing time:** 10 sec. **Flushing level (gravity-fed):** adjustable. **Flushing level (pump-fed):** not adjustable. **Power outlets:** flushing pump, pond pump, drum drive motor and UVC. **Dry-run protection deactivation:** 30 sec (UVC lamp).

Technical specifications



Product	FILTREAU COMBI-2 SPG XL GRAVITY (JAP. MATS) INCL. UVC	FILTREAU COMBI-2 SPG XL GRAVITY (JAP. MATS) INCL. UVC (PUMPFED)
Length x width x height	1005 x 920 x 555mm	1005 x 920 x 555mm
Drum	Ø 400 x 430mm	Ø 400 x 430mm
Mesh size screen (PP) with stainless steel (SS) mesh	120 µm	120 µm
Max. Flow	15 m ³	10 m ³
Max. pond volume	30 m ³	20 m ³
Max. pond volume with koi	15 m ³	10 m ³
Inlet (mm)	2 x 110mm	2 x 110mm
Outlet (mm)	1 x 110mm	1 x 110mm
Internal flushing pump		
Industrial motor	130Nm/60 watt 220/230V	130Nm/60 watt 220/230V
Built-in UVC unit	1 x 40 watt amalgam	1 x 40 watt amalgam
Air supply	1x Air stone	1x Air stone
Control box	including	including
Item no.	COMSP21	COMSP21PF

Spare parts

Product	Item no.
Replacement lamp UV-C 40 watt	RLM0001
Quartz glass 40 watt	QS0001
Sieve panel 1 x 1147 x 398 x 50mm Ø 40 120mc	ZS00005

Notes



Discover the complete Basic series

Combi 2 Moving-bed incl. UV-C en Rinsepump

Perfect water quality in a simple and reliable way

Filtreau offers high-quality filtration systems and pumps designed for ponds and koi ponds. Our products are developed using extensive expertise, advanced technologies and premium professional materials.

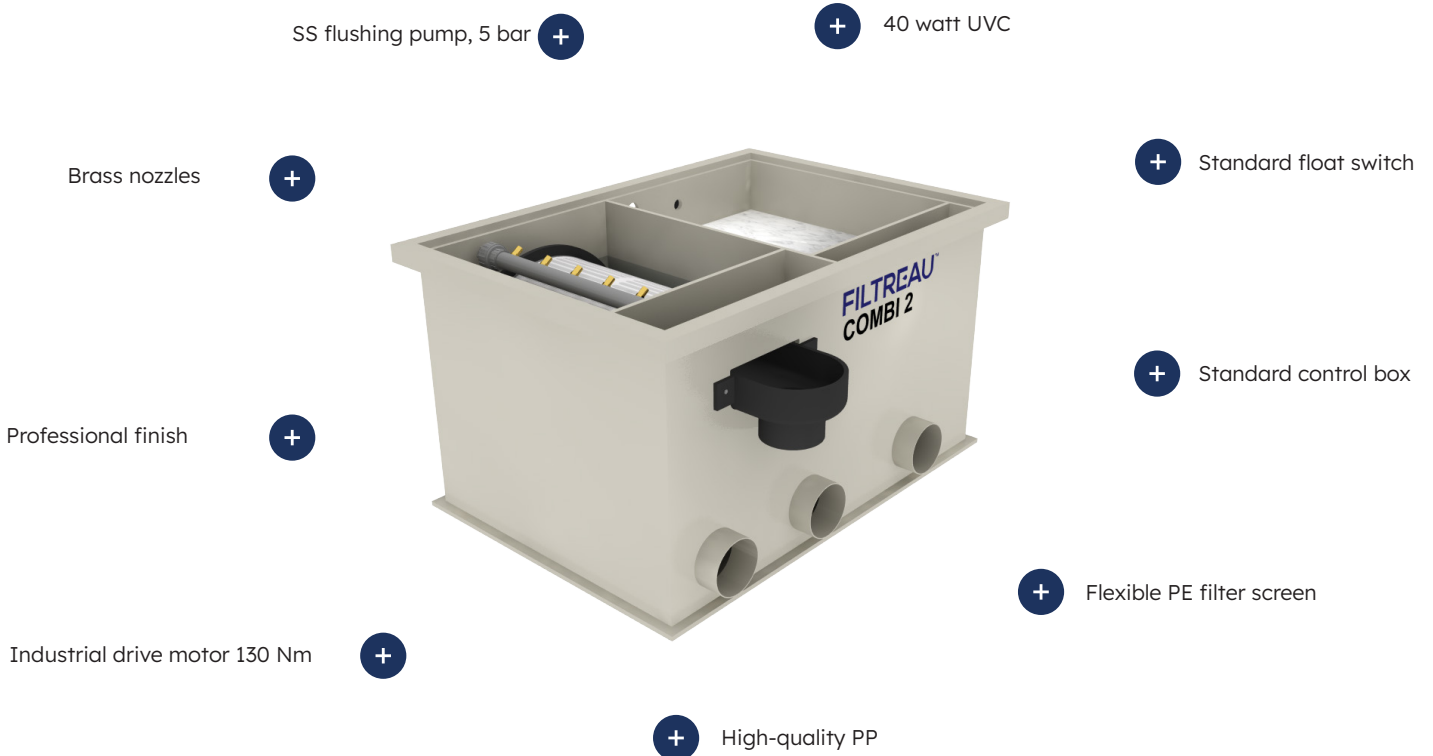

Drum filter

A pre-filter is a drum filter that efficiently removes very fine debris (70 µm / 120 µm) from the water. The water enters the drum filter either pump-fed or gravity-fed, where contaminants are separated from the water. The water flows from the inside of the drum through the filter screen to the outside of the unit. The debris remains on the sieve panel (PE), which is mounted on the drum. The sieve panel (PE) is fitted with a fine stainless steel mesh (70 µm / 120 µm).

The debris is rinsed off the sieve panel (PE) by means of brass or plastic nozzles and collected in the gutter. The cleaning frequency depends on the level of contamination of the pond water.

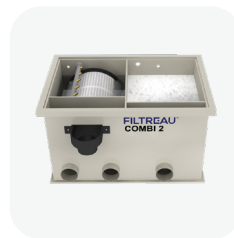

BASIC LINE

The control box of the Basic series comes standard with:

Automatic cleaning: float switch. **Manual operation:** turn button / rinse. **Drum flushing time:** 10 sec. **Flushing level (gravity-fed):** adjustable. **Flushing level (pump-fed):** not adjustable. **Power outlets:** flushing pump, pond pump, drum drive motor and UVC. **Dry-run protection deactivation:** 30 sec (UVC lamp).

Technical specifications



Product	FILTREAU COMBI-2 SPG XL PUMPFED (MOVING-BED) INCL. UVC /INCL. RINSEPUMP	FILTREAU COMBI-2 SPG XL GRAVITY (MOVING-BED) INCL. UVC /INCL. RINSEPUMP
Length x width x height	1005 x 920 x 555mm	1005 x 920 x 555mm
Drum	Ø 400 x 430mm	Ø 400 x 430mm
Mesh size screen (PP) with stainless steel (SS) mesh	120 µm	120 µm
Max. Flow	10 m ³	15 m ³
Max. pond volume	20 m ³	30 m ³
Max. pond volume with koi	10 m ³	15 m ³
Inlet (mm)	2 x 110mm	2 x 110mm
Outlet (mm)	1 x 110mm	1 x 110mm
Internal flushing pump	SS 5 bar/750 watt 220/230V	SS 5 bar/750 watt 220/230V
Industrial motor	130Nm/60 watt 220/230V	130Nm/60 watt 220/230V
Built-in UVC unit	1 x 40 watt amalgam	1 x 40 watt amalgam
Air supply	1x Air stone	1x Air stone
Control box	including	including
Item no.	COMSP20PFIN	COMSP20IN

Spare parts

Product	Item no.
Replacement lamp UV-C 40 watt amalgam	RLM0001
Quartz glass 40 watt	QS0001
Sieve panel 1 x 1147 x 398 x 50mm Ø 40 120mc	ZS00005

Notes



Discover the complete Basic series

Drum 50XL incl. UV-C

Perfect water quality in a simple and reliable way

Filtreau offers high-quality filtration systems and pumps designed for ponds and koi ponds. Our products are developed using extensive expertise, advanced technologies and premium professional materials.

+ 40 watt 2x amalgam UV-C

Brass nozzles



+ Standard float switch

Professional finish



+ Standard control box

Industrial drive motor 130 Nm



+ Flexible PE filter screen

+ High-quality PP



Drum filter

A pre-filter is a drum filter that efficiently removes very fine debris (70 µm / 120 µm) from the water. The water enters the drum filter either pump-fed or gravity-fed, where contaminants are separated from the water. The water flows from the inside of the drum through the filter screen to the outside of the unit. The debris remains on the sieve panel (PE), which is mounted on the drum. The sieve panel (PE) is fitted with a fine stainless steel mesh (70 µm / 120 µm).

The debris is rinsed off the sieve panel (PE) by means of brass or plastic nozzles and collected in the gutter. The cleaning frequency depends on the level of contamination of the pond water.

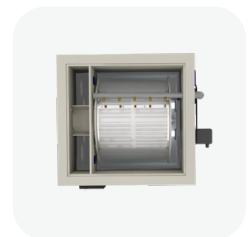

BASIC LINE

The control box of the Basic series comes standard with:

Automatic cleaning: float switch. **Manual operation:** turn button / rinse. **Drum flushing time:** 10 sec. **Flushing level (gravity-fed):** adjustable. **Flushing level (pump-fed):** not adjustable. **Power outlets:** flushing pump, pond pump, drum drive motor and UVC. **Dry-run protection deactivation:** 30 sec (UVC lamp).

Technical specifications



Product	50XL DRUM GRAVITY INCL. 2X UV-C SPG XL	50XL DRUM PUMP-FED INCL. 2X UV-C SPG XL
Length x width x height	710 x 790 x 790mm	710 x 790 x 790mm
Drum	Ø 520 x 420mm	Ø 520 x 420mm
Mesh size screen (PP) with stainless steel (SS) mesh	120 µm	120 µm
Max. Flow	40 m ³	30 m ³
Max. pond volume	80 m ³	60 m ³
Max. pond volume with koi	40 m ³	30 m ³
Inlet (mm)	4 x 110mm	4 x 110mm
Outlet (mm)	3 x 110mm	3 x 110mm
Internal flushing pump		
Industrial motor	130Nm/60 watt 220/230V	130Nm/60 watt 220/230V
Built-in UVC unit	2 x 40 watt amalgam	2 x 40 watt amalgam
Air supply	1 x Air stone 35cm	1 x Air stone 35cm
Control box	including	including
Item no.	TR00013	TR00014

Spare parts

Product	Item no.
Replacement lamp UV-C 40 watt amalgam	RLM0001
Quartz glass 40 watt	QS0001
Sieve panel 1 x 757 x 398 x 5 120 mc	ZH00005

Notes



Discover the complete Basic series

Combi-Next incl. UV-C

Perfect water quality in a simple and reliable way

Filtreau offers high-quality filtration systems and pumps designed for ponds and koi ponds. Our products are developed using extensive expertise, advanced technologies and premium professional materials.

+ 40 watt UV-C

Brass nozzles



+ Standard float switch

+ Standard control box

Professional finish



+ Flexible PE filter screen

Industrial drive motor 33 Nm



+ High-quality PP



Drum filter

A pre-filter is a drum filter that efficiently removes very fine debris (70 µm / 120 µm) from the water. The water enters the drum filter either pump-fed or gravity-fed, where contaminants are separated from the water. The water flows from the inside of the drum through the filter screen to the outside of the unit. The debris remains on the sieve panel (PE), which is mounted on the drum. The sieve panel (PE) is fitted with a fine stainless steel mesh (70 µm / 120 µm).

The debris is rinsed off the sieve panel (PE) by means of brass or plastic nozzles and collected in the gutter. The cleaning frequency depends on the level of contamination of the pond water.

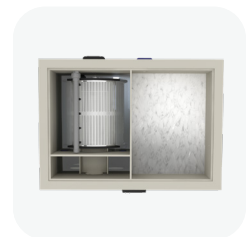

BASIC LINE

The control box of the Basic series comes standard with:

Automatic cleaning: float switch. **Manual operation:** turn button / rinse. **Drum flushing time:** 10 sec. **Flushing level (gravity-fed):** adjustable. **Flushing level (pump-fed):** not adjustable. **Power outlets:** flushing pump, pond pump, drum drive motor and UVC. **Dry-run protection deactivation:** 30 sec (UVC lamp).

Technical specifications



Product	FILTREAU COMBI-NEXT INCL. UVC (GRAVITY) PP	FILTREAU COMBI-NEXT INCL. UVC (PUMP-FED) PP
Length x width x height	1040 x 920 x 1020mm	1040 x 920 x 1020mm
Drum	Ø 400 x 430mm	Ø 400 x 430mm
Mesh size screen (PP) with stainless steel (SS) mesh	70 µm	70 µm
Max. Flow	30 m ³	20 m ³
Max. pond volume	60 m ³	40 m ³
Max. pond volume with koi	30 m ³	20 m ³
Inlet (mm)	3 x 110mm	3 x 110mm
Outlet (mm)	2 x 110mm	2 x 110mm
Internal flushing pump		
Industrial motor	33Nm/40 watt 220/230V	33Nm/40 watt 220/230V
Built-in UVC unit	1 x 40 watt amalgam	1 x 40 watt amalgam
Air supply	1x Disc 9"	1x Disc 9"
Control box	including	including
Item no.	COM0002	COM0002PF

Spare parts

Product	Item no.
Replacement lamp UV-C 40 watt amalgam	RLM0001
Quartz glass 40 watt	QS0001
Sieve panel 1 x 1147 x 398 x 50mm Ø 40	ZS00001

Notes



Discover the complete Basic series

Combi-Next incl. UV-C en Rinsepump

Perfect water quality in a simple and reliable way

Filtreau offers high-quality filtration systems and pumps designed for ponds and koi ponds. Our products are developed using extensive expertise, advanced technologies and premium professional materials.



Drum filter

A pre-filter is a drum filter that efficiently removes very fine debris (70 µm / 120 µm) from the water. The water enters the drum filter either pump-fed or gravity-fed, where contaminants are separated from the water. The water flows from the inside of the drum through the filter screen to the outside of the unit. The debris remains on the sieve panel (PE), which is mounted on the drum. The sieve panel (PE) is fitted with a fine stainless steel mesh (70 µm / 120 µm).

The debris is rinsed off the sieve panel (PE) by means of brass or plastic nozzles and collected in the gutter. The cleaning frequency depends on the level of contamination of the pond water.



BASIC LINE

The control box of the Basic series comes standard with:

Automatic cleaning: float switch. **Manual operation:** turn button / rinse. **Drum flushing time:** 10 sec. **Flushing level (gravity-fed):** adjustable. **Flushing level (pump-fed):** not adjustable. **Power outlets:** flushing pump, pond pump, drum drive motor and UVC. **Dry-run protection deactivation:** 30 sec (UVC lamp).

Technical specifications



Product	FILTREAU COMBI-NEXT INCL. UVC (GRAVITY) PP INCL. RINSEPUMP	FILTREAU COMBI-NEXT INCL. UVC (PUMP-FED) PP INCL. RINSEPUMP
Length x width x height	1040 x 920 x 1020mm	1040 x 920 x 1020mm
Drum	Ø 400 x 430mm	Ø 400 x 430mm
Mesh size screen (PP) with stainless steel (SS) mesh	70 µm	70 µm
Max. Flow	30 m ³	20 m ³
Max. pond volume	60 m ³	40 m ³
Max. pond volume with koi	30 m ³	20 m ³
Inlet (mm)	3 x 110mm	3 x 110mm
Outlet (mm)	2 x 110mm	2 x 110mm
Internal flushing pump	SS 5 bar/750 watt 220/230V	SS 5 bar/750 watt 220/230V
Industrial motor	33Nm/40 watt 220/230V	33Nm/40 watt 220/230V
Built-in UVC unit	1 x 40 watt amalgam	1 x 40 watt amalgam
Air supply	1x Disc 9"	1 x Disc 9"
Control box	including	including
Item no.	COM0002IN	COM0002PFIN

Spare parts

Product	Item no.
Replacement lamp UV-C 40 watt	RLM0001
Quartz glass 40 watt	QS0001
Sieve panel 1 x 1147 x 398 x 50mm Ø 40 70mc	ZS00001

Notes



Discover the complete Basic series

Combi Next incl. UV-C

Perfect water quality in a simple and reliable way

Filtreau offers high-quality filtration systems and pumps designed for ponds and koi ponds. Our products are developed using extensive expertise, advanced technologies and premium professional materials.



Drum filter

A pre-filter is a drum filter that efficiently removes very fine debris (70 µm / 120 µm) from the water. The water enters the drum filter either pump-fed or gravity-fed, where contaminants are separated from the water. The water flows from the inside of the drum through the filter screen to the outside of the unit. The debris remains on the sieve panel (PE), which is mounted on the drum. The sieve panel (PE) is fitted with a fine stainless steel mesh (70 µm / 120 µm).

The debris is rinsed off the sieve panel (PE) by means of brass or plastic nozzles and collected in the gutter. The cleaning frequency depends on the level of contamination of the pond water.



BASIC LINE

The control box of the Basic series comes standard with:

Automatic cleaning: float switch. **Manual operation:** turn button / rinse. **Drum flushing time:** 10 sec. **Flushing level (gravity-fed):** adjustable. **Flushing level (pump-fed):** not adjustable. **Power outlets:** flushing pump, pond pump, drum drive motor and UVC. **Dry-run protection deactivation:** 30 sec (UVC lamp).

Technical specifications



Product	FILTREAU COMBI-NEXT INCL. UVC (GRAVITY) SPG XL MOTOR	FILTREAU COMBI-NEXT INCL. UVC (PUMP-FED) SPG XL MOTOR
Length x width x height	1040 x 920 x 1020mm	1040 x 920 x 1020mm
Drum	Ø 400 x 430mm	Ø 400 x 430mm
Mesh size screen (PP) with stainless steel (SS) mesh	70 µm	70 µm
Max. Flow	30 m ³	20 m ³
Max. pond volume	60 m ³	40 m ³
Max. pond volume with koi	30 m ³	20 m ³
Inlet (mm)	3 x 110mm	3 x 110mm
Outlet (mm)	2 x 110mm	2 x 110mm
Internal flushing pump		
Industrial motor	130Nm/60 watt 220/230V	130Nm/60 watt 220/230V
Built-in UVC unit	1 x 40 watt amalgam	1 x 40 watt amalgam
Air supply	1x Disc 9"	1x Disc 9"
Control box	including	including
Item no.	COMSP02	COMSP02PF

Spare parts

Product	Item no.
Replacement lamp UV-C 40 watt amalgam	RLM0001
Quartz glass 40 watt	QS0001
Sieve panel 1 x 1147 x 398 x 50mm Ø 40	ZS00001

Notes



Discover the complete Basic series

Combi Next incl. UV-C en Rinsepump

Perfect water quality in a simple and reliable way

Filtreau offers high-quality filtration systems and pumps designed for ponds and koi ponds. Our products are developed using extensive expertise, advanced technologies and premium professional materials.



Drum filter

A pre-filter is a drum filter that efficiently removes very fine debris (70 µm / 120 µm) from the water. The water enters the drum filter either pump-fed or gravity-fed, where contaminants are separated from the water. The water flows from the inside of the drum through the filter screen to the outside of the unit. The debris remains on the sieve panel (PE), which is mounted on the drum. The sieve panel (PE) is fitted with a fine stainless steel mesh (70 µm / 120 µm).

The debris is rinsed off the sieve panel (PE) by means of brass or plastic nozzles and collected in the gutter. The cleaning frequency depends on the level of contamination of the pond water.



BASIC LINE

The control box of the Basic series comes standard with:

Automatic cleaning: float switch. **Manual operation:** turn button / rinse. **Drum flushing time:** 10 sec. **Flushing level (gravity-fed):** adjustable. **Flushing level (pump-fed):** not adjustable. **Power outlets:** flushing pump, pond pump, drum drive motor and UVC. **Dry-run protection deactivation:** 30 sec (UVC lamp).

Technical specifications



Product	FILTREAU COMBI-NEXT INCL. UVC (GRAVITY) SPG XL MOTOR INCL. RINSEPUMP	FILTREAU COMBI-NEXT INCL. UVC (PUMP-FED) SPG XL MOTOR INCL. RINSEPUMP
Length x width x height	1040 x 920 x 1020mm	1040 x 920 x 1020mm
Drum	Ø 400 x 430mm	Ø 400 x 430mm
Mesh size screen (PP) with stainless steel (SS) mesh	70 µm	70 µm
Max. Flow	30 m ³	20 m ³
Max. pond volume	60 m ³	40 m ³
Max. pond volume with koi	20 m ³	20 m ³
Inlet (mm)	3 x 110mm	3 x 110mm
Outlet (mm)	2 x 110mm	2 x 110mm
Internal flushing pump	SS 5 bar/750 watt 220/230V	SS 5 bar/750 watt 220/230V
Industrial motor	130Nm/60 watt 220/230V	130Nm/60 watt 220/230V
Built-in UVC unit	1 x 40 watt amalgam	1 x 40 watt amalgam
Air supply	1x Disc 9"	1x Disc 9"
Control box	including	including
Item no.	COMSP02IN	COMSP02PFIN

Spare parts

Product	Item no.
Replacement lamp UV-C 40 watt amalgam	RLM0001
Quartz glass 40 watt	QS0001
Sieve panel 1 x 1147 x 398 x 50mm Ø 40	ZS00001

Notes



Discover the complete Basic series

Combi 50XL incl. Rinsepump en incl. 2x UV-C

Perfect water quality in a simple and reliable way

Filtreau offers high-quality filtration systems and pumps designed for ponds and koi ponds. Our products are developed using extensive expertise, advanced technologies and premium professional materials.



Drum filter

A pre-filter is a drum filter that efficiently removes very fine debris (70 µm / 120 µm) from the water. The water enters the drum filter either pump-fed or gravity-fed, where contaminants are separated from the water. The water flows from the inside of the drum through the filter screen to the outside of the unit. The debris remains on the sieve panel (PE), which is mounted on the drum. The sieve panel (PE) is fitted with a fine stainless steel mesh (70 µm / 120 µm).

The debris is rinsed off the sieve panel (PE) by means of brass or plastic nozzles and collected in the gutter. The cleaning frequency depends on the level of contamination of the pond water.



BASIC LINE

The control box of the Basic series comes standard with:

Automatic cleaning: float switch. **Manual operation:** turn button / rinse. **Drum flushing time:** 10 sec. **Flushing level (gravity-fed):** adjustable. **Flushing level (pump-fed):** not adjustable. **Power outlets:** flushing pump, pond pump, drum drive motor and UVC. **Dry-run protection deactivation:** 30 sec (UVC lamp).

Technical specifications



Product	COMBI 50XL GRAVITY/ INCL. RINSEPUMP INCL. 2X UV-C	COMBI 50XL PUMP-FED / INCL. RINSEPUMP INCL. 2X UV-C
Length x width x height	1270 x 900 x 1030mm	1270 x 900 x 1030mm
Drum	Ø 520 x 420mm	Ø 520 x 420mm
Mesh size screen (PP) with stainless steel (SS) mesh	120 µm	120 µm
Max. Flow	40 m ³	30 m ³
Max. pond volume	80 m ³	60 m ³
Max. pond volume with koi	40 m ³	30 m ³
Inlet (mm)	4 x 110mm	4 x 110mm
Outlet (mm)	3 x 110mm	3 x 110mm
Internal flushing pump	SS 5 bar/750 watt 220/230V	SS 5 bar/750 watt 220/230V
Industrial motor	130Nm/40 watt 220/230V	130Nm/40 watt 220/230V
Built-in UVC unit	2 x 40 watt amalgam	2 x 40 watt amalgam
Air supply	1x Disc 9"	1x Disc 9"
Control box	including	including
Item no.	COM0050IN	COM0050PFIN

Spare parts

Product	Item no.
Replacement lamp UV-C 40 watt amalgam	RLM0001
Quartz glass 40 watt	QS0001
Sieve panel 1 x 757 x 398 x 50mm Ø 40	ZH00005

Notes



Discover the complete Basic series

Combi-After incl. UVC

Perfect water quality in a simple and reliable way

Filtreau offers high-quality filtration systems and pumps designed for ponds and koi ponds. Our products are developed using extensive expertise, advanced technologies and premium professional materials.

+ 40 watt UV-C

Brass nozzles



+ Stainless steel floater

+ Standard control box

Professional finish



+ Flexible PE filter screen

Industrial drive motor 33 Nm



+ High-quality PP



Drum filter

A pre-filter is a drum filter that efficiently removes very fine debris (70 µm / 120 µm) from the water. The water enters the drum filter either pump-fed or gravity-fed, where contaminants are separated from the water. The water flows from the inside of the drum through the filter screen to the outside of the unit. The debris remains on the sieve panel (PE), which is mounted on the drum. The sieve panel (PE) is fitted with a fine stainless steel mesh (70 µm / 120 µm).

The debris is rinsed off the sieve panel (PE) by means of brass or plastic nozzles and collected in the gutter. The cleaning frequency depends on the level of contamination of the pond water.



BASIC LINE

The control box of the Basic series comes standard with:

Automatic cleaning: float switch. **Manual operation:** turn button / rinse. **Drum flushing time:** 10 sec. **Flushing level (gravity-fed):** adjustable. **Flushing level (pump-fed):** not adjustable. **Power outlets:** flushing pump, pond pump, drum drive motor and UVC. **Dry-run protection deactivation:** 30 sec (UVC lamp).

Technical specifications



Product	FILTREAU COMBI-AFTER INCL. UVC (GRAVITY)	FILTREAU COMBI-AFTER INCL. UVC (PUMPFED)
Length x width x height	1730 x 570 x 1020mm	1730 x 570 x 1020mm
Drum	Ø 400 x 430mm	Ø 400 x 430mm
Mesh size screen (PP) with stainless steel (SS) mesh	120 µm	120 µm
Max. Flow	30 m ³	25 m ³
Max. pond volume	60 m ³	50 m ³
Max. pond volume with koi	30 m ³	25 m ³
Inlet (mm)	3 x 110mm	3 x 110mm
Outlet (mm)	3 x 110mm	3 x 110mm
Internal flushing pump		
Industrial motor	33Nm/40 watt 220/230V	33Nm/40 watt 220/230V
Built-in UVC unit	1x 40 watt amalgam	1x 40 watt amalgam
Air supply	1x Disc 9"	1x Disc 9"
Control box	including	including
Item no.	COM0003	COM0003PF

Spare parts

Product	Item no.
Replacement lamp UV-C 40 watt amalgam	RLM0001
Quartz glass 40 watt	QS0001
Sieve panel 1 x 1147 x 398 x 50mm	ZH00003

Notes



Discover the complete Basic series

Combi-After incl. UV-C en Rinsepump

Perfect water quality in a simple and reliable way

Filtreau offers high-quality filtration systems and pumps designed for ponds and koi ponds. Our products are developed using extensive expertise, advanced technologies and premium professional materials.



Drum filter

A pre-filter is a drum filter that efficiently removes very fine debris (70 µm / 120 µm) from the water. The water enters the drum filter either pump-fed or gravity-fed, where contaminants are separated from the water. The water flows from the inside of the drum through the filter screen to the outside of the unit. The debris remains on the sieve panel (PE), which is mounted on the drum. The sieve panel (PE) is fitted with a fine stainless steel mesh (70 µm / 120 µm).

The debris is rinsed off the sieve panel (PE) by means of brass or plastic nozzles and collected in the gutter. The cleaning frequency depends on the level of contamination of the pond water.



BASIC LINE

The control box of the Basic series comes standard with:

Automatic cleaning: float switch. **Manual operation:** turn button / rinse. **Drum flushing time:** 10 sec. **Flushing level (gravity-fed):** adjustable. **Flushing level (pump-fed):** not adjustable. **Power outlets:** flushing pump, pond pump, drum drive motor and UVC. **Dry-run protection deactivation:** 30 sec (UVC lamp).

Technical specifications



Product	FILTREAU COMBI-AFTER INCL. UVC (GRAVITY) INCL. RINSEPUMP	FILTREAU COMBI-AFTER INCL. UVC (PUMPFED) INCL. RINSEPUMP
Length x width x height	1730 x 570 x 1020mm	1730 x 570 x 1020mm
Drum	Ø 400 x 430mm	Ø 400 x 430mm
Mesh size screen (PP) with stainless steel (SS) mesh	120 µm	120 µm
Max. Flow	30 m ³	25 m ³
Max. pond volume	60 m ³	50 m ³
Max. pond volume with koi	30 m ³	25 m ³
Inlet (mm)	3 x 110mm	3 x 110mm
Outlet (mm)	3 x 110mm	3 x 110mm
Internal flushing pump	SS 5 bar/750 watt 220/230V	SS 5 bar/750 watt 220/230V
Industrial motor	33Nm/40 watt 220/230V	33Nm/40 watt 220/230V
Built-in UVC unit	1 x 40 watt amalgam	1 x 40 watt amalgam
Air supply	1x Disc 9"	1x Disc 9"
Control box	including	including
Item no.	COM0003IN	COM0003PFIN

Spare parts

Product	Item no.
Replacement lamp UV-C 40 watt amalgam	RLM0001
Quartz glass 40 watt	QS0001
Sieve panel 1 x 1147 x 398 x 50mm	ZH00003

Notes



Discover the complete Basic series

Rotate Biofilter

Perfect water quality in a simple and reliable way

Filtreau offers high-quality filtration systems and pumps designed for ponds and koi ponds. Our products are developed using extensive expertise, advanced technologies and premium professional materials.



Drum filter

A pre-filter is a drum filter that efficiently removes very fine debris (70 μm / 120 μm) from the water. The water enters the drum filter either pump-fed or gravity-fed, where contaminants are separated from the water. The water flows from the inside of the drum through the filter screen to the outside of the unit. The debris remains on the sieve panel (PE), which is mounted on the drum. The sieve panel (PE) is fitted with a fine stainless steel mesh (70 μm / 120 μm).

The debris is rinsed off the sieve panel (PE) by means of brass or plastic nozzles and collected in the gutter. The cleaning frequency depends on the level of contamination of the pond water.



BASIC LINE

The control box of the Basic series comes standard with:

Automatic cleaning: float switch. **Manual operation:** turn button / rinse. **Drum flushing time:** 10 sec. **Flushing level (gravity-fed):** adjustable. **Flushing level (pump-fed):** not adjustable. **Power outlets:** flushing pump, pond pump, drum drive motor and UVC. **Dry-run protection deactivation:** 30 sec (UVC lamp).

Technical specifications



Product	ROTATE BIOFILTER GRAVITY INCL. 2X UV-C 2X SPG XL	ROTATE BIOFILTER PUMP-FED INCL. 2X UV-C 2X SPG XL
Length x width x height	1430 x 930 x 750mm	1430 x 930 x 750mm
Drum	Ø 520 x 420mm / Ø 540 x 540mm	Ø 520 x 420mm / Ø 540 x 540mm
Mesh size screen (PP) with stainless steel (SS) mesh	120 µm	120 µm
Max. Flow	50 m ³	35 m ³
Max. pond volume	100 m ³	70 m ³
Max. pond volume with koi	50 m ³	35 m ³
Inlet (mm)	4 x 110mm	4 x 110mm
Outlet (mm)	3 x 110mm	3 x 110mm
Internal flushing pump	SS 5 bar/750 watt 220/230V	SS 5 bar/750 watt 220/230V
Industrial motor	2x 130Nm/60 watt 220/230V	2x 130Nm/60 watt 220/230V
Built-in UVC unit	2 x 40 watt amalgam	2 x 40 watt amalgam
Air supply	Airstone	Airstone
Control box	including	including
Item no.	RO00001IN	RO00001PFIN

Spare parts

Product	Item no.
Replacement lamp UV-C 40 watt	RLM0001
Quartz glass 40 watt	QS0001
Sieve panel 757 x 398 x 50 High Flow	ZH00005

Notes

Perforated stainless steel (SS) 304 for biodrum



Discover the complete Basic series

PF20 Combi-filter

Perfect water quality in a simple and reliable way

Filtreau offers high-quality filtration systems and pumps designed for ponds and koi ponds. Our products are developed using extensive expertise, advanced technologies and premium professional materials.

Plastic nozzles



Professional finish



Industrial drive motor 33 Nm



Standard float switch



Standard control box



Flexible PE filter screen



High-quality PP



Drum filter

A pre-filter is a drum filter that efficiently removes very fine debris (70 µm / 120 µm) from the water. The water enters the drum filter either pump-fed or gravity-fed, where contaminants are separated from the water. The water flows from the inside of the drum through the filter screen to the outside of the unit. The debris remains on the sieve panel (PE), which is mounted on the drum. The sieve panel (PE) is fitted with a fine stainless steel mesh (70 µm / 120 µm).

The debris is rinsed off the sieve panel (PE) by means of brass or plastic nozzles and collected in the gutter. The cleaning frequency depends on the level of contamination of the pond water.

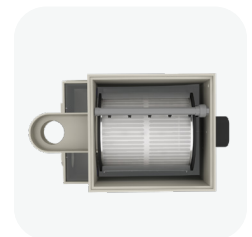

BASIC LINE

The control box of the Basic series comes standard with:

Automatic cleaning: float switch. **Manual operation:** turn button / rinse. **Drum flushing time:** 10 sec. **Flushing level (gravity-fed):** adjustable. **Flushing level (pump-fed):** not adjustable. **Power outlets:** flushing pump, pond pump, drum drive motor and UVC. **Dry-run protection deactivation:** 30 sec (UVC lamp).

Technical specifications



Product	FILTREAU PF20 COMBI-FILTER (PUMP-FED) PP
Length x width x height	890 x 460 x 515mm
Drum	Ø 400 x 430mm
Mesh size screen (PP) with stainless steel (SS) mesh	70 µm
Max. Flow	20 m ³
Max. pond volume	40 m ³
Max. pond volume with koi	20 m ³
Inlet (mm)	1 x 110mm
Outlet (mm)	2 x 110mm
Internal flushing pump	
Industrial motor	33Nm/40 watt 220/230V
Built-in UVC unit	
Air supply	1x Disc 9"
Control box	including
Item no.	COM0001

Spare parts

Product	Item no.
Sieve panel 1 x 1147 x 398 x 50mm Ø 40 120mc	ZH00001

Notes



Discover the complete Basic series

Moving-bed filter

Moving bed

A moving bed filter is commonly used as a biological pond filter. By filling the moving bed filter with Hel-X, effective biological filtration is achieved. Ammonia, nitrite and other harmful substances are converted into less harmful compounds (nitrate), resulting in a healthy biological balance in the pond.

Professional finish

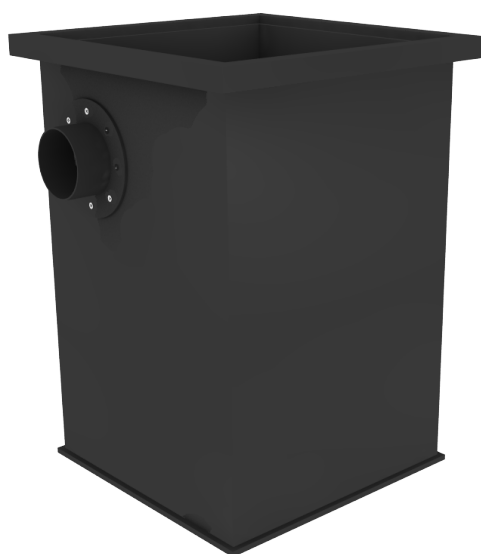

HPDE material

Compared to other pond filters, a moving bed filter offers the advantage of no pressure loss, allowing the use of energy-efficient pond pumps. The filter media is lightweight and compact, weighing only 10–12 kg per 100 liters of Hel-X. This allows a large amount of beneficial bacteria to attach to the media. These bacteria are essential for the rapid breakdown of harmful substances such as ammonia and nitrite.

How does a moving bed filter operate?

A moving bed filter uses an air pump to keep the pond water in motion, allowing beneficial bacteria to easily attach to the filter media and multiply rapidly. Due to continuous aeration, no additional debris can adhere to the filter media.

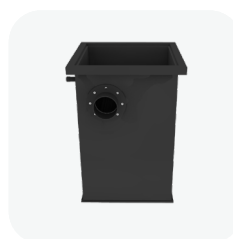

BASIC LINE

The control box of the Basic series comes standard with:

Automatic cleaning: float switch. **Manual operation:** turn button / rinse. **Drum flushing time:** 10 sec. **Flushing level (gravity-fed):** adjustable. **Flushing level (pump-fed):** not adjustable. **Power outlets:** flushing pump, pond pump, drum drive motor and UVC. **Dry-run protection deactivation:** 30 sec (UVC lamp).

Technical specifications



Product	FILTREAU MOVING-BED FILTER 190L PE
Length x width x height	550 x 550 x 750mm
Drum	
Mesh size screen (PP) with stainless steel (SS) mesh	
Max. Flow	20 M3
Max. pond volume	
Max. pond volume with koi	
Inlet (mm)	1 x 110mm
Outlet (mm)	1 x 110mm
Internal flushing pump	
Industrial motor	
Built-in UVC unit	
Air supply	1x Disc 9"
Control box	
Item no.	BB00001

Notes



Discover the complete Basic series

Trickle filter waterfall

Perfect water quality in a simple and reliable way

Filtreau offers high-quality filtration systems and pumps designed for ponds and koi ponds. Our products are developed using extensive expertise, advanced technologies and premium-grade materials.



Trickle filter

Trickle filters effectively convert harmful dissolved waste substances (nitrite, proteins, ammonium, etc.) in the pond water into harmless compounds. The water first enters the inlet chamber at the top, where it is then distributed over the grids.

Below this, the elements are placed, also equipped with grids that allow the water to flow through easily. The elements can be filled with the desired filter media. This ensures optimal oxygen saturation of the water. Due to the high oxygen levels, the risk of oxygen deficiency in the pond is significantly reduced, even during warmer periods.

The trickle filters can be installed separately next to or on the edge of a pond. This facilitates the integration of a trickle filter in combination with our combi drum filters. The trickle filter is available with a waterfall or with three 110 mm outlets.



BASIC LINE

The control box of the Basic series comes standard with:

Automatic cleaning: float switch. **Manual operation:** turn button / rinse. **Drum flushing time:** 10 sec. **Flushing level (gravity-fed):** adjustable. **Flushing level (pump-fed):** not adjustable. **Power outlets:** flushing pump, pond pump, drum drive motor and UVC. **Dry-run protection deactivation:** 30 sec (UVC lamp).

Technical specifications



Product	TRICKLE FILTER WATERFALL	TRICKLE FILTER 110 MM OUTLET
Length x width x height	935 x 460 x 1170mm	935 x 460 x 1170mm
Drum		
Mesh size screen (PP) with stainless steel (SS) mesh		
Max. Flow		
Max. pond volume	20 m ³	20 m ³
Max. pond volume with koi		
Inlet (mm)	1 x 63mm 2"	1 x waterval
Outlet (mm)	1 x 63mm 2"	3 x 110mm
Internal flushing pump		
Industrial motor		
Built-in UVC unit		
Air supply		
Control box		
Item no.	TRI0001	TRI00002

Notes



Discover the complete Basic series

Installation of drum filter in a pump-fed system

In a pump-fed drum filter setup, the pond pump is placed on the bottom of the pond. The drum filter is always installed above the pond water level.

The advantage of a pump-fed system is that it is easy to connect to an existing pond. The pond pump is installed in the deepest part of the pond, where it pumps the (contaminated) pond water through a hose to the drum filter.



Installation of drum filter in a gravity-fed system

In a gravity-fed drum filter setup, the drum filter is supplied by skimmers and bottom drains from the pond. The pond pump is installed outside the pond. In a gravity-fed system, the drum filter is installed approximately 14 cm above the pond water level.

The advantage of a gravity-fed system is that the contaminated pond water is filtered before it reaches the pond pump and is then returned to the pond. Debris present in the pond water is removed by the drum filter during this process.

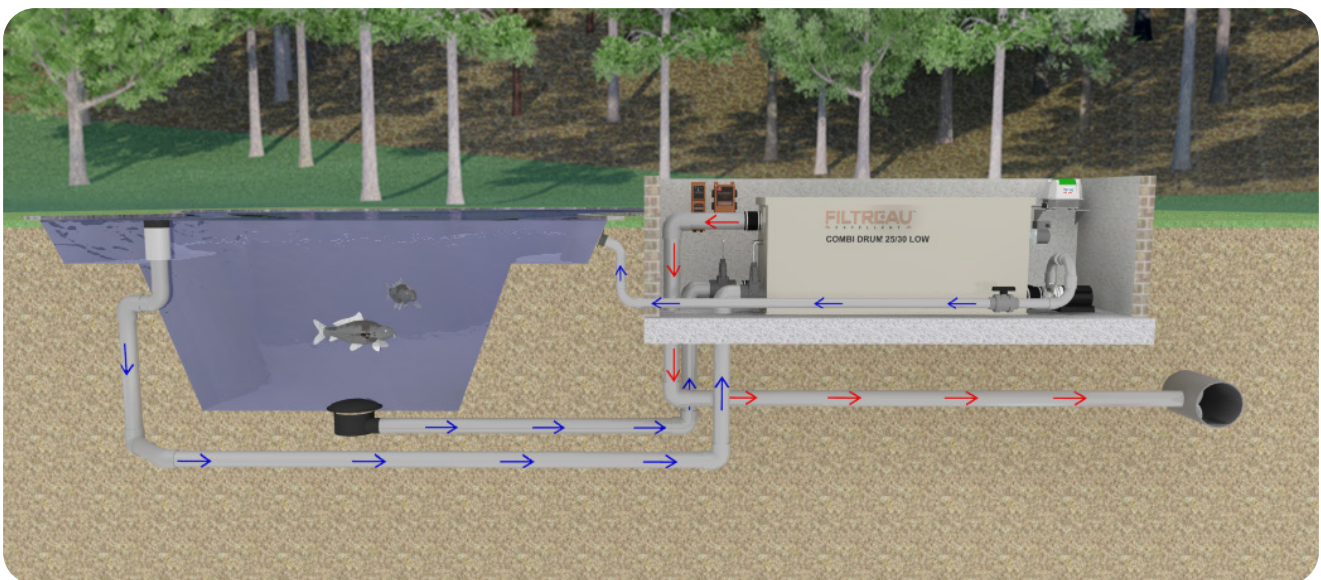



Dimensions

Excellent line

Dimensions WMC01DRG Bio Drum 25 M Gravity

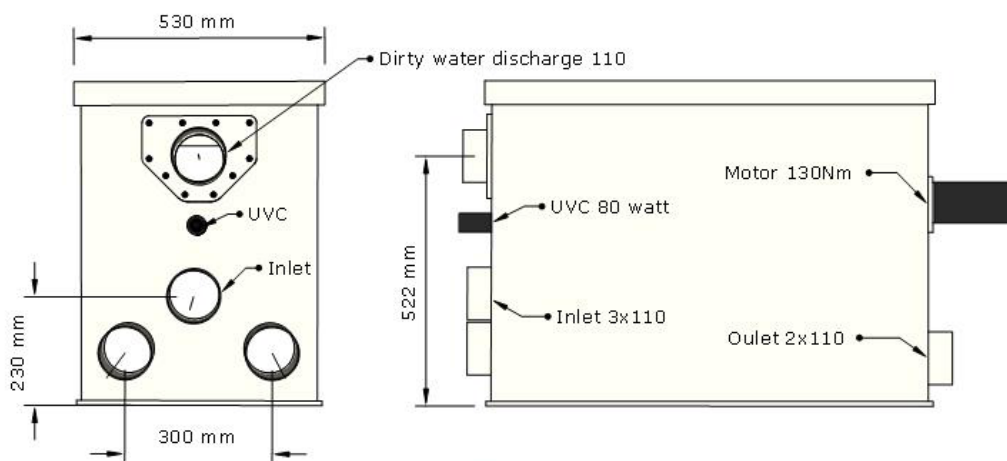
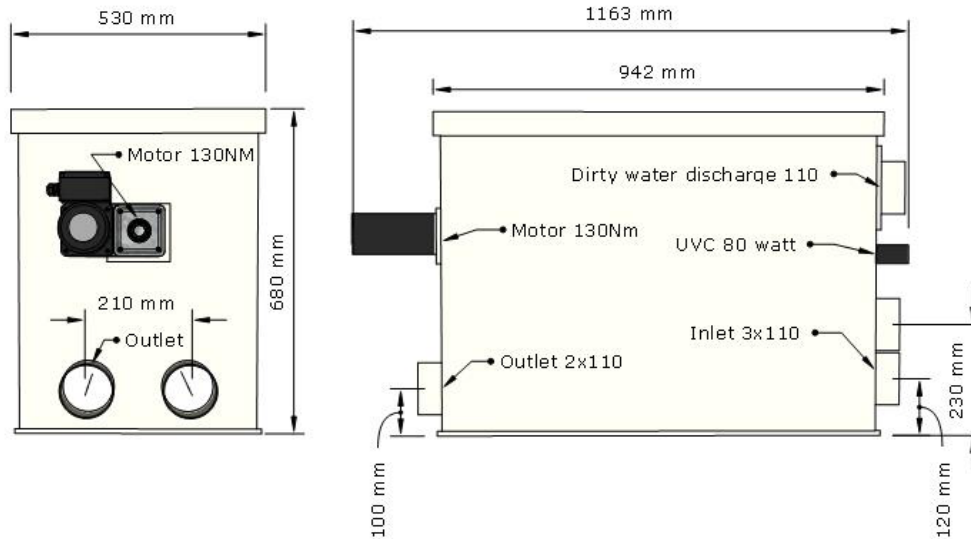

FILTREAU
EXCELLENT

WMC01DRG	Bio drum 25 M
----------	---------------



Download online

EXCELLENT LINE

Dimensions WMC01DRP Bio Drum 25 M Pump

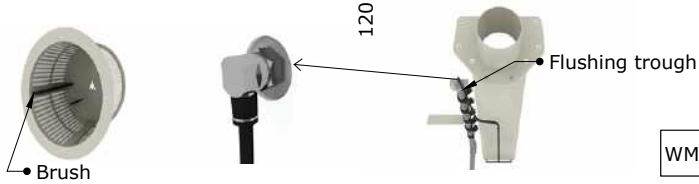
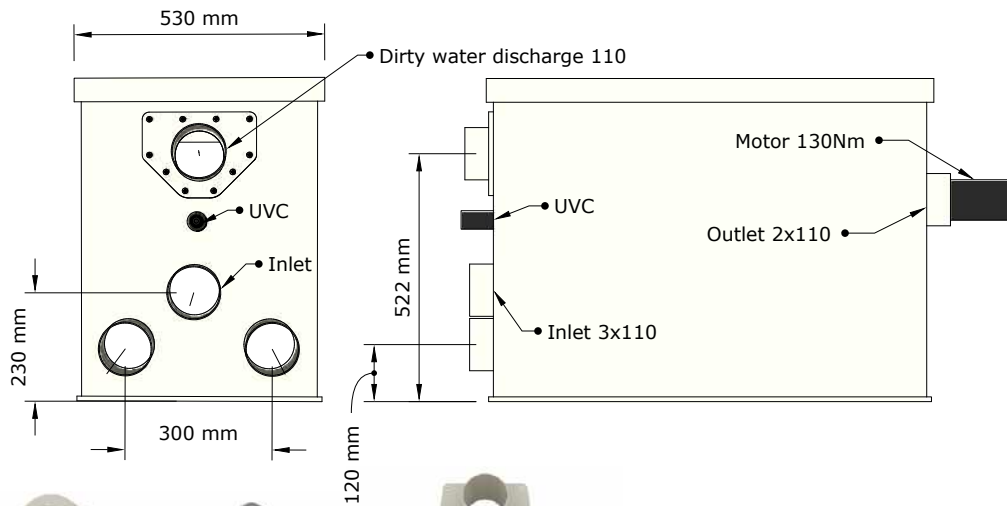
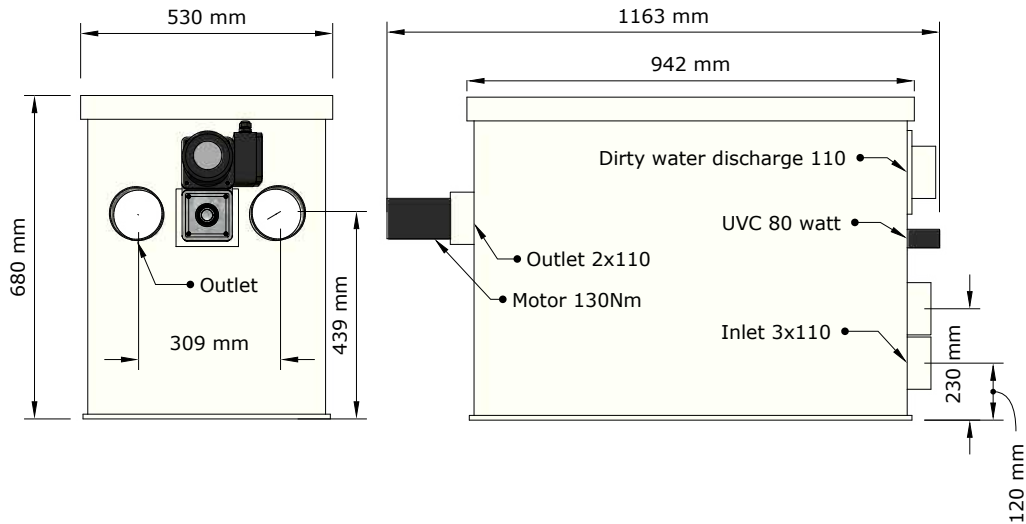

FILTREAU™
EXCELLENT

WMC01DRP	Bio drum 25 M
----------	---------------



[Download online](#)

Dimensions WMC02DRG Bio Drum 35 L Gravity

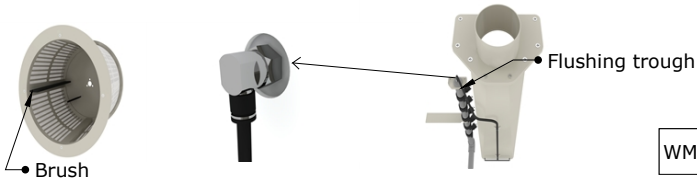
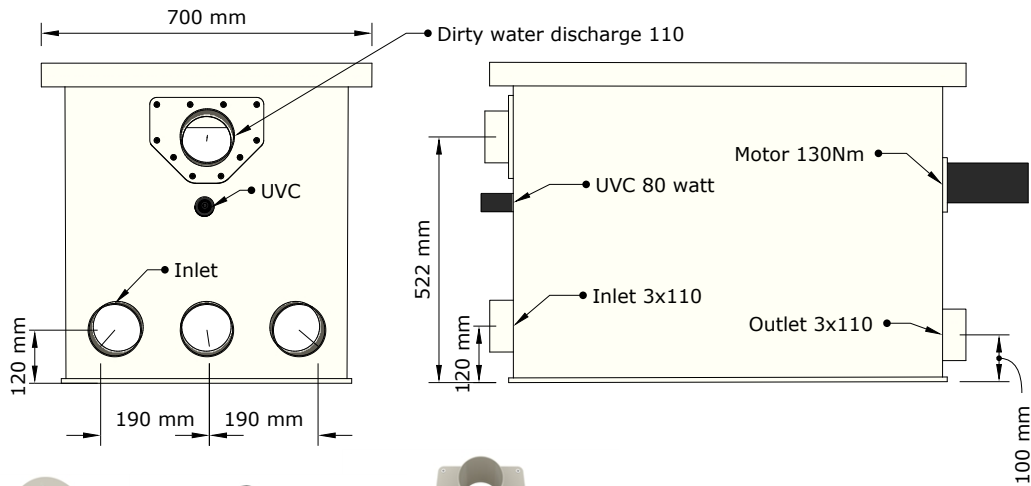
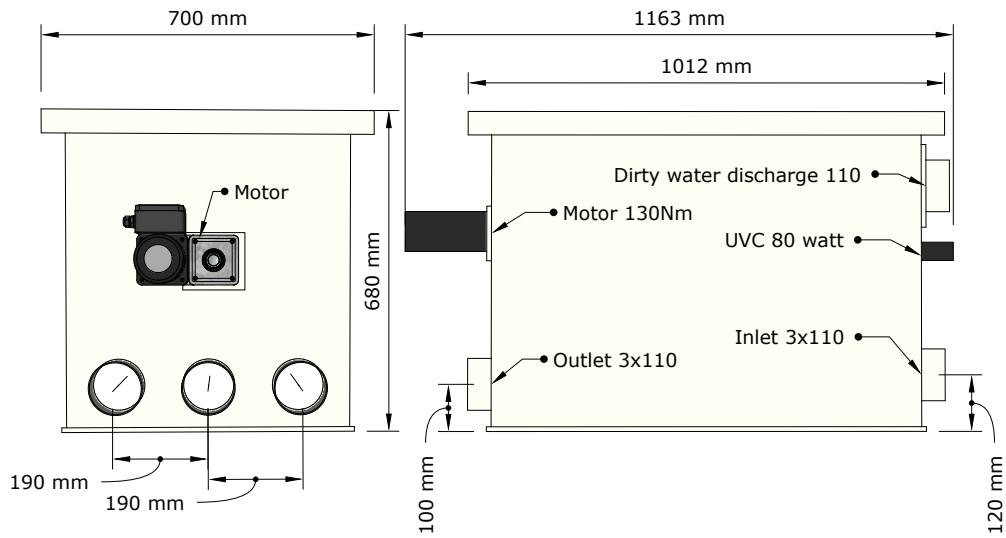

FILTREAU™
EXCELLENT

WMC02DRG	Bio drum 35 L
----------	---------------



Download online

EXCELLENT LINE

Dimensions WMC02DRP Bio Drum 35 L Pump

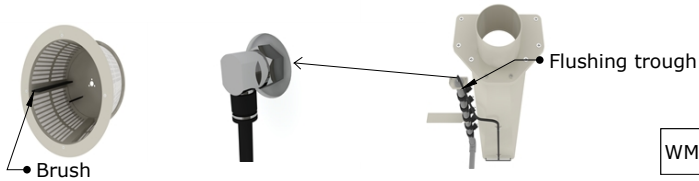
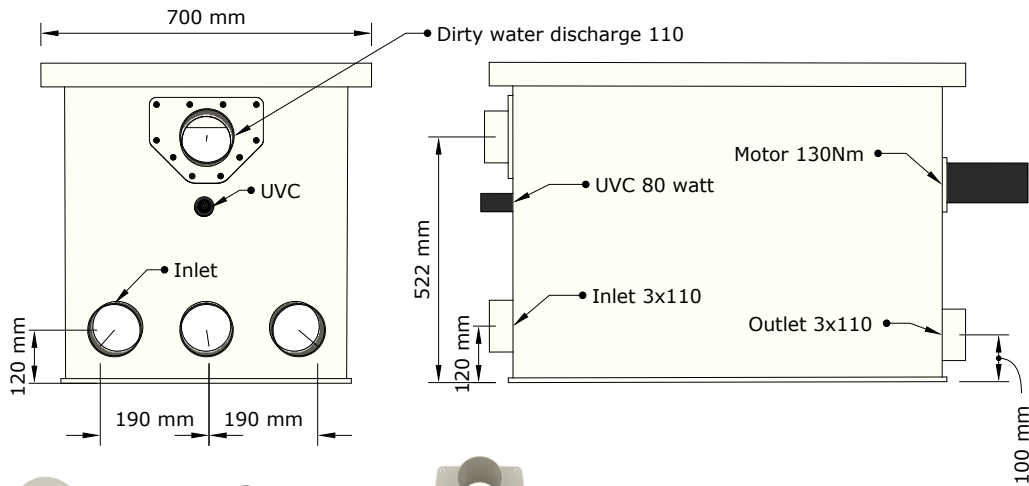
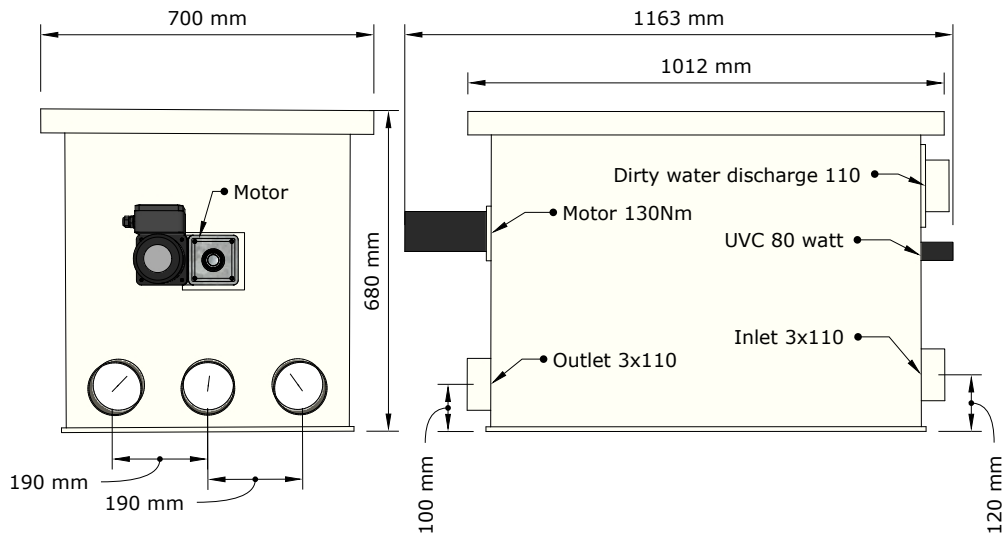

FILTREAU™
EXCELLENT

WMC02DRG	Bio drum 35 L
----------	---------------



[Download online](#)

Dimensions WMC03DRG Bio Drum 60 XL Gravity

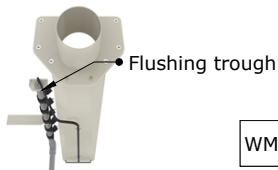
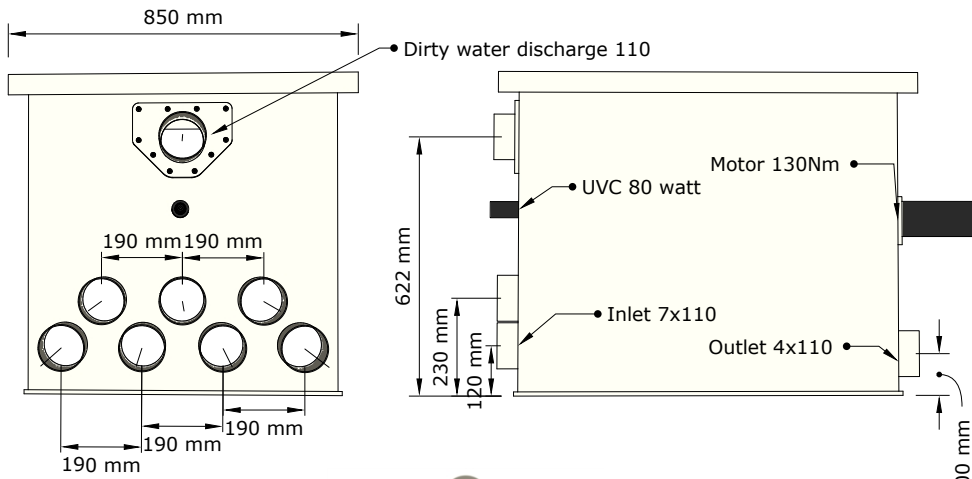
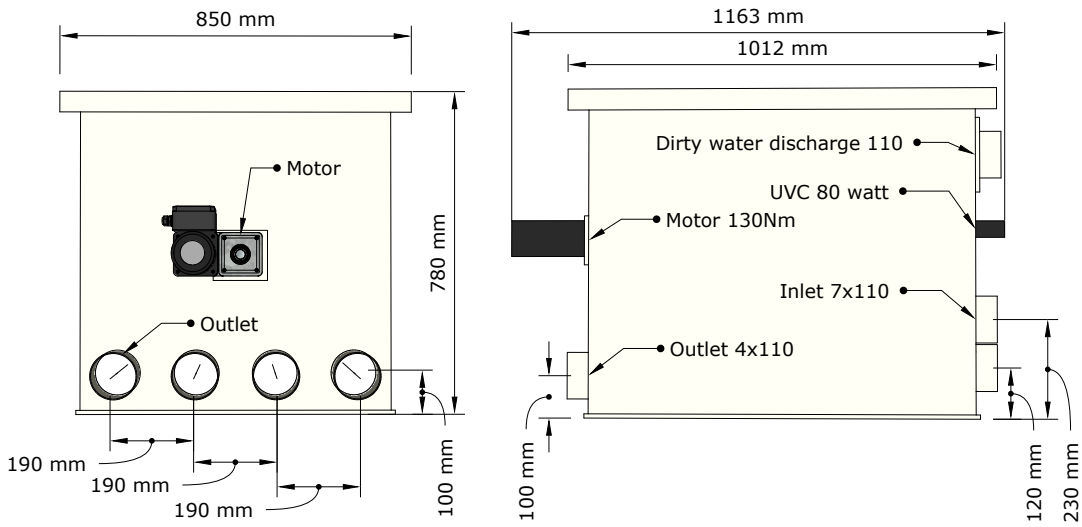

FILTREAU
EXCELLENT

WMC03DRG	Bio drum 60 XL
----------	----------------



Download online

EXCELLENT LINE

Dimensions WMC03DRP Bio Drum 60 XL Pump

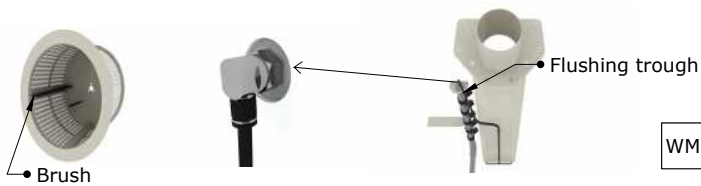
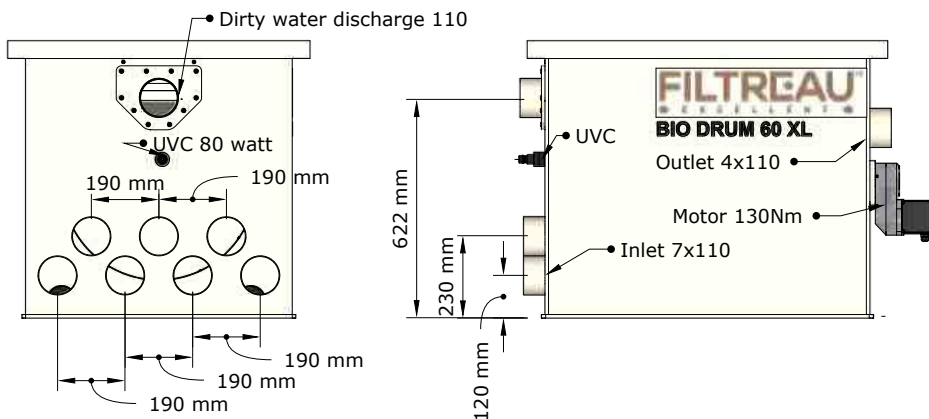
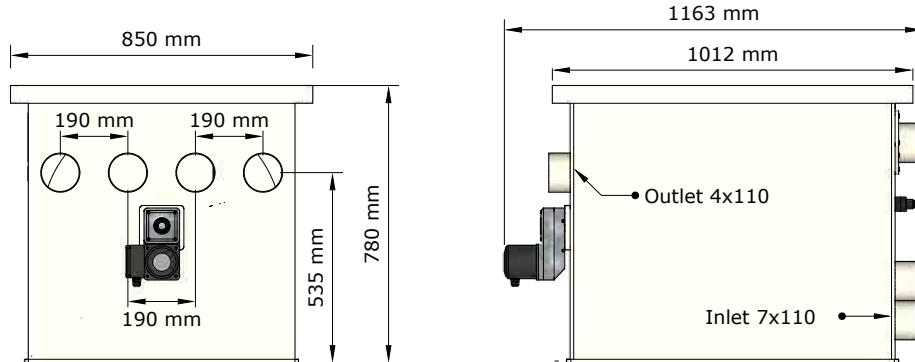

FILTREAU™
EXCELLENT

WMC03DRP	Bio drum 60 XL
----------	----------------



[Download online](#)

Dimensions WMC04DGP Bio Drum 100 XXL Gravity

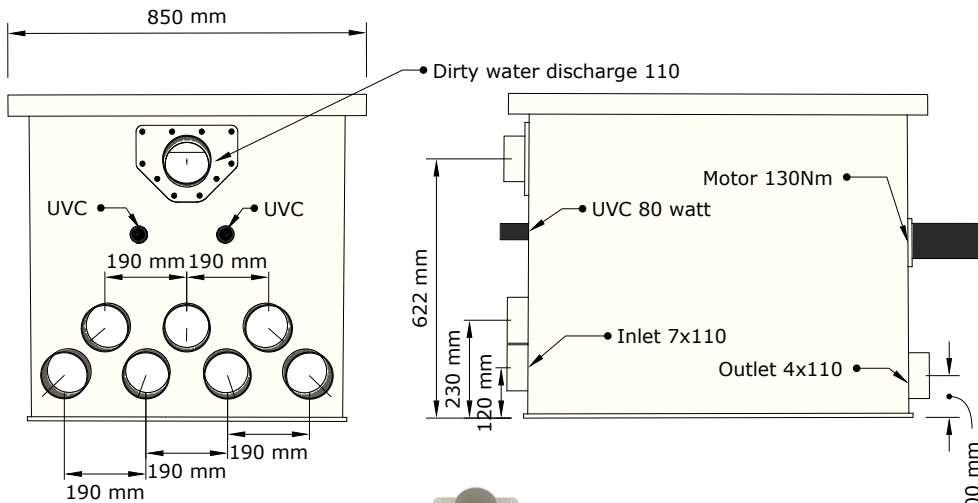
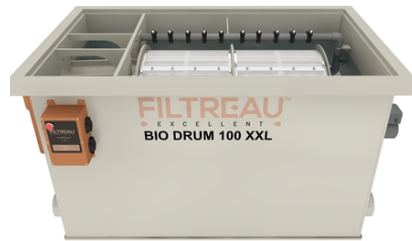
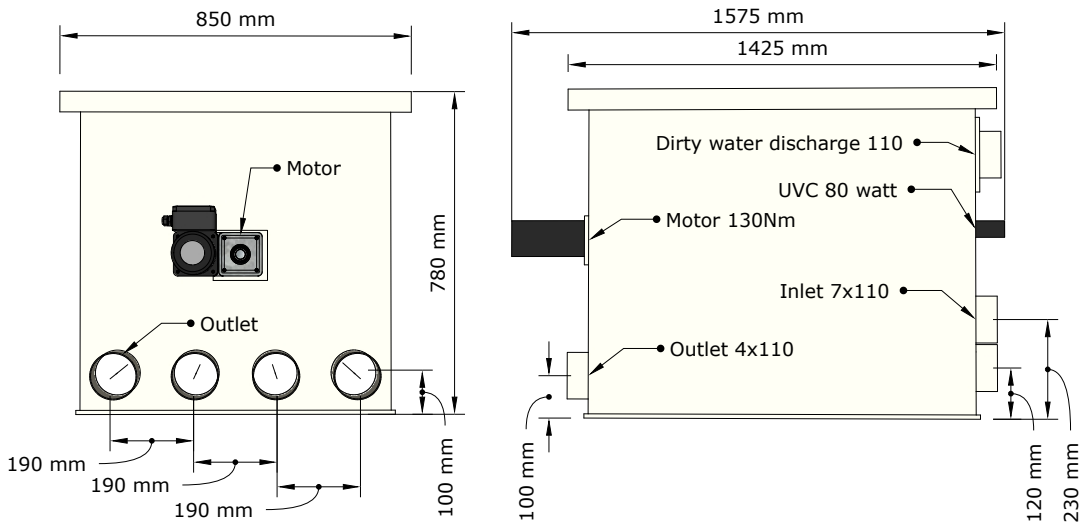

WMC04DRG	Bio drum 100 XXL
----------	------------------



Download online

EXCELLENT LINE

Dimensions WMC04DRP Bio Drum 100 XXL Pump

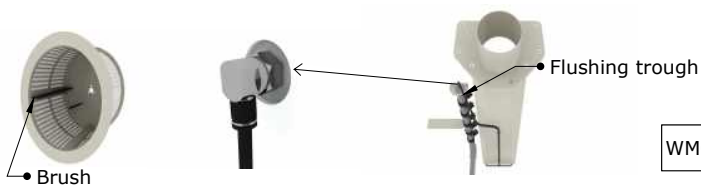
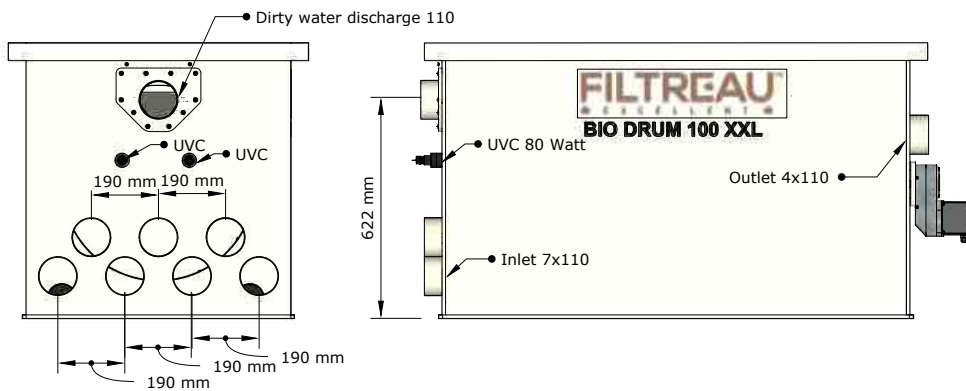
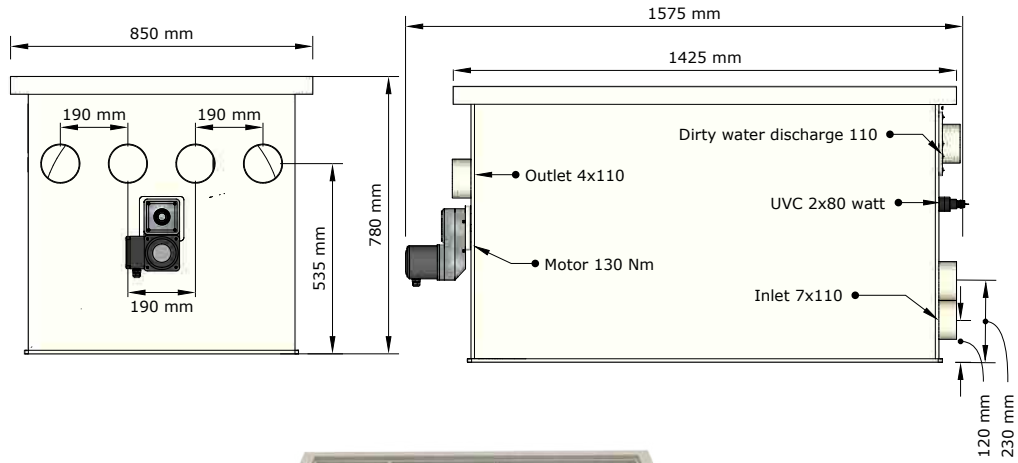

FILTREAU™
EXCELLENT

WMC04DRP Bio drum 100 XXL



[Download online](#)

Dimensions WMC05DRG Bio Drum 10 XS Gravity

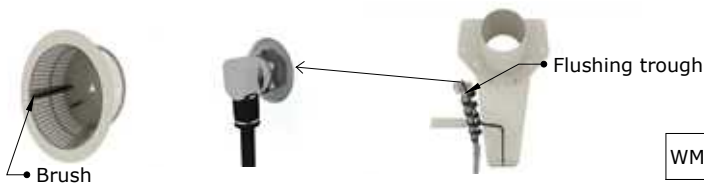
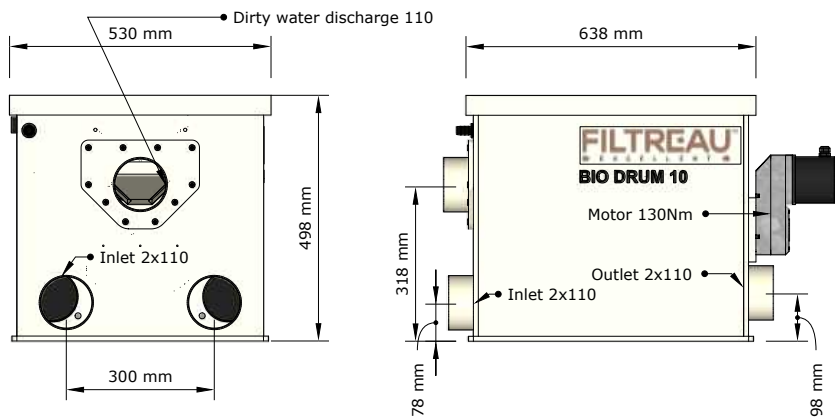
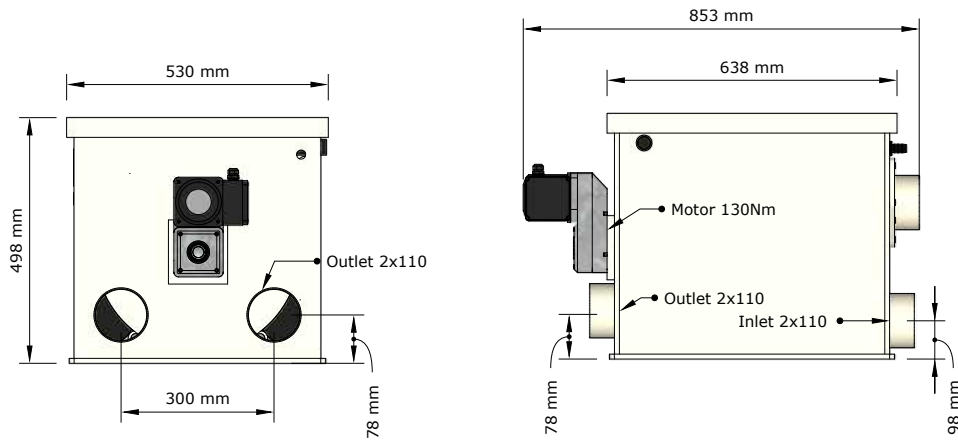

FILTREAU
EXCELLENT

WMC05DRG	Bio drum 10
----------	-------------



Download online

EXCELLENT LINE

Dimensions WMC05DRP Bio Drum 10 XS Pump

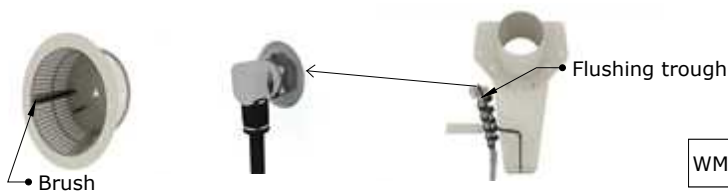
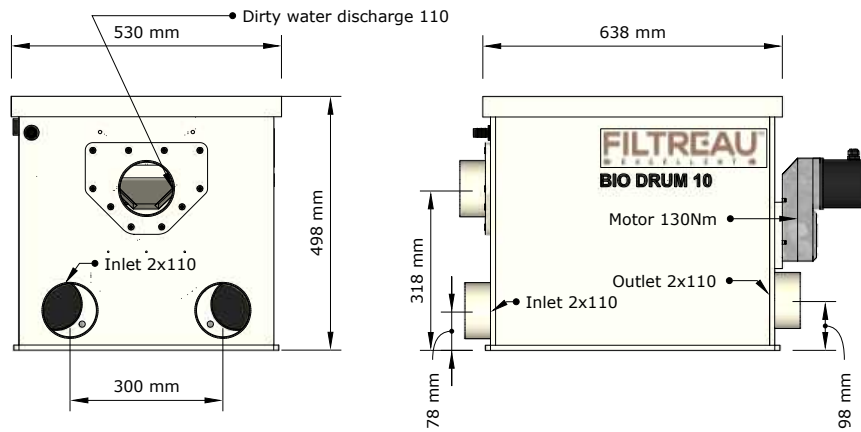
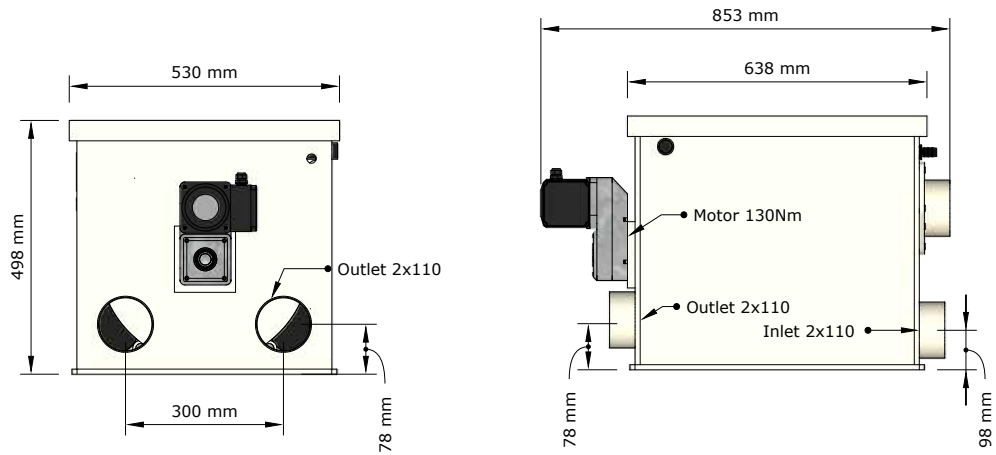

Dimensions WMC06DRG Bio Drum 15 S Gravity

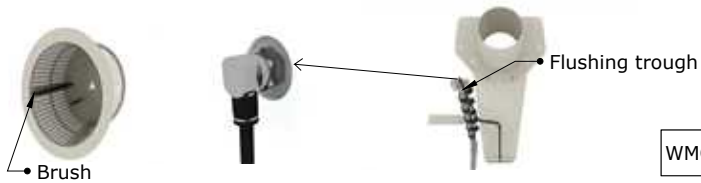
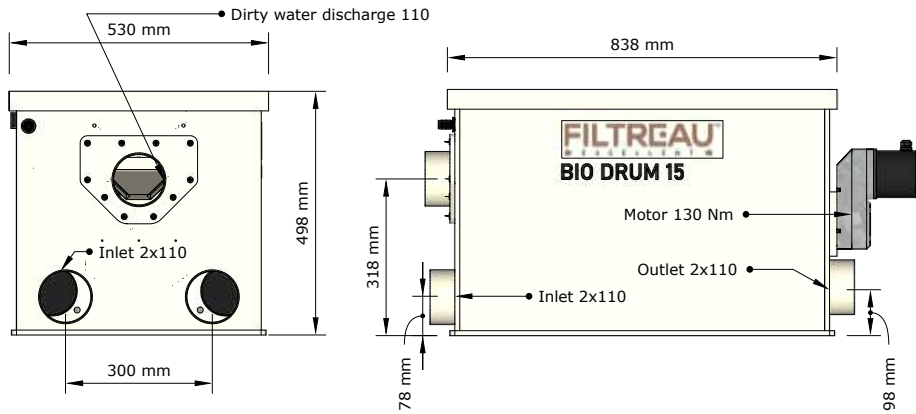
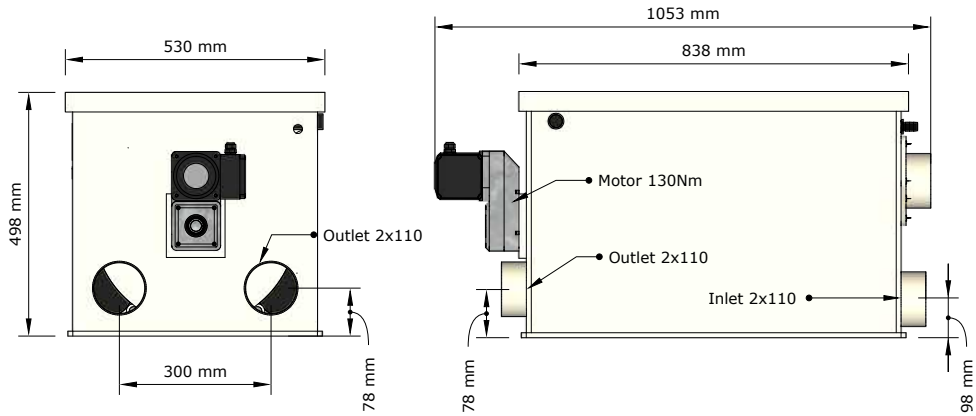

FILTREAU
EXCELLENT

WMC06DRGS	Bio drum 15
-----------	-------------



Download online

EXCELLENT LINE

Dimensions WMC06DRP Bio Drum 15 S Pump

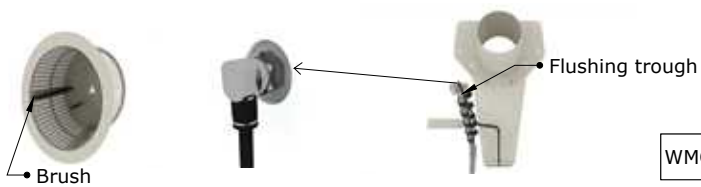
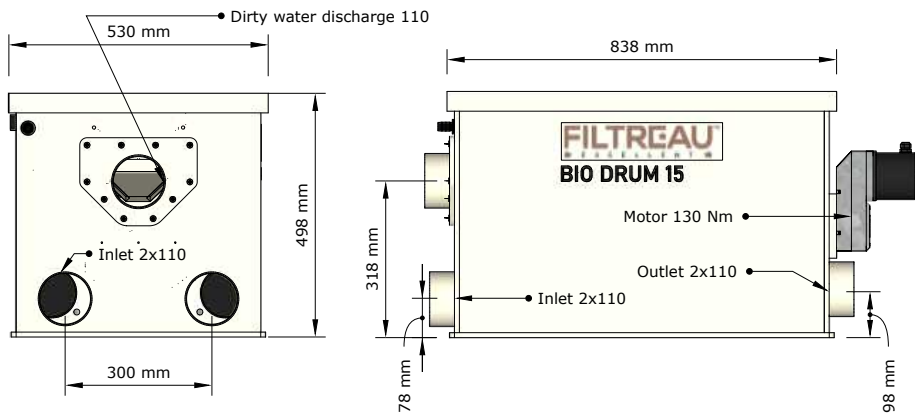
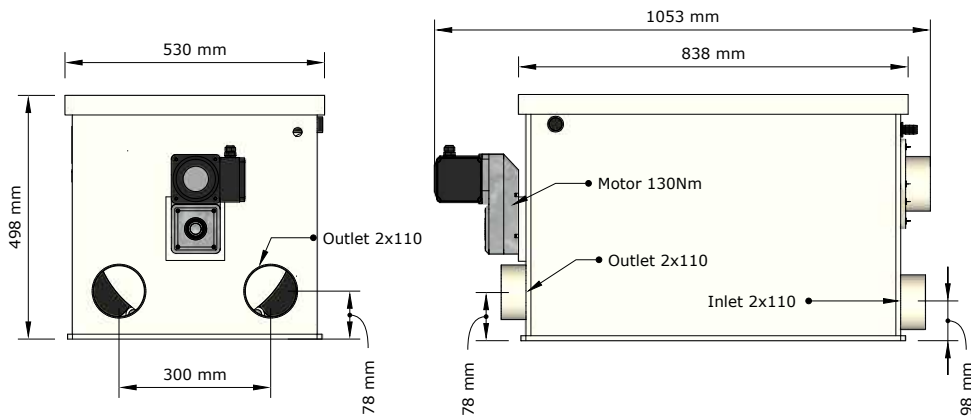

FILTREAU™
EXCELLENT

WMC06DRGS	Bio drum 15
-----------	-------------



[Download online](#)

Dimensions WMC07DRG Bio Drum 40 Ultra Gravity

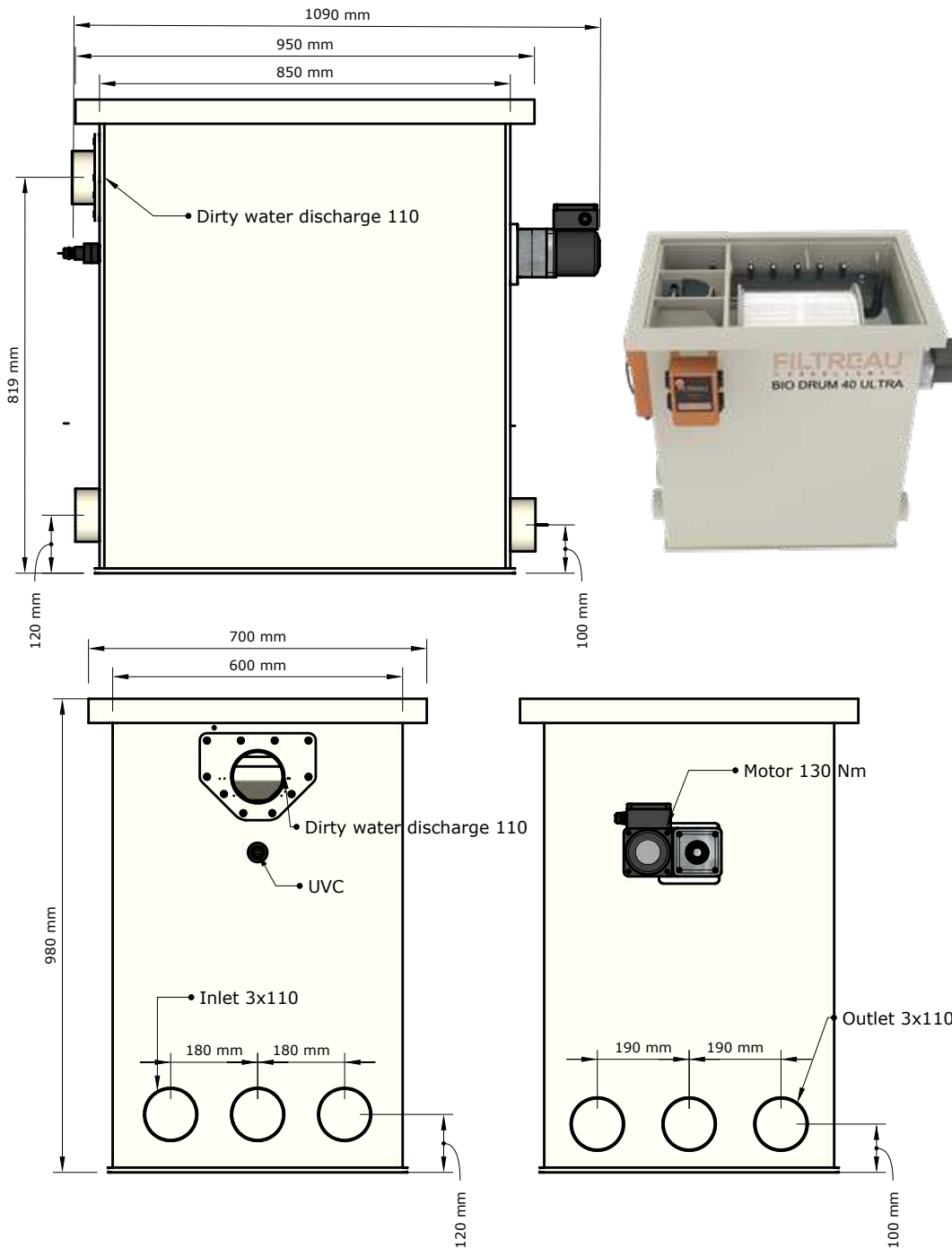

WMC07DRG Bio drum 40 ultra



Download online

EXCELLENT LINE

Dimensions WMC07DRP Bio Drum 40 Ultra Pump

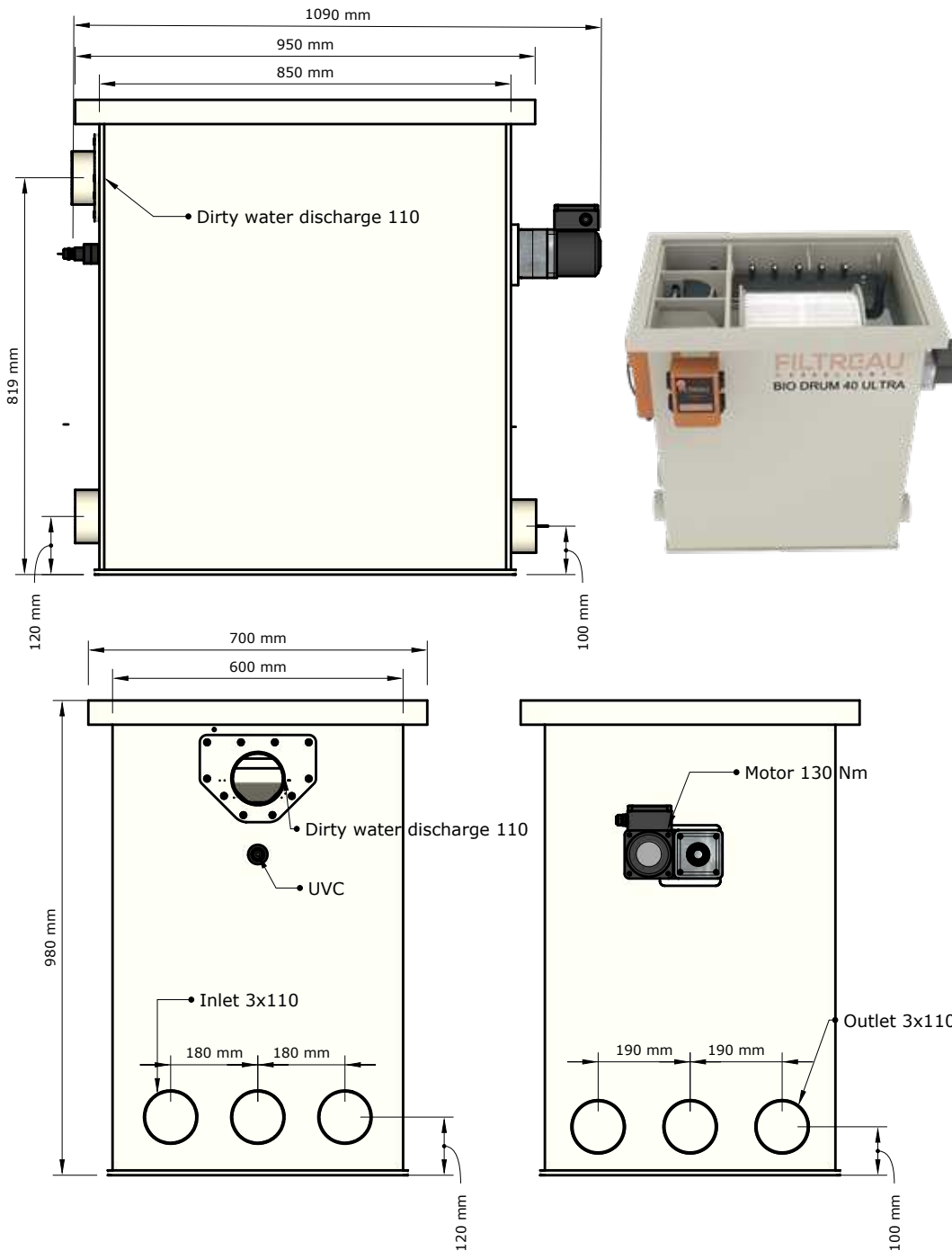

FILTREAU™
EXCELLENT

WMC07DRG Bio drum 40 ultra



[Download online](#)

Dimensions WMC08PPG Combi Drum 10/15 Low Gravity

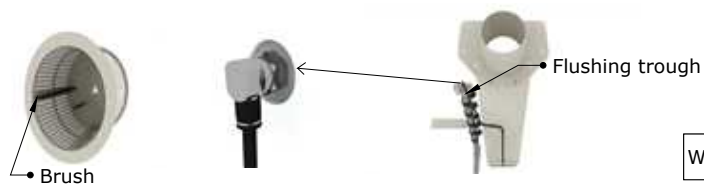
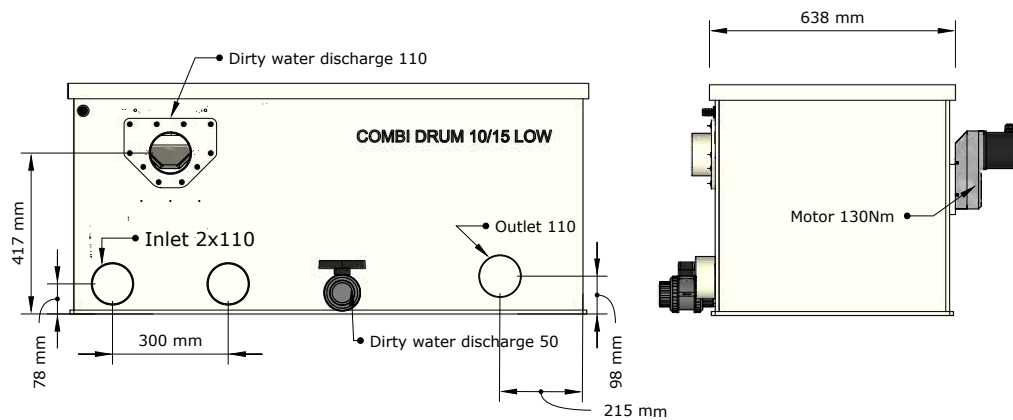
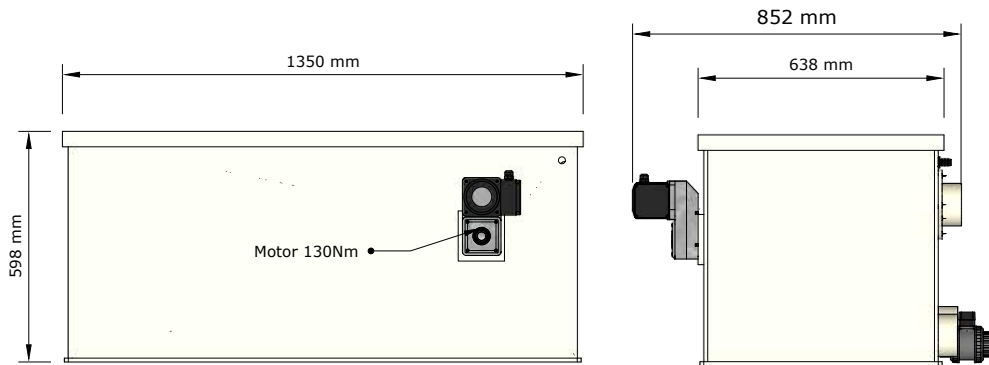

FILTREAU
EXCELLENT

WMC08PPG	COMBI DRUM 10/15 LOW
----------	-------------------------



Download online

EXCELLENT LINE

Dimensions WMC08PPG Combi Drum 10/15 Low

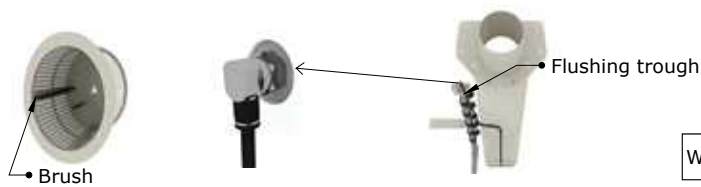
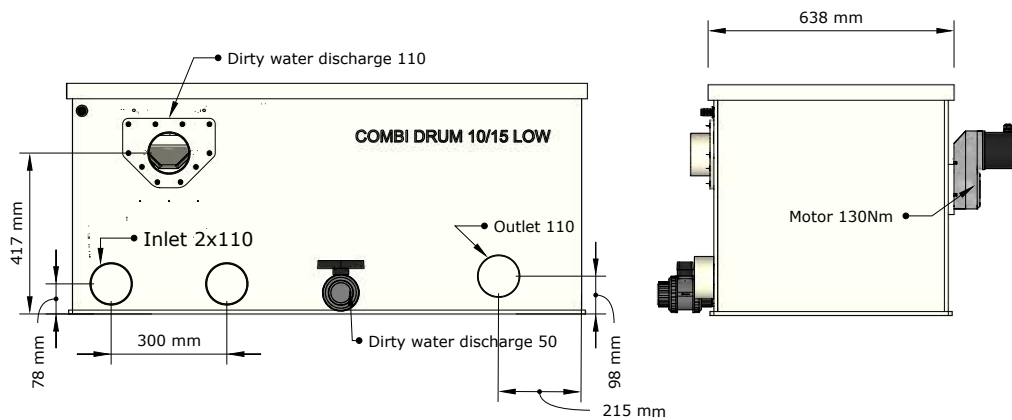
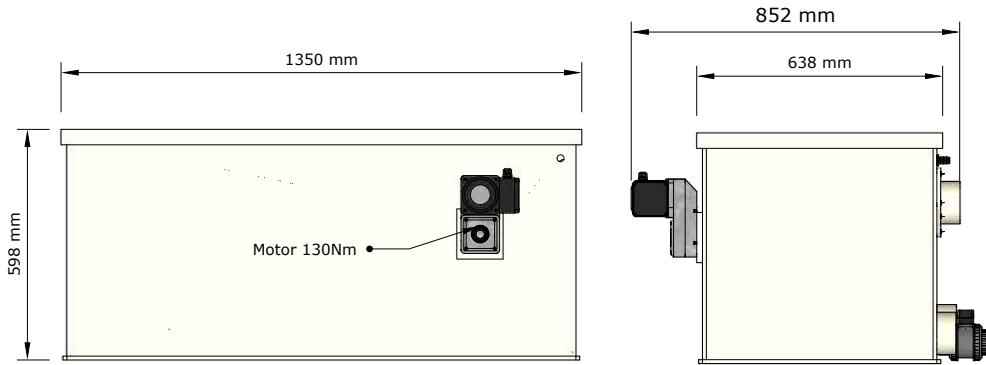

FILTREAU™
EXCELLENT

WMC08PPG	COMBI DRUM 10/15 LOW
----------	-------------------------



[Download online](#)

Dimensions WMC09PPG Combi Drum 20/25 Gravity

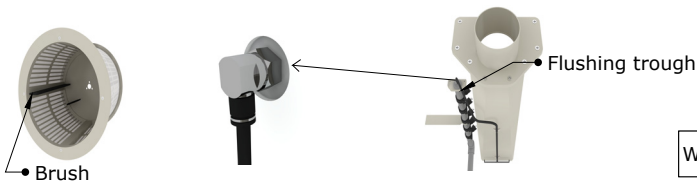
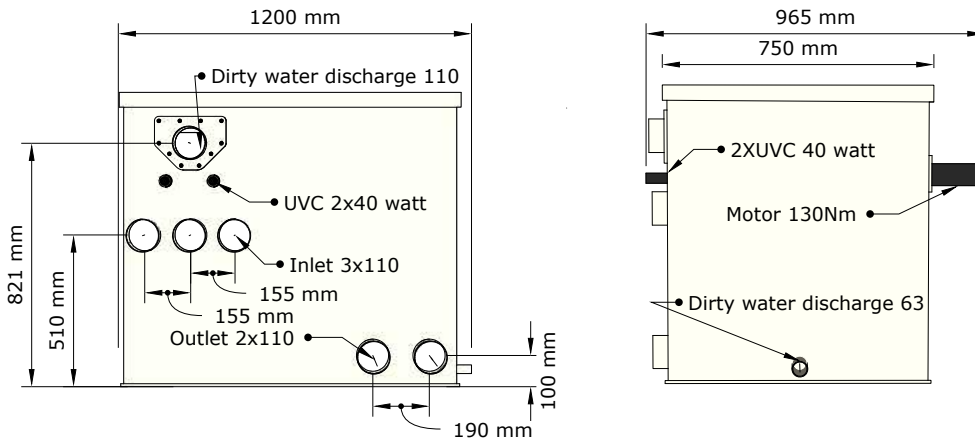
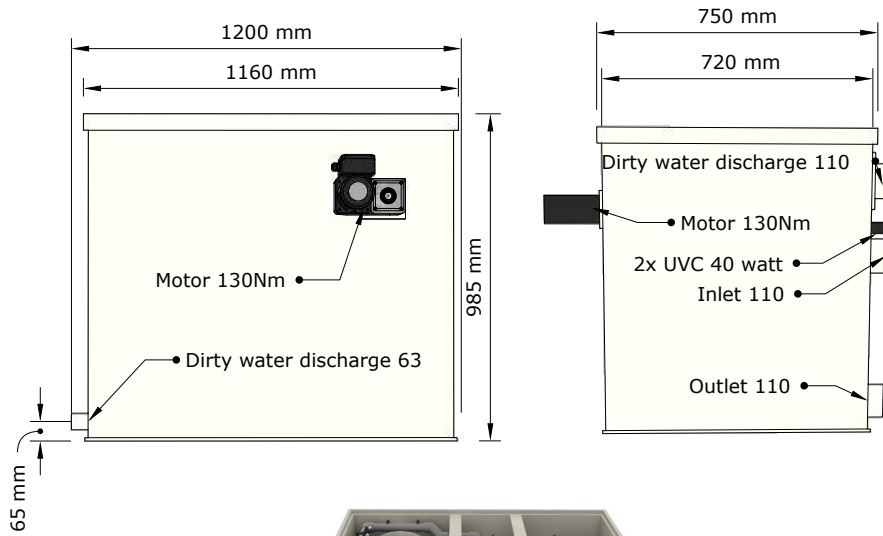

FILTREAU™
EXCELLENT

WMC09PPG	COMBI DRUM 20/25
----------	------------------



Download online

EXCELLENT LINE

Dimensions WMC09PPP Combi Drum 20/25 Pump

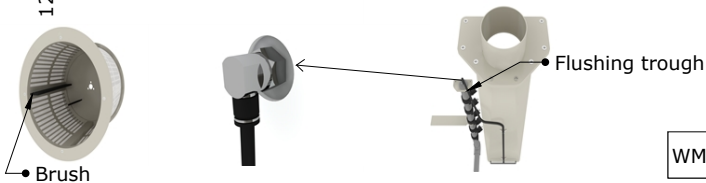
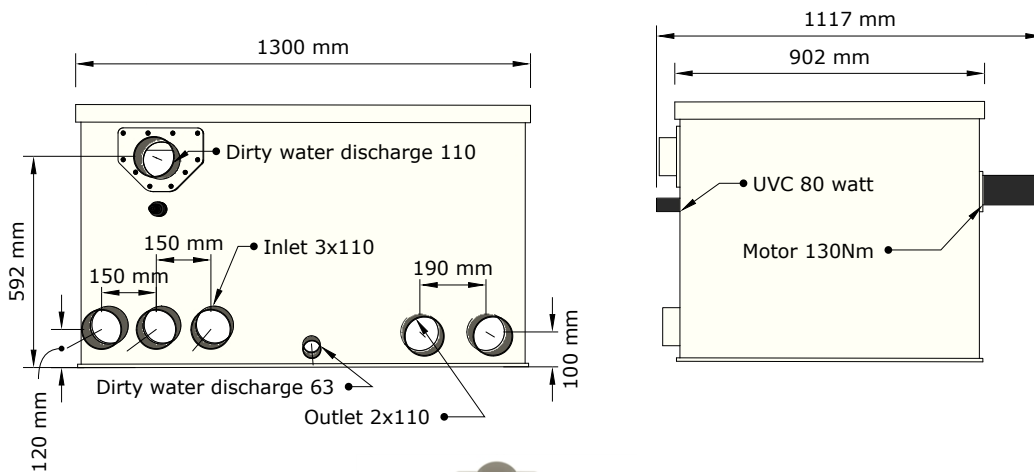
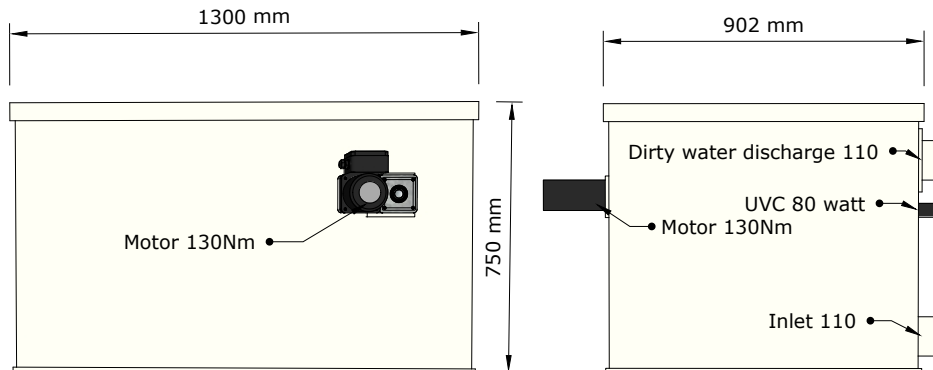

FILTREAU™
EXCELLENT

WMC20CDG	COMBI DRUM 25/30 LOW
----------	-------------------------



Download online

Dimensions WMC10PPG Combi Drum 25/30 Gravity

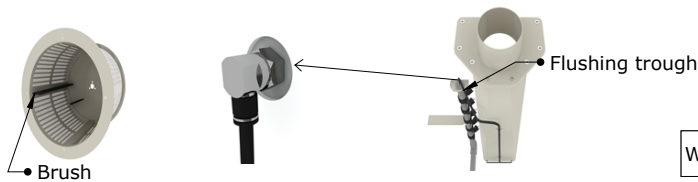
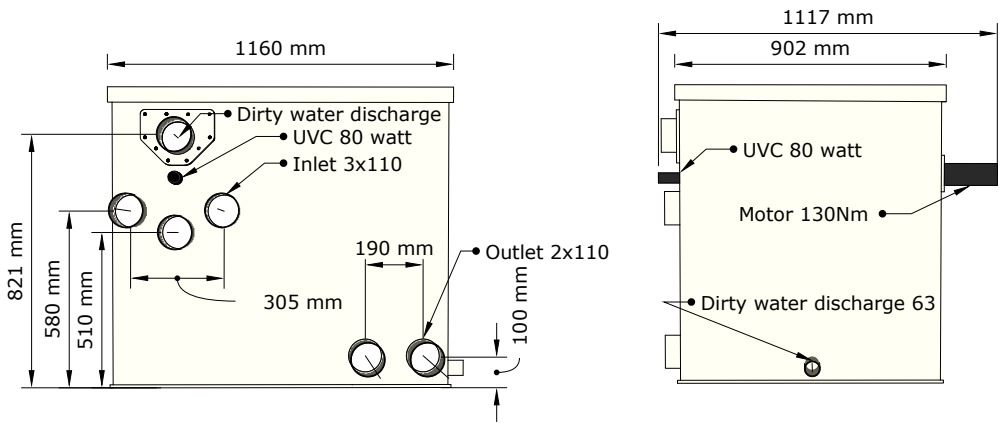
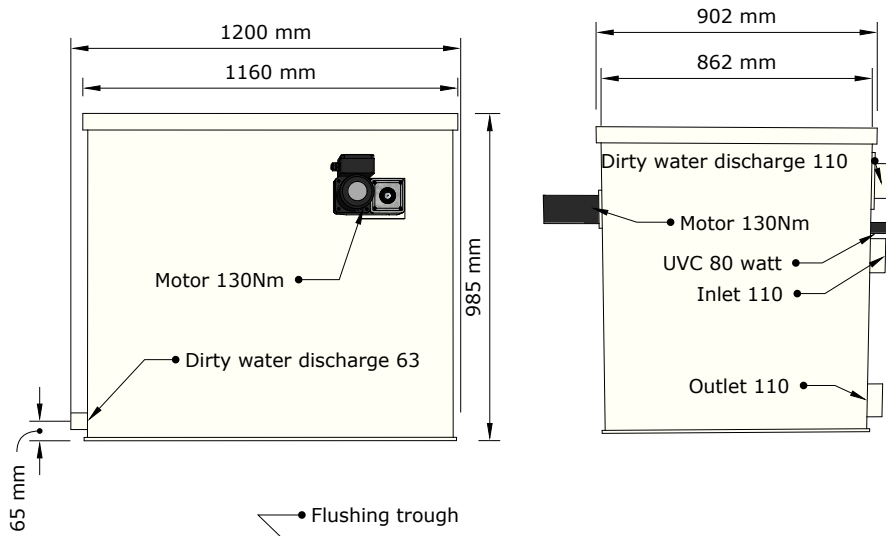

FILTREAU™
EXCELLENT

WMC10PPG	COMBI DRUM 25/30
----------	------------------



Download online

EXCELLENT LINE

Dimensions WMC10PPP Combi Drum 25/30 Pump

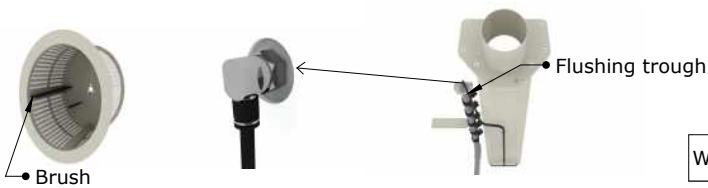
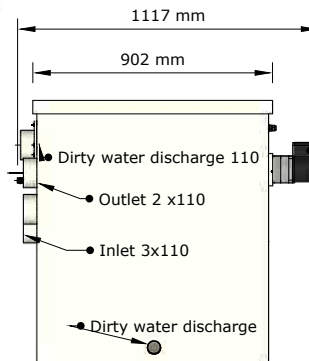
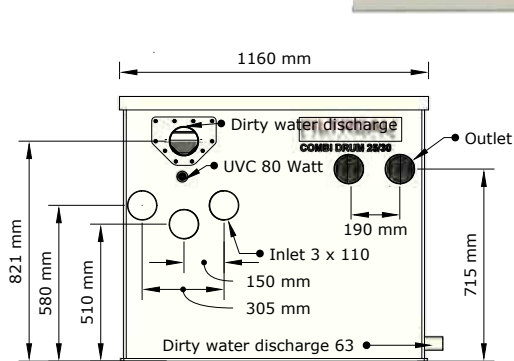
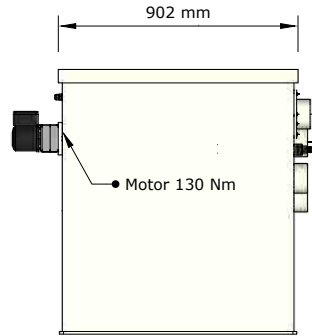
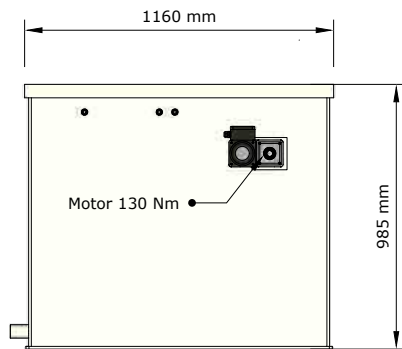

FILTREAU™
EXCELLENT

WMC10PPP

COMBI DRUM 25/30



[Download online](#)

Dimensions WMC10PPT Combi Drum 25/30 Trickle

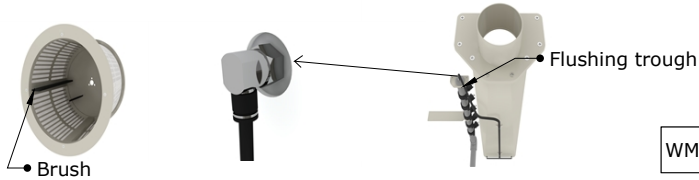
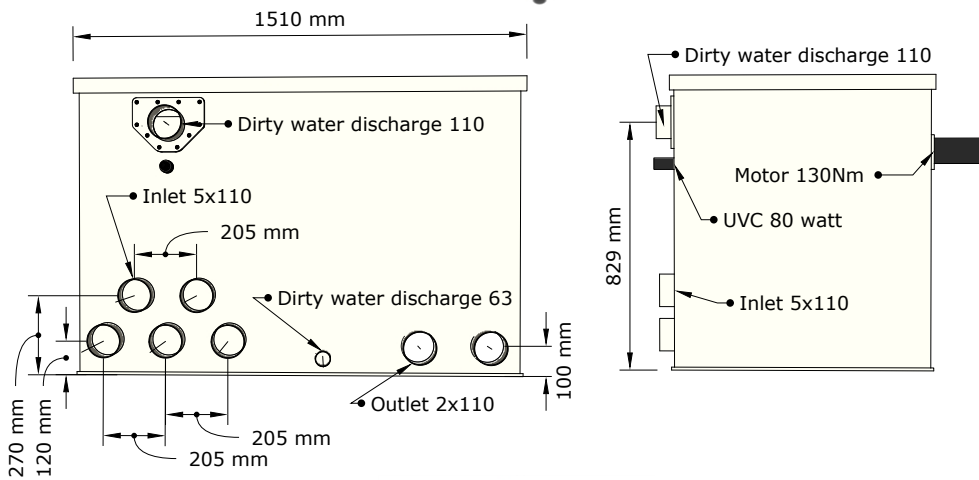
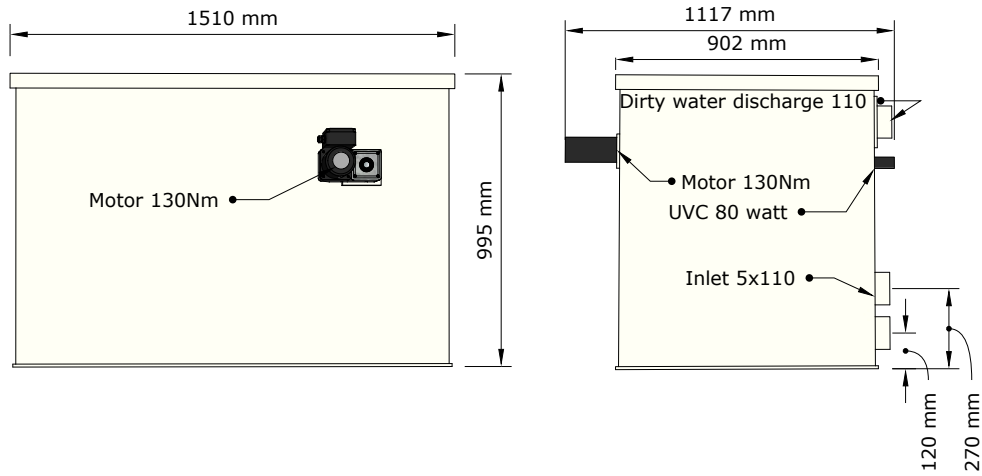

FILTREAU™
EXCELLENT

WMC21CDG	COMBI DRUM 30/50
----------	------------------



Download online

EXCELLENT LINE

Dimensions WMC11PPG Combi Drum 20/25 Low Gravity

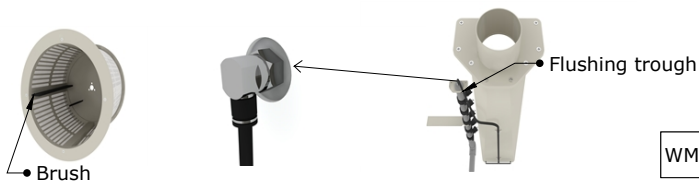
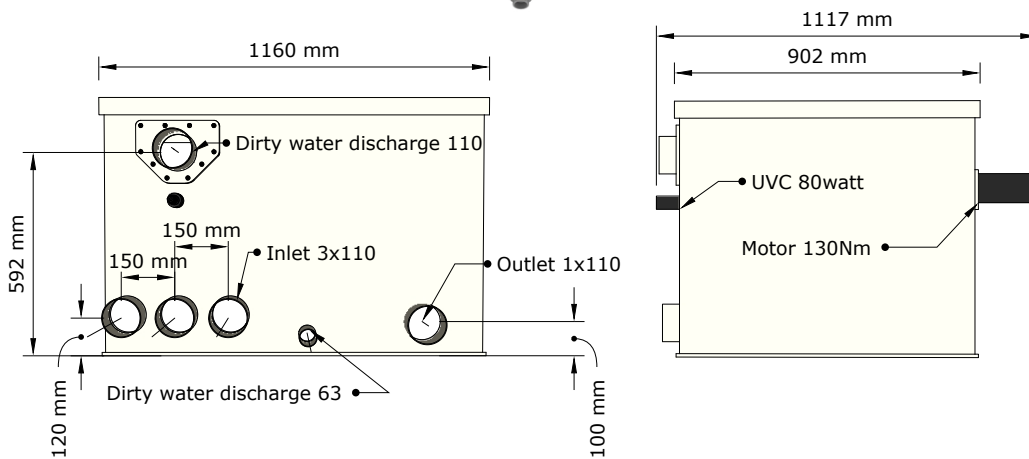
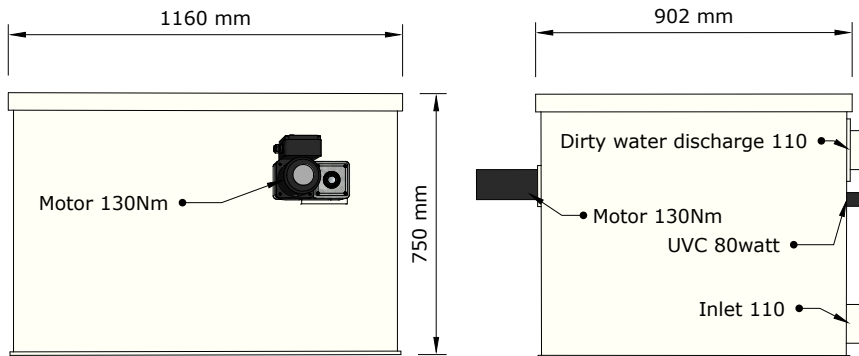

FILTREAU™
EXCELLENT

WMC11PPG	COMBI DRUM 20/25 LOW
----------	-------------------------



[Download online](#)

Dimensions WMC11PPP Combi Drum 20/25 Low Pump

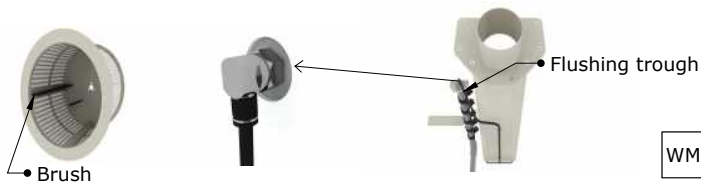
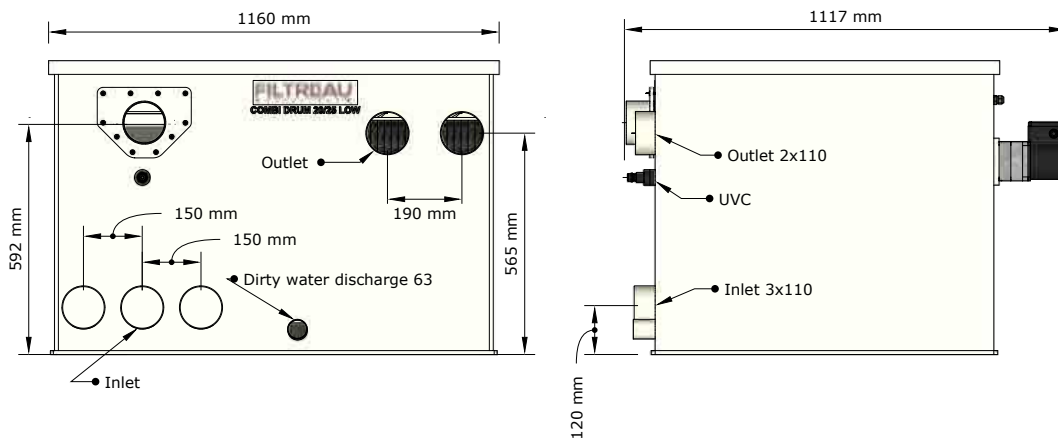
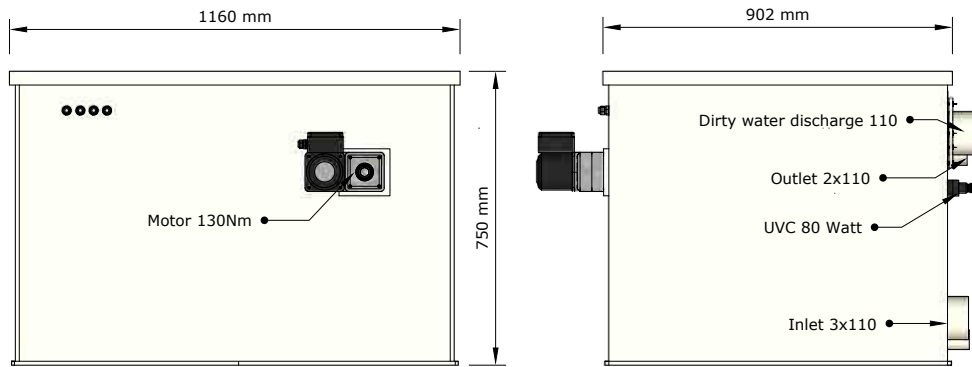

FILTREAU™
EXCELLENT

WMC11PPP	COMBI DRUM 20/25 LOW
----------	-------------------------



Download online

EXCELLENT LINE

Dimensions WMC11PPT Combi Drum 20/25 Low Trickle

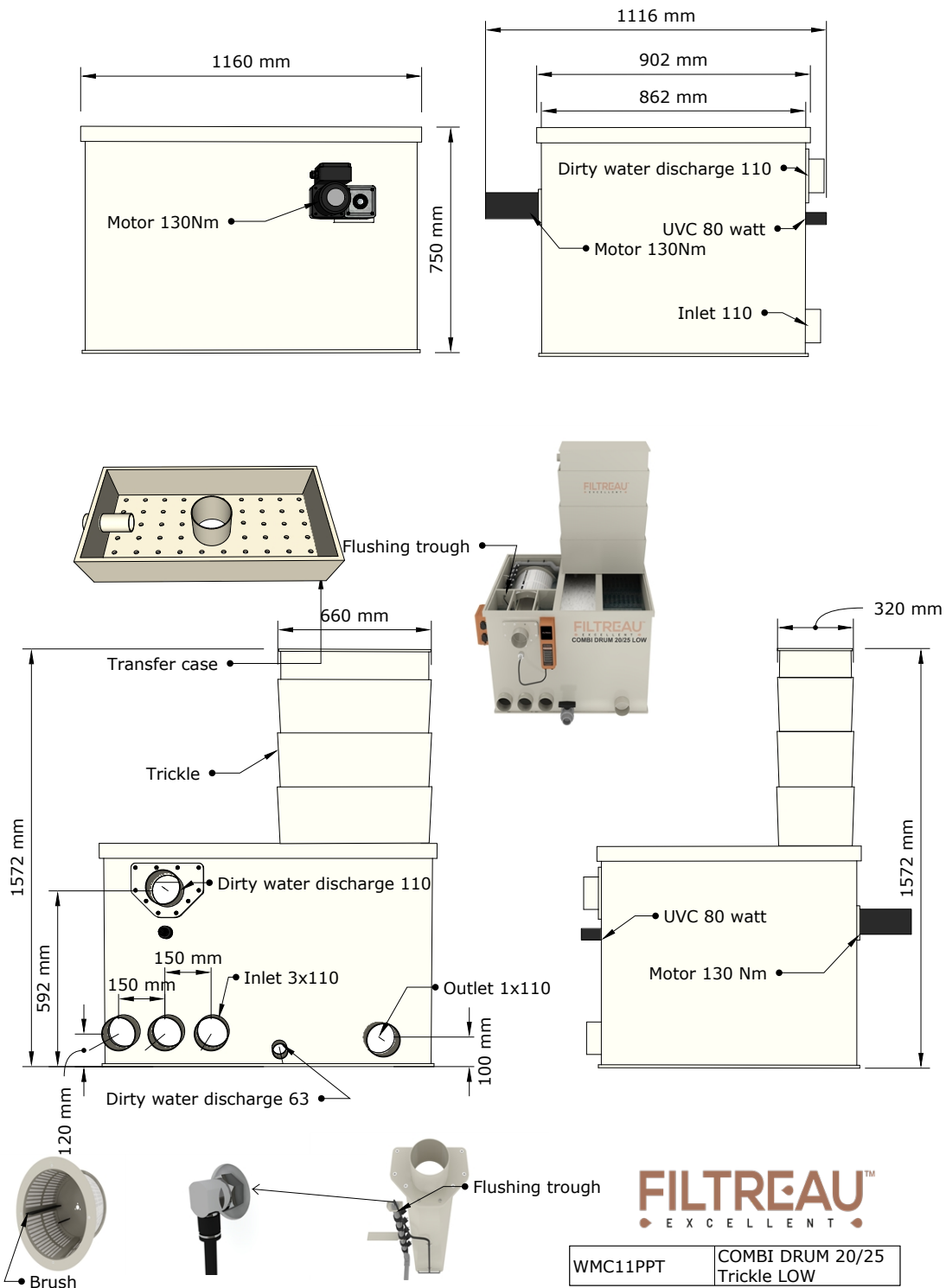

WMC11PPT	COMBI DRUM 20/25 Trickle LOW
----------	---------------------------------



[Download online](#)

Dimensions WMC20CDG Combi Drum 25/30 Low Gravity

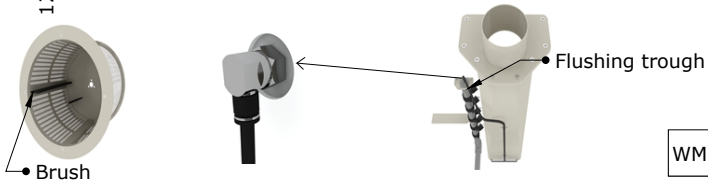
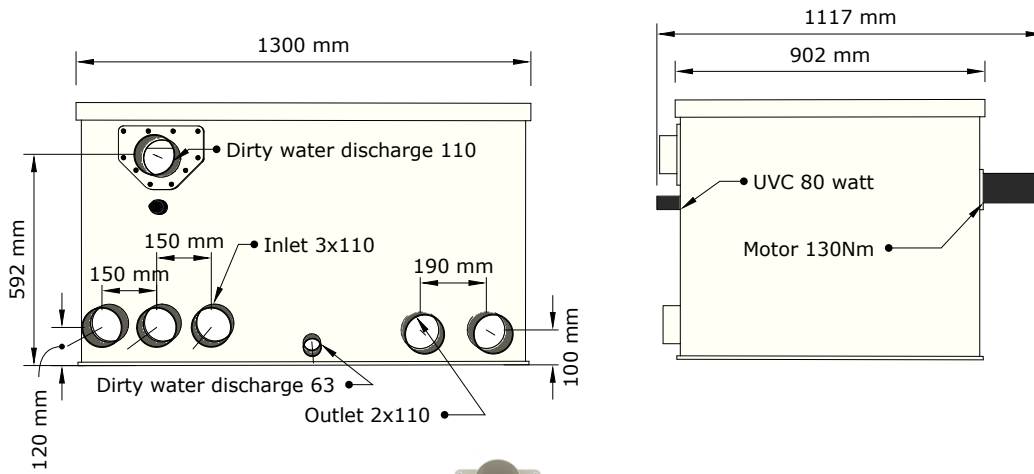
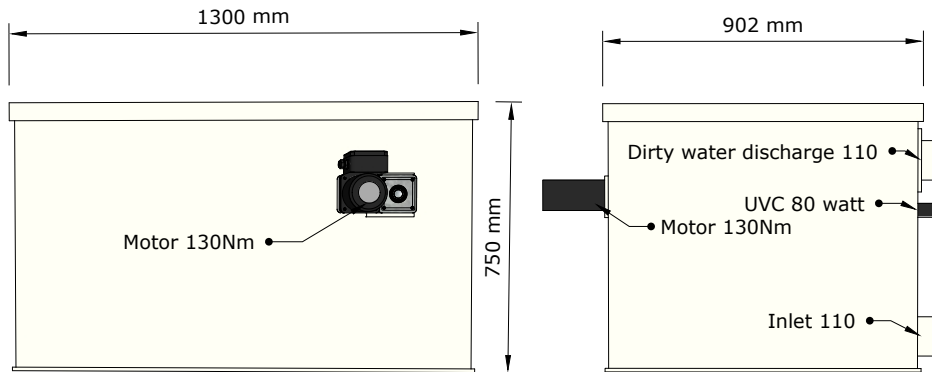

FILTREAU
EXCELLENT

WMC20CDG	COMBI DRUM 25/30 LOW
----------	-------------------------



Download online

EXCELLENT LINE

Dimensions WMC20CDP Combi Drum 25/30 Low Pump

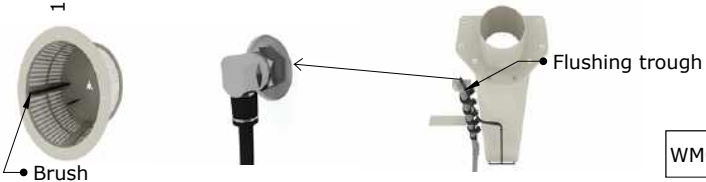
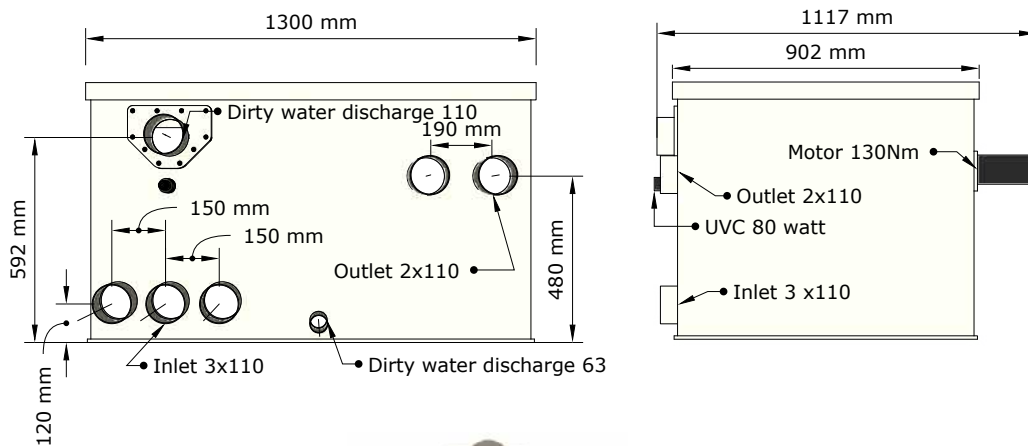
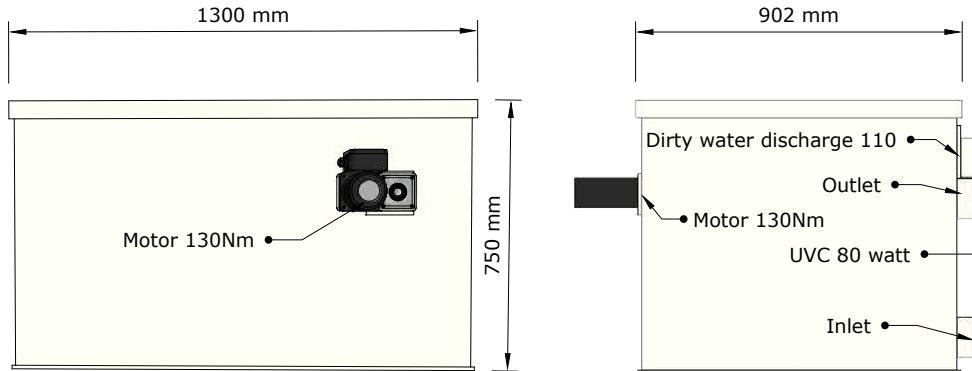

FILTREAU™
EXCELLENT

WMC20CDP	COMBI DRUM 25/30 LOW
----------	-------------------------



[Download online](#)

Dimensions WMC20CDT Combi Drum 25/30 Low Trickle

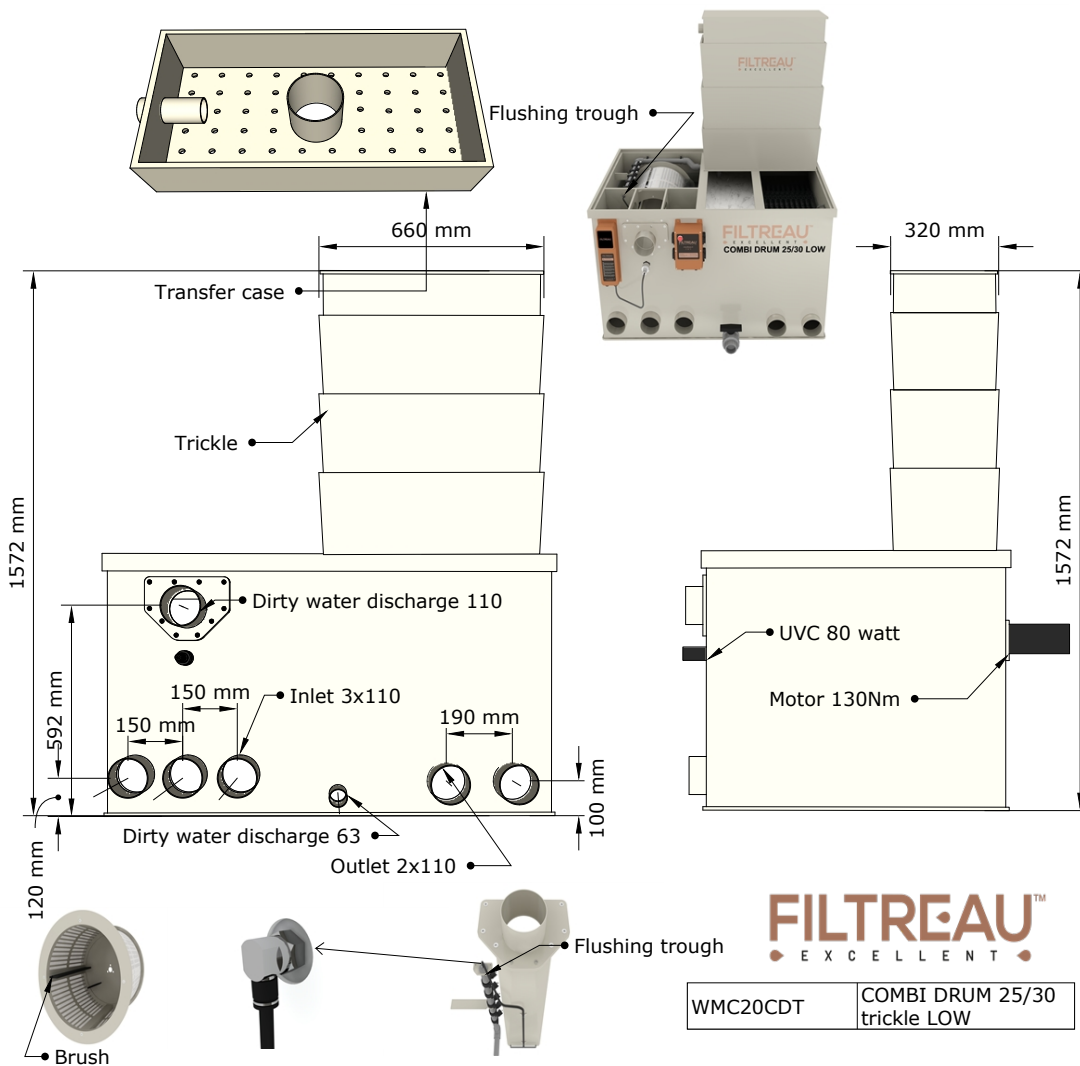
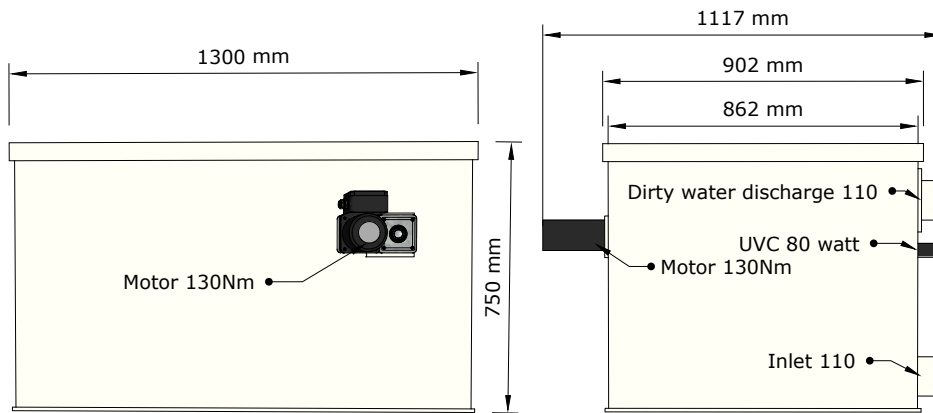

Download online

EXCELLENT LINE

Dimensions WMC21CDG Combi Drum 30/50 Gravity

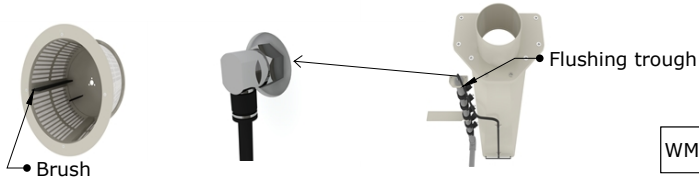
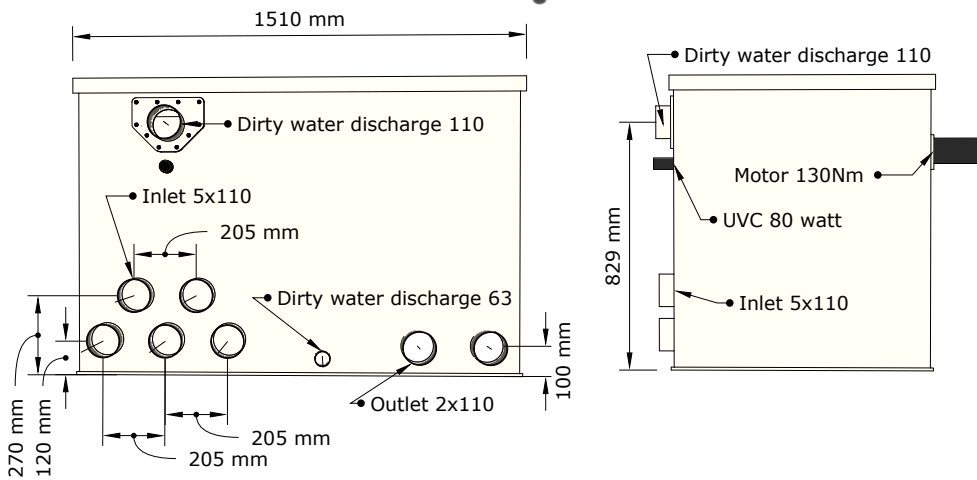
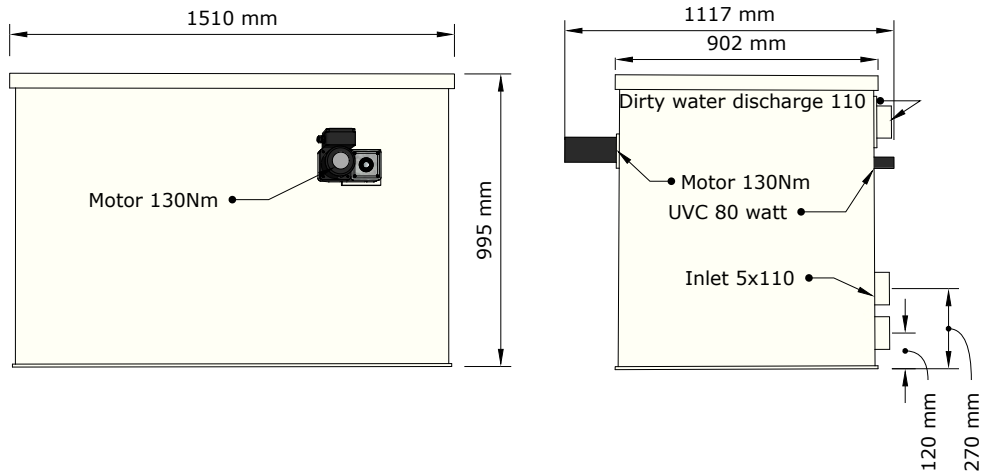

FILTREAU™
EXCELLENT

WMC21CDG	COMBI DRUM 30/50
----------	------------------



[Download online](#)

Dimensions WMC21CDP Combi Drum 30/50 Pump

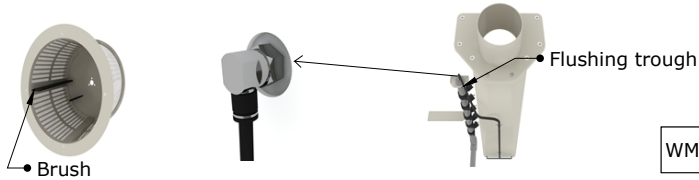
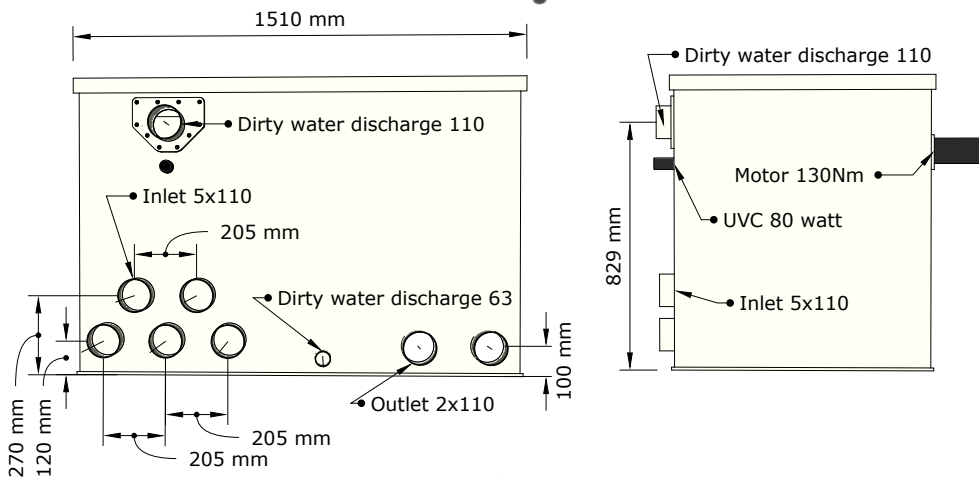
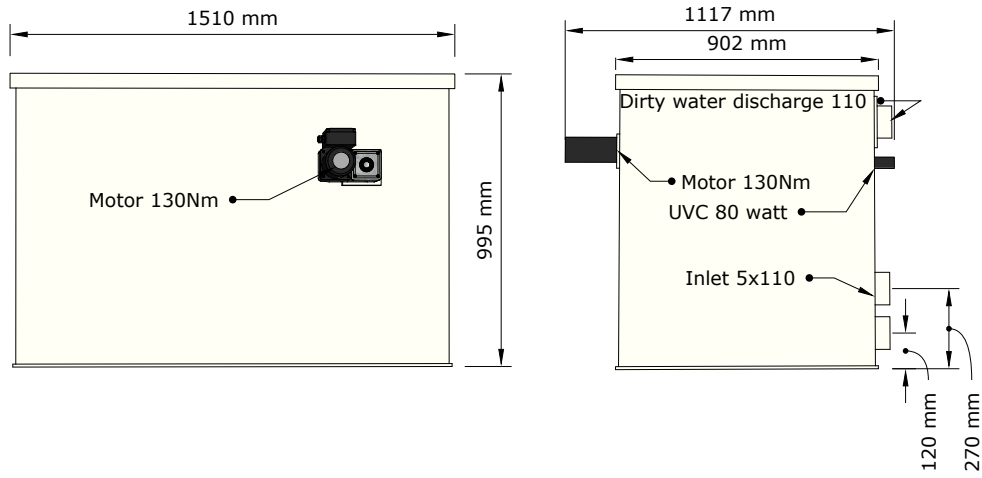

FILTREAU™
EXCELLENT

WMC21CDG	COMBI DRUM 30/50
----------	------------------



Download online

EXCELLENT LINE

Dimensions WMC21CDT Combi Drum 30/50 Trickle

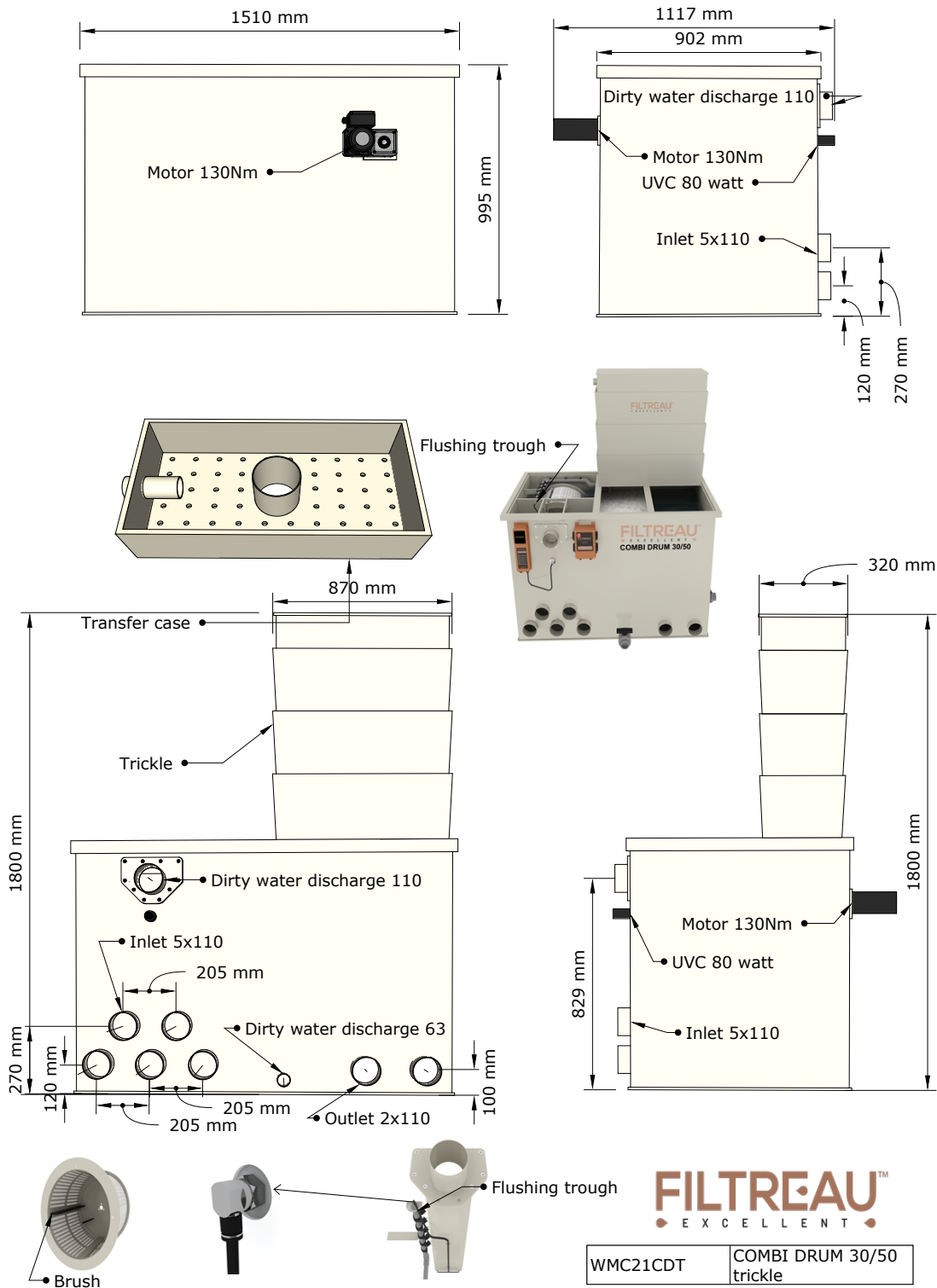

[Download online](#)

Dimensions WMC22CDG 50/70 Gravity

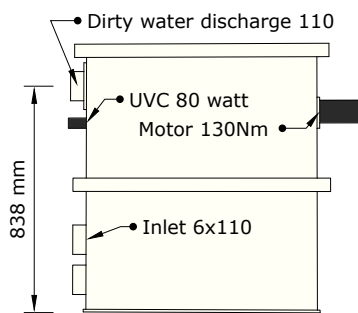
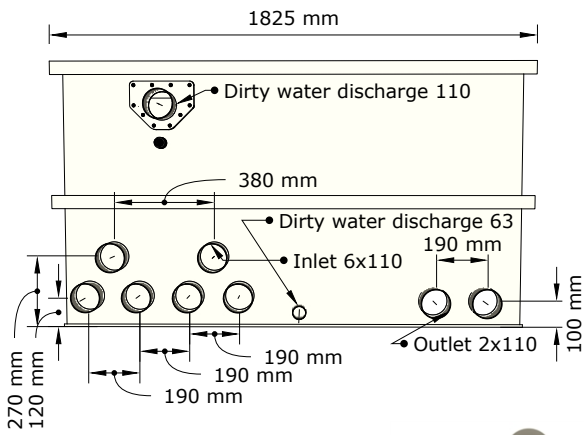
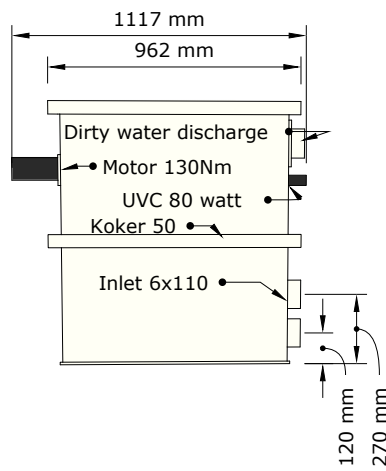
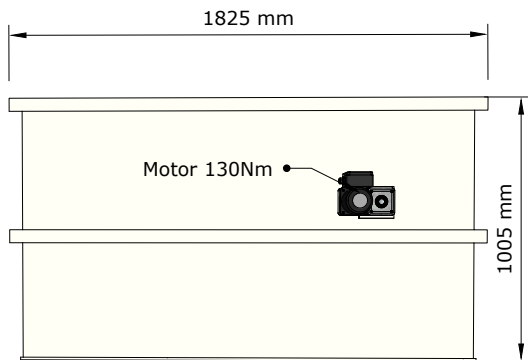

FILTREAU
EXCELLENT

WMC22CDG

COMBI DRUM 50/70



Download online

EXCELLENT LINE

Dimensions WMC22CDP 50/70 Pump

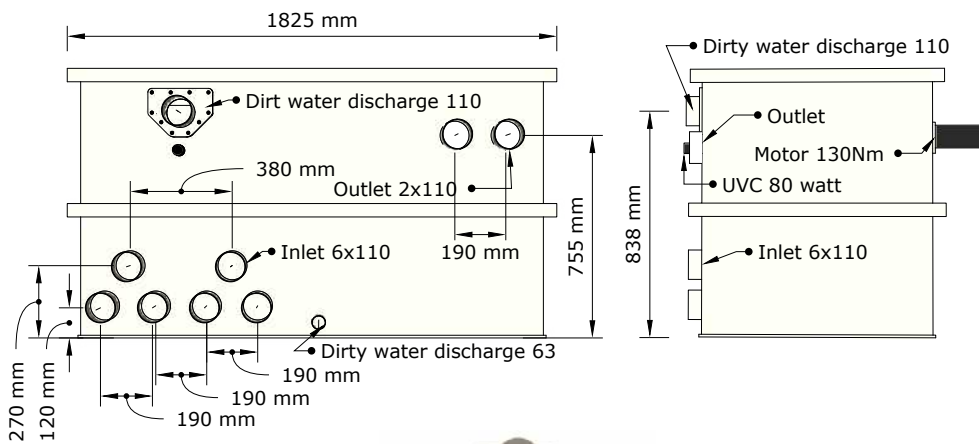
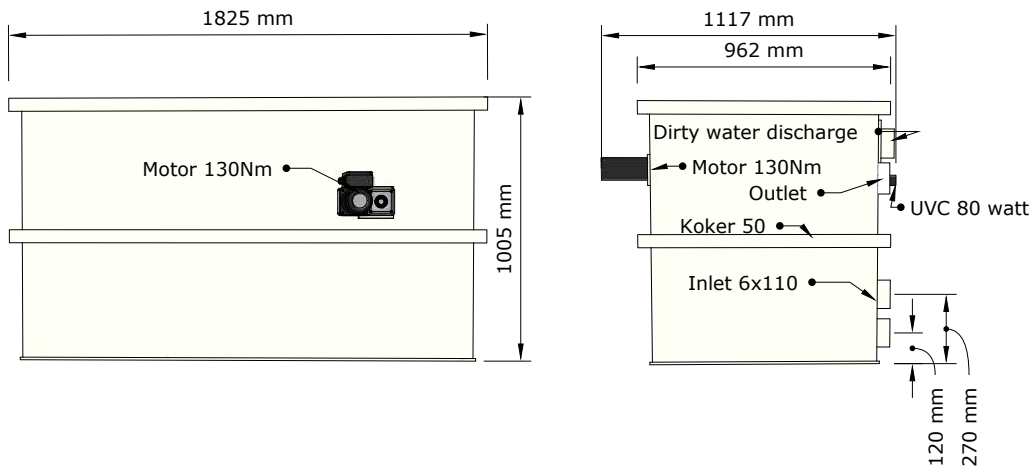

FILTREAU™
EXCELLENT

WMC22CDP COMBI DRUM 50/70



[Download online](#)

Dimensions WMC22CDT Combi Drum 50/70 Trickle

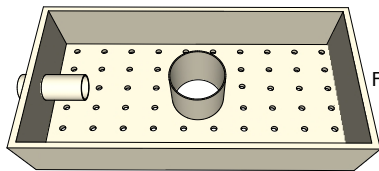
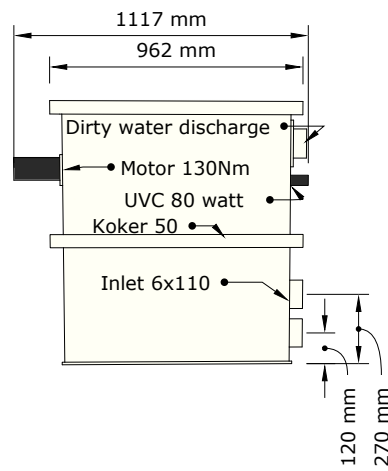
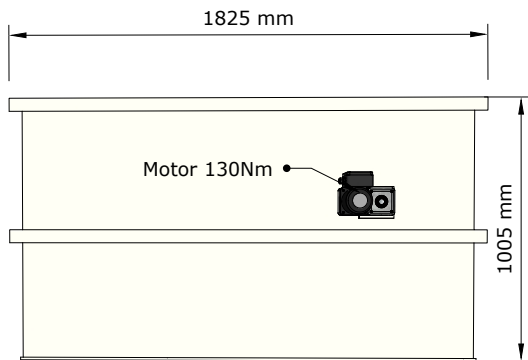

Flushing trough

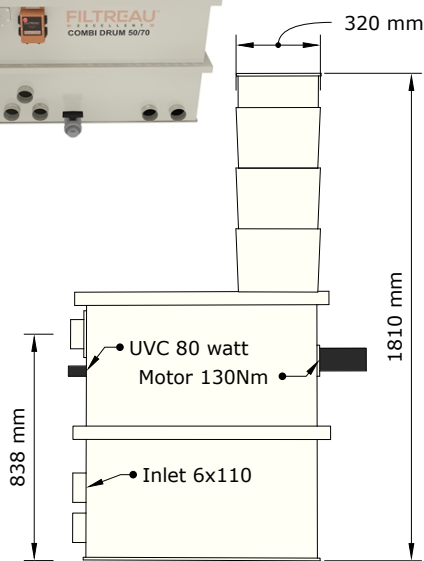
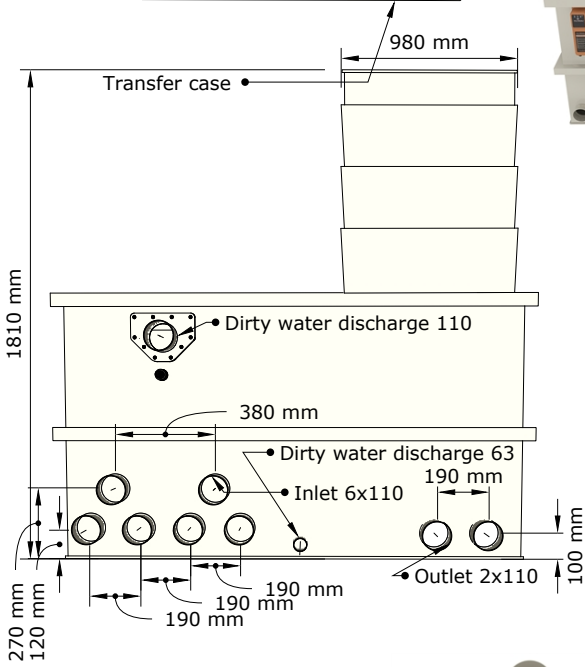

Brush

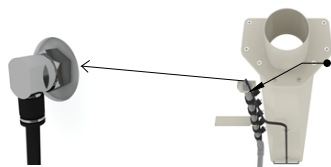

Flushing trough

FILTREAU™
EXCELLENT

WMC22CDT	COMBI DRUM 50/70 trickle
----------	-----------------------------



Download online

EXCELLENT LINE

Dimensions WMC23CDG Combi Drum 60/80 XL Gravity

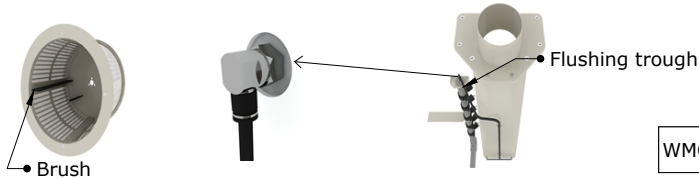
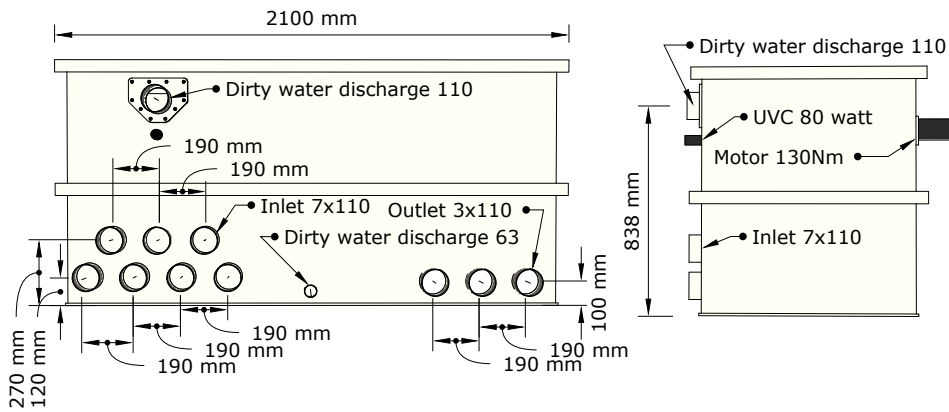
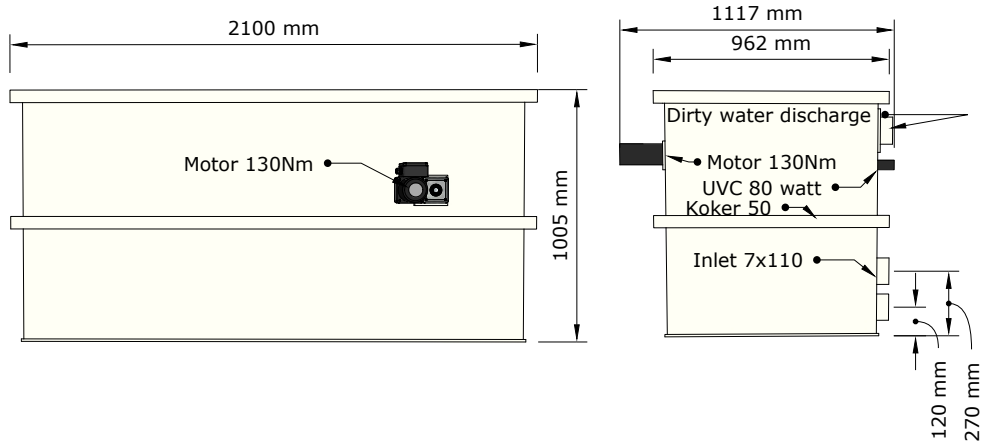

FILTREAU™
EXCELLENT

WMC23CDG	COMBI DRUM 60/80 XL
----------	---------------------



Download online

Dimensions WMC23CDP Combi Drum 60/80 XL Pump

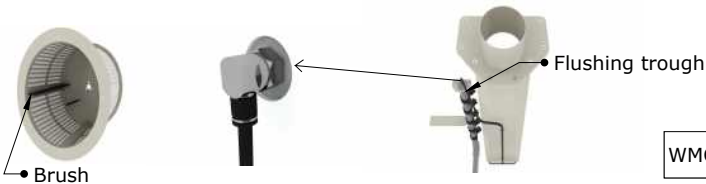
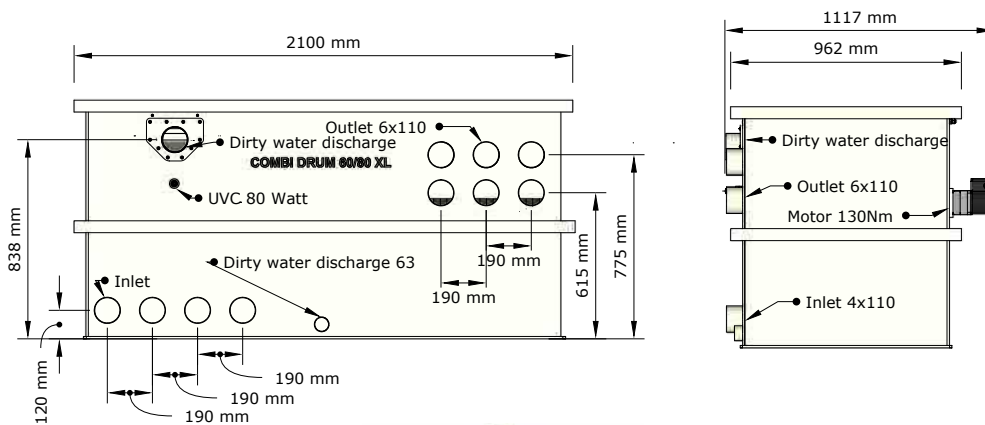
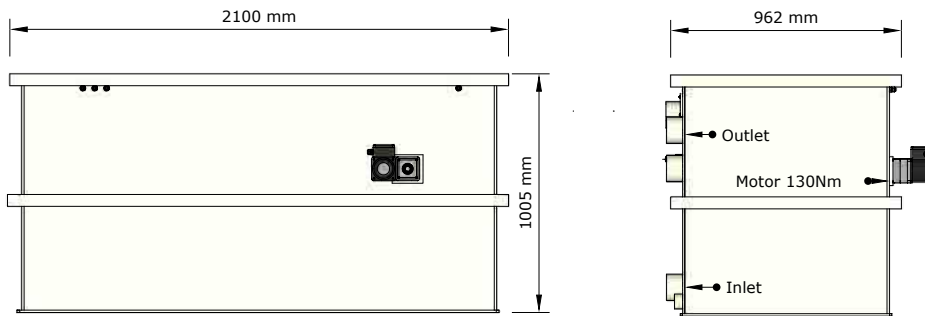

FILTREAU
EXCELLENT

WMC23CDP

COMBI DRUM 60/80 XL



Download online

Dimensions WMC24CDG Combi Drum 80/100 XXL Gravity

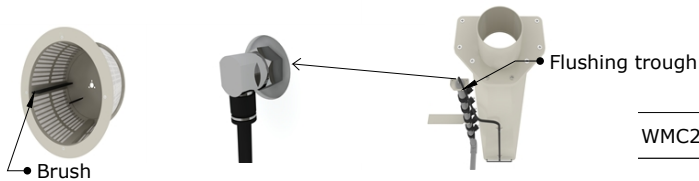
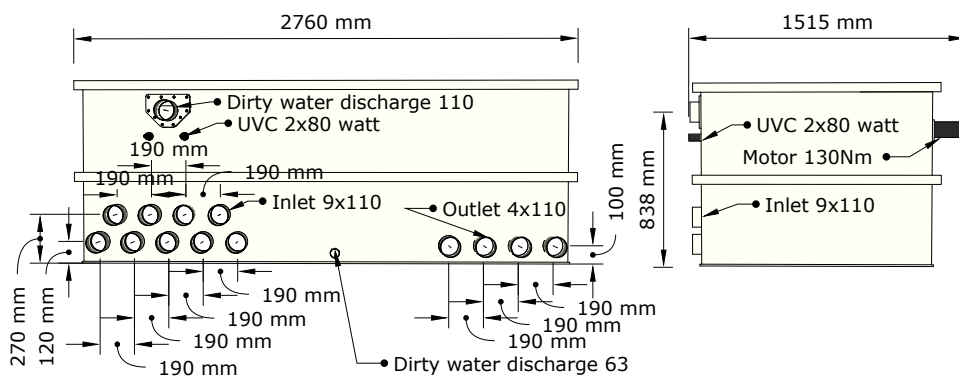
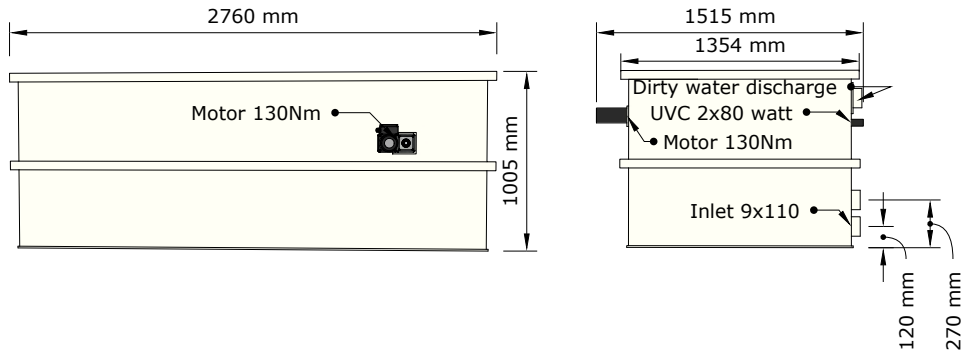

FILTREAU
EXCELLENT

WMC24CDG

COMBI DRUM 80/100
XXL



Download online

EXCELLENT LINE

Dimensions WMC24CDP Combi Drum 80/100 XXL Pump

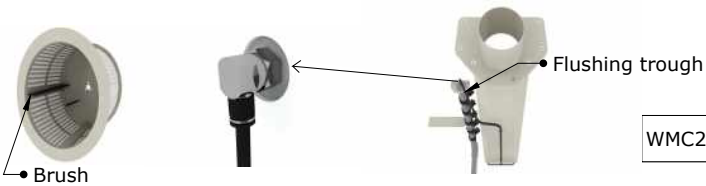
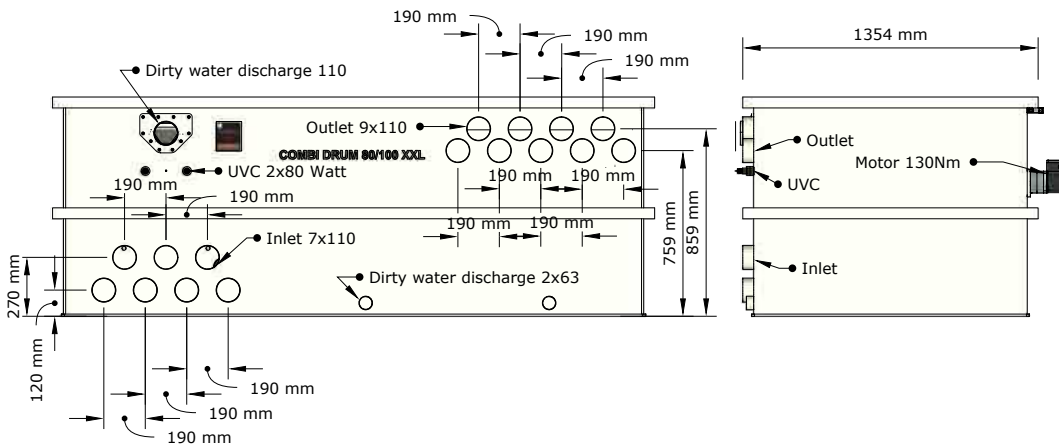
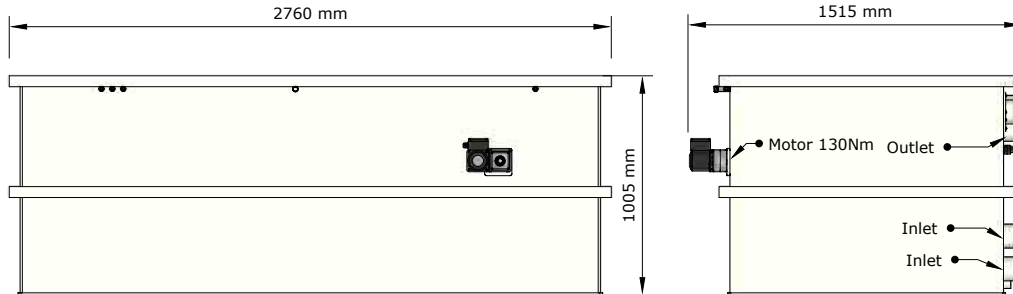

Dimensions WMC24CDT Combi Drum 80/100 XXL Trickle

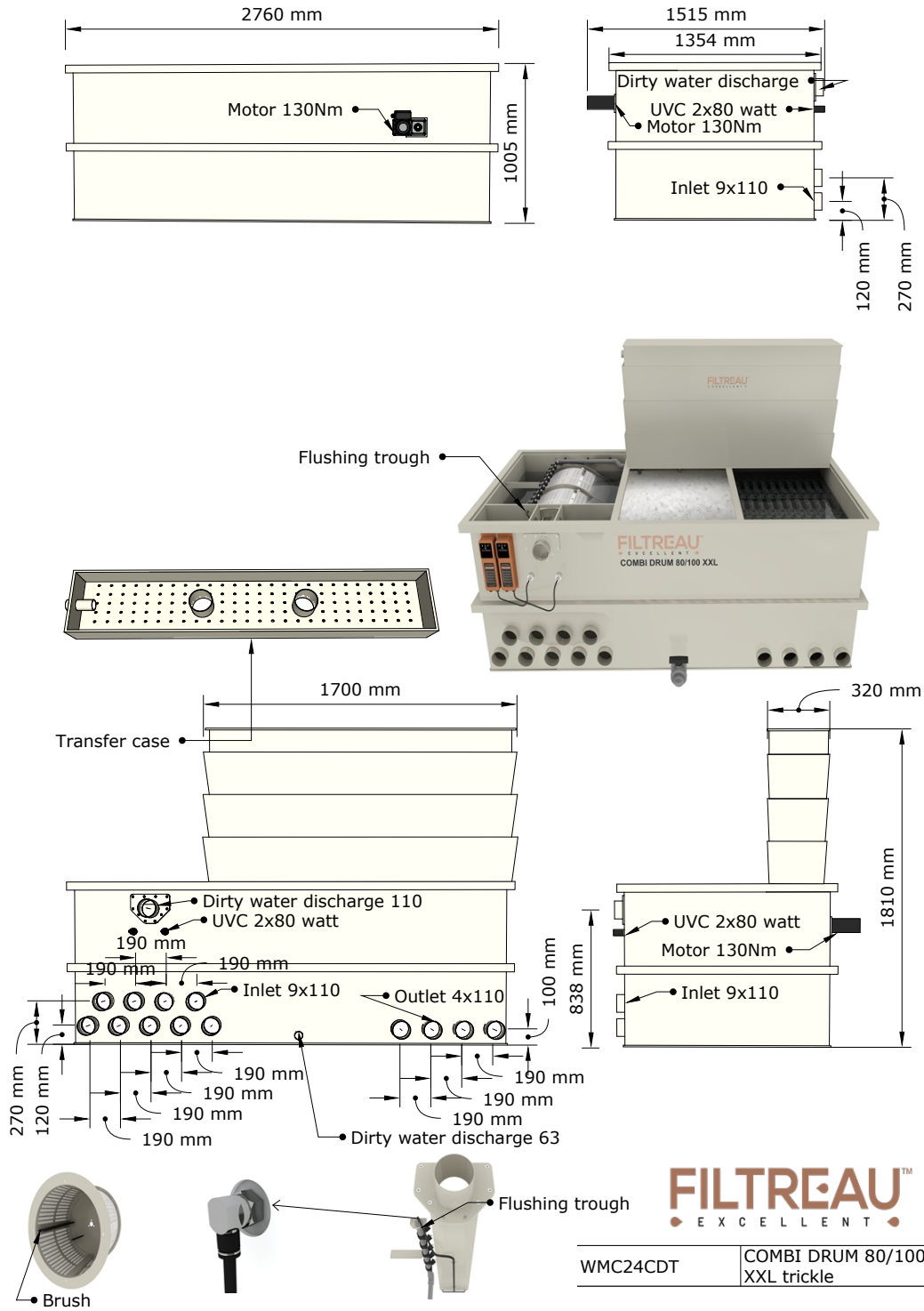

WMC24CDT	COMBI DRUM 80/100 XXL trickle
----------	----------------------------------



Download online

EXCELLENT LINE

Dimensions WMC29ILG Combi Drum 10/15 S Low In Line Gravity

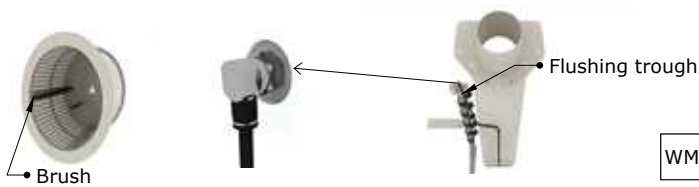
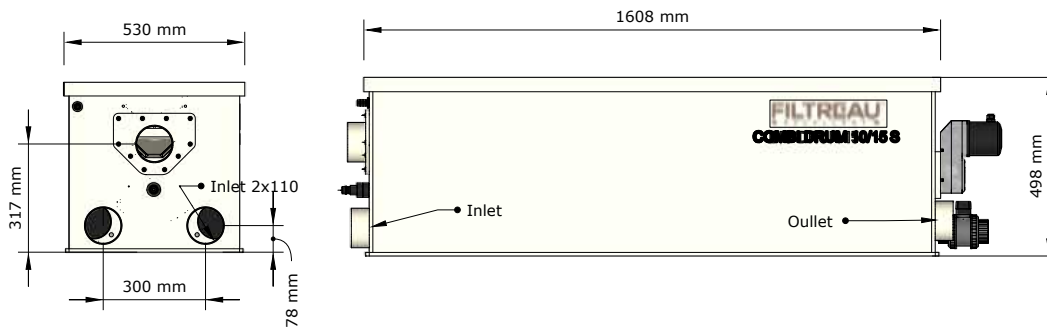
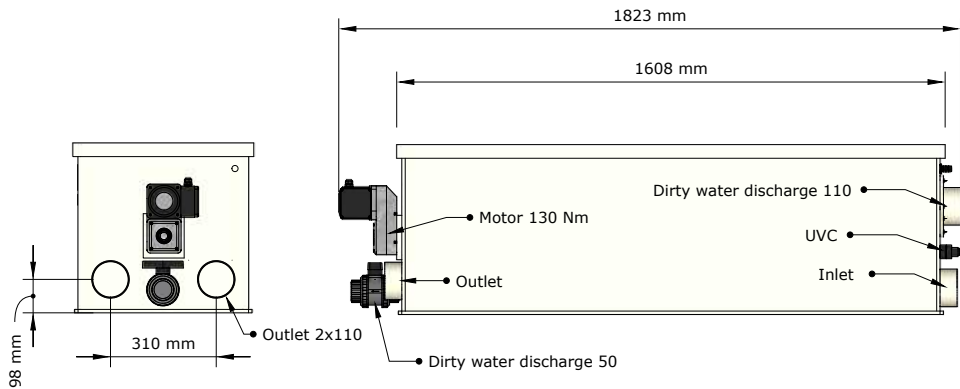

FILTREAU™
EXCELLENT

WMC29ILG	Combi drum 10-15 S
----------	--------------------



[Download online](#)

Dimensions WMC29ILP Combi Drum 10/15 S Low In Line Pump

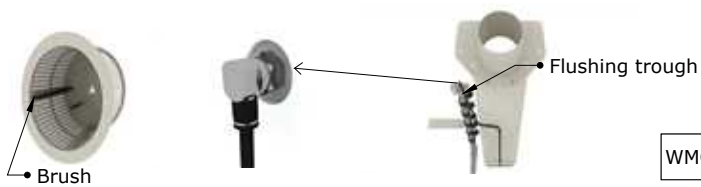
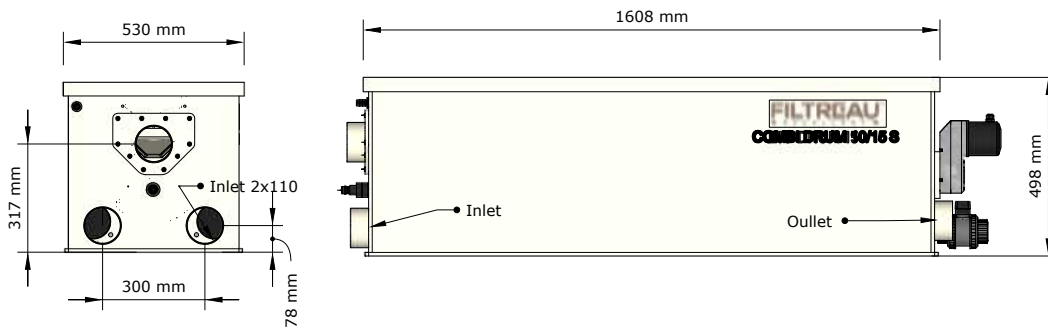
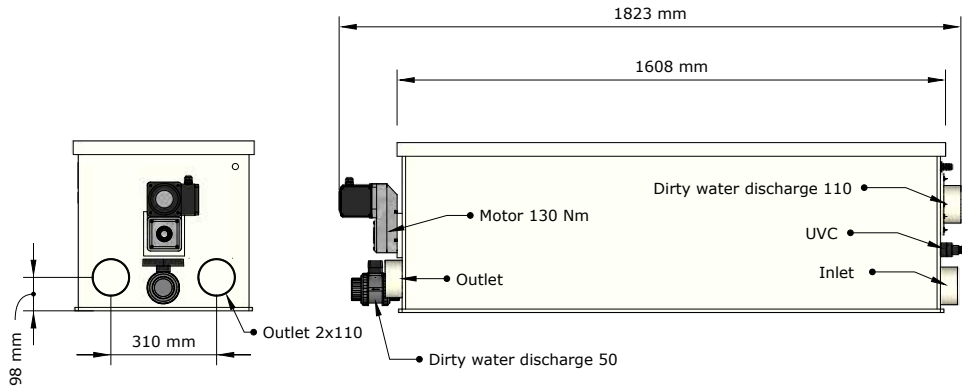

FILTREAU
EXCELLENT

WMC29ILG	Combi drum 10-15 S
----------	--------------------



Download online

EXCELLENT LINE

Dimensions WMC30ILG Combi Drum 25/30 Low In Line Gravity

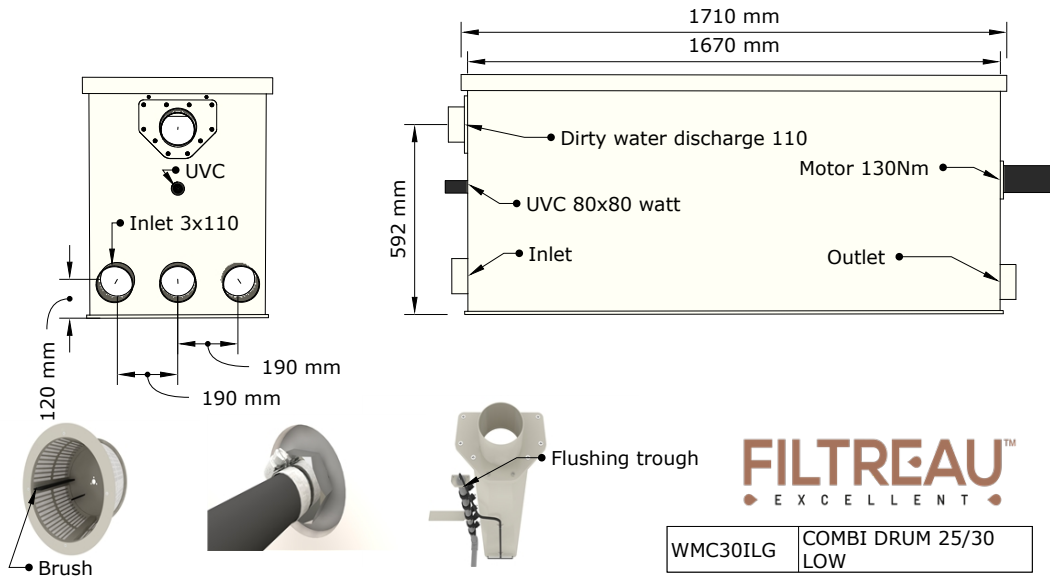
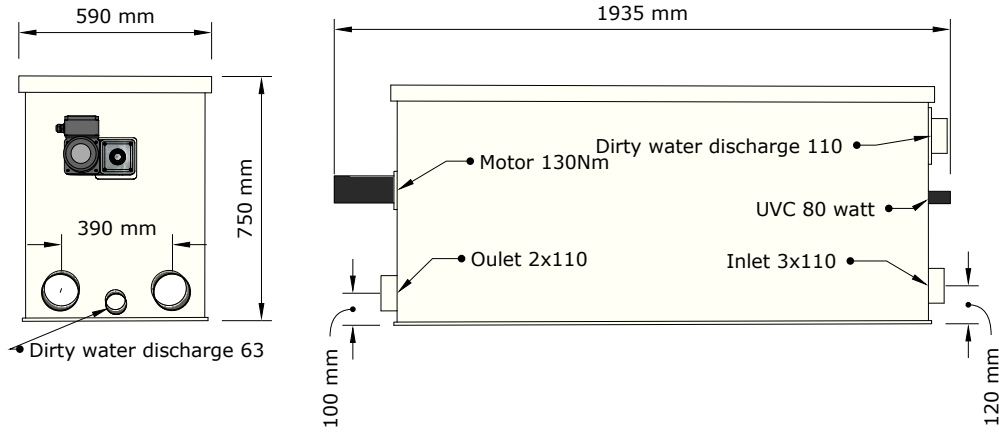

Download online

Dimensions WMC30ILP Combi Drum 25/30 Low In Line Pump

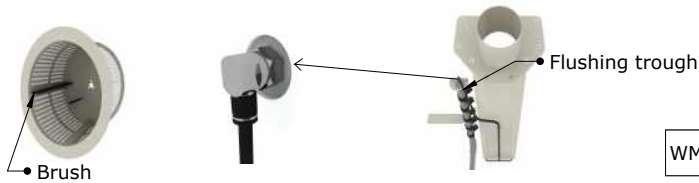
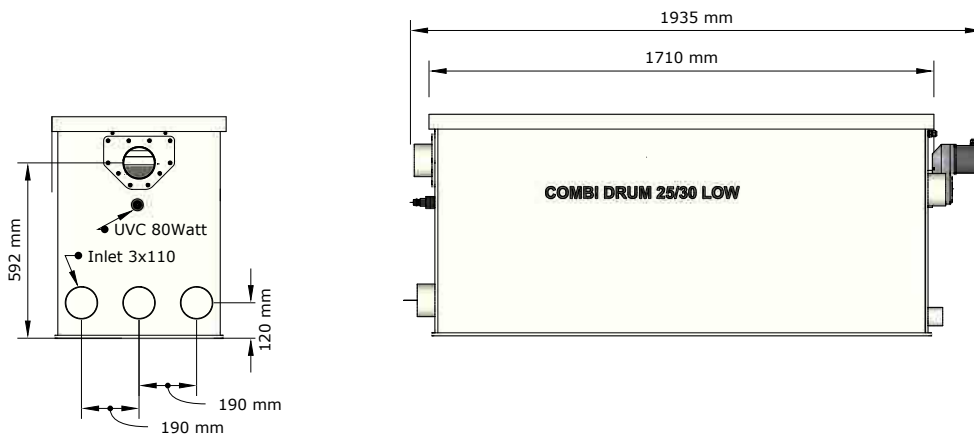
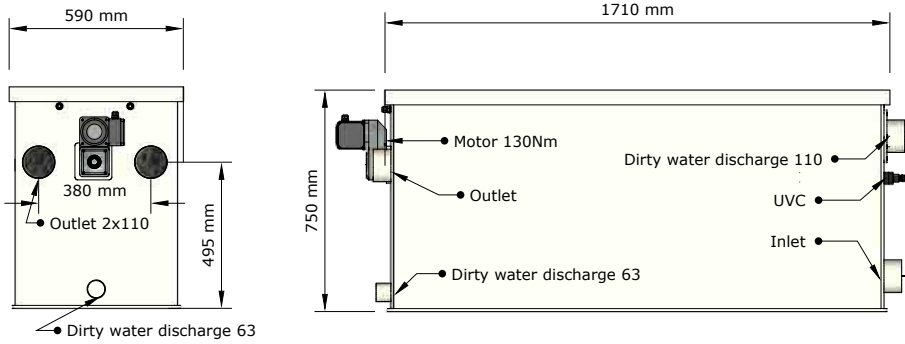

Download online

EXCELLENT LINE

Dimensions WMC30ILT Combi Drum 25/30 Low In Line Trickle

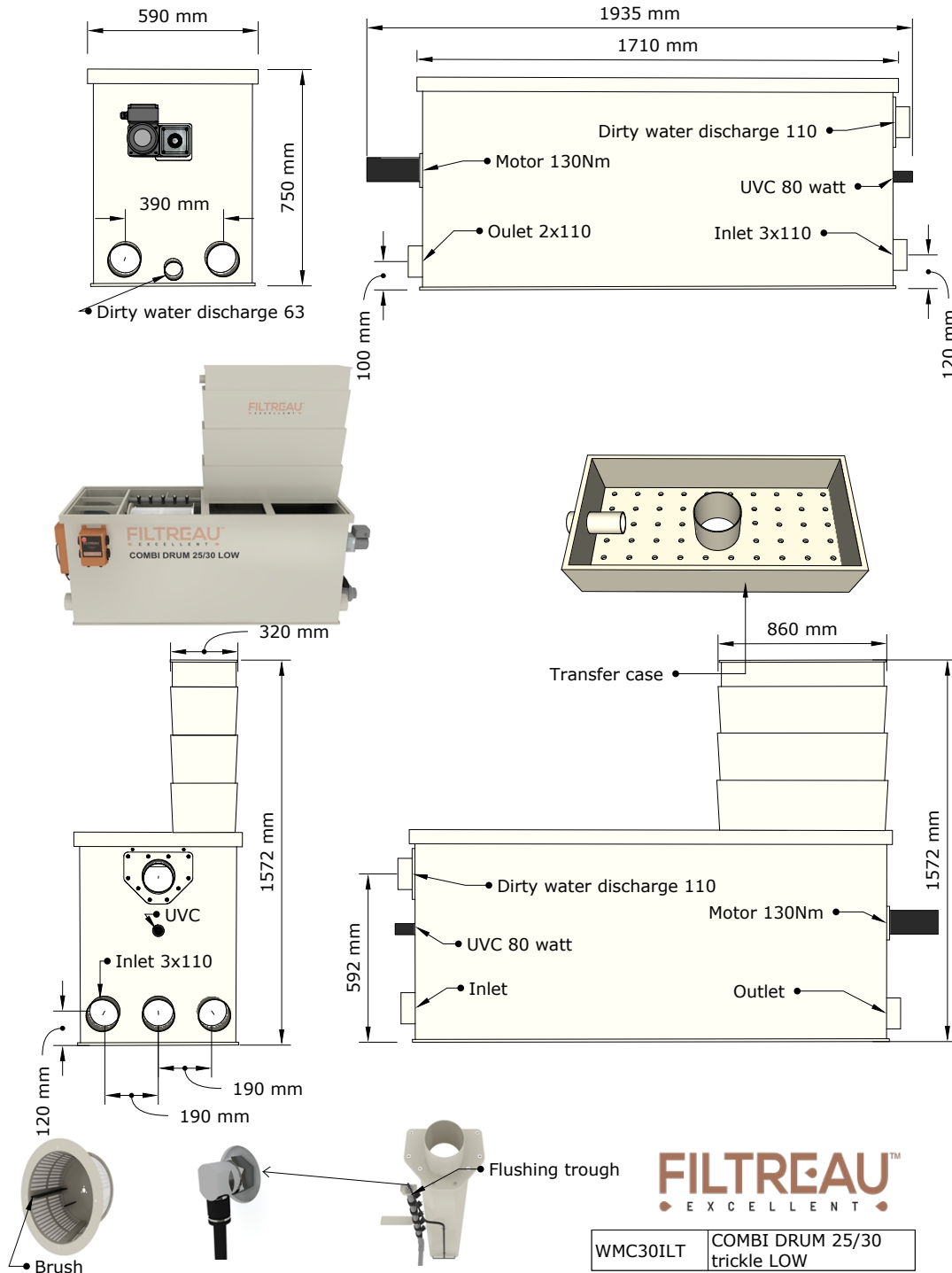

Download online

Dimensions WMC31ILG Combi Drum 30/40 Low In Line Gravity

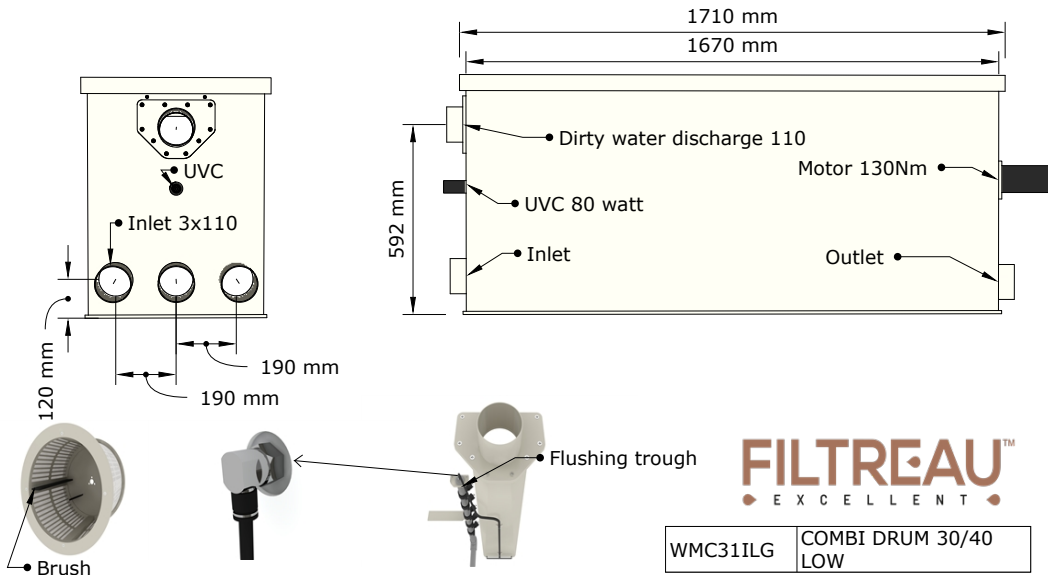
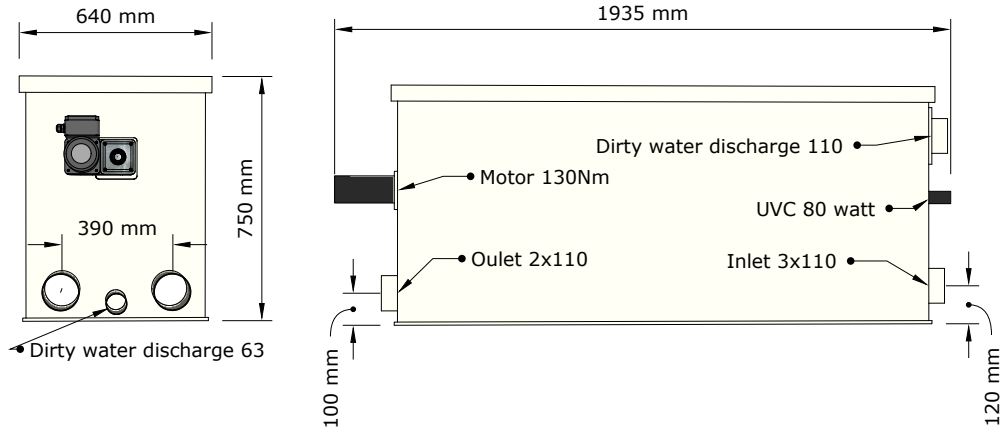

WMC31ILG	COMBI DRUM 30/40 LOW
----------	-------------------------



Download online

EXCELLENT LINE

Dimensions WMC31ILP Combi Drum 30/40 Low In Line Pump

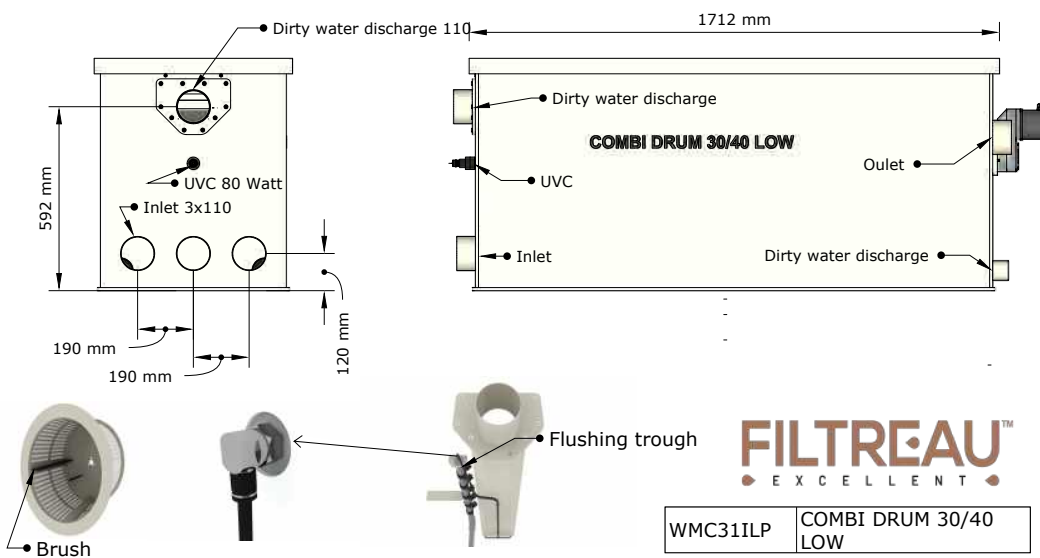
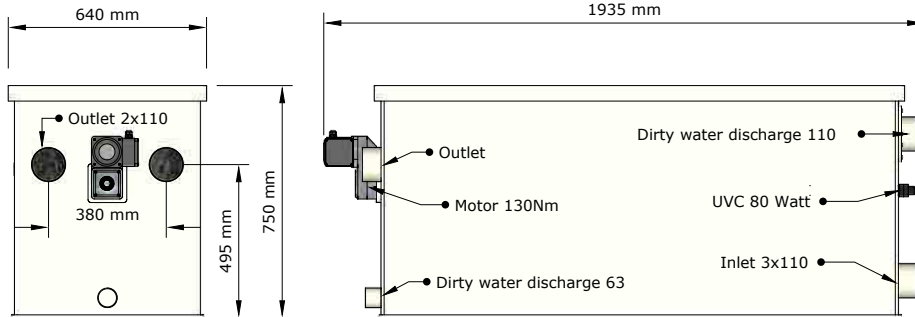

WMC31ILP COMBI DRUM 30/40 LOW



[Download online](#)

Dimensions WMC31ILT Combi Drum 30/40 Low In Line Trickle

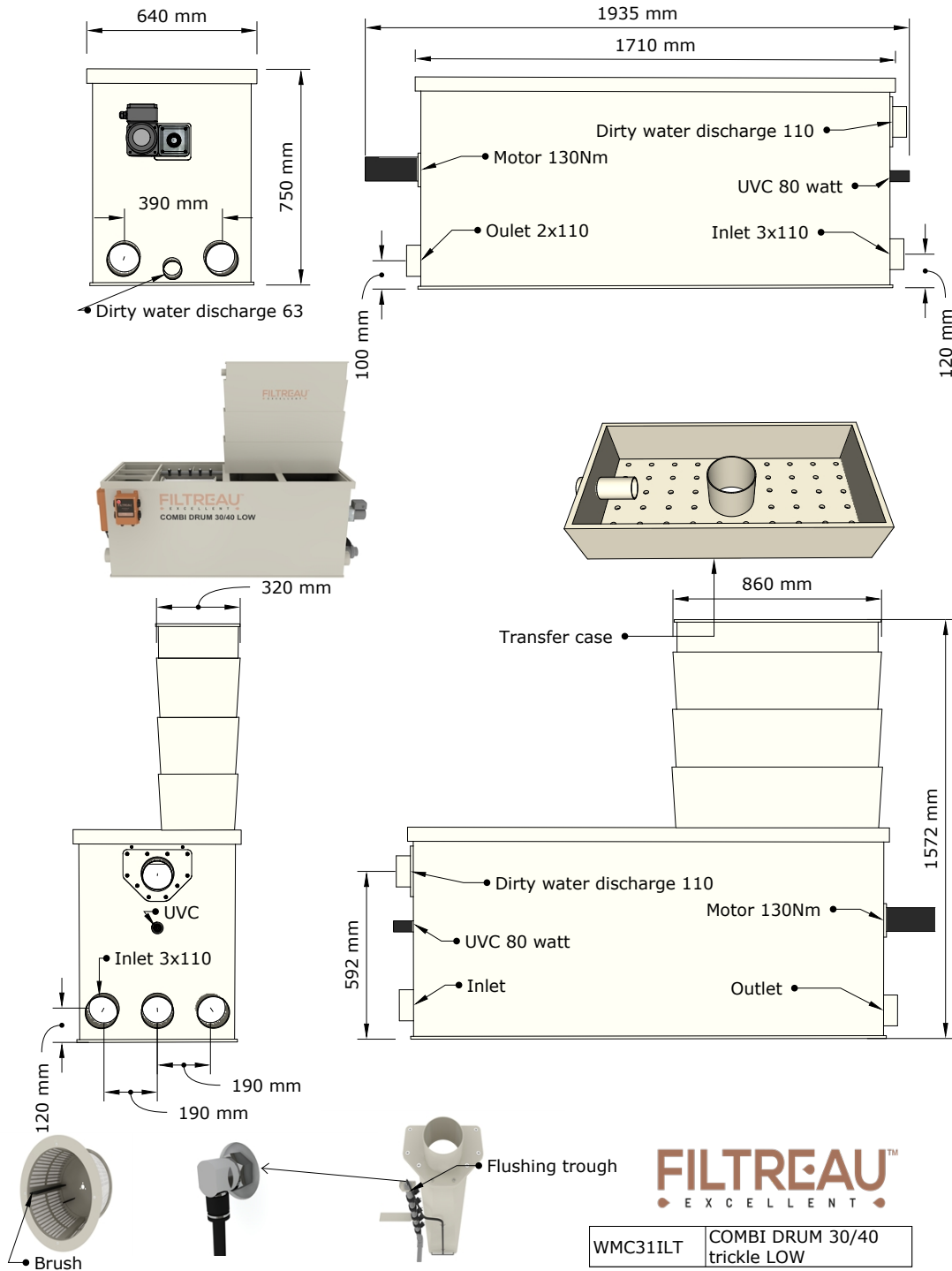

Download online

EXCELLENT LINE

Dimensions WMC32ILG Combi Drum 30/45 L In Line Gravity

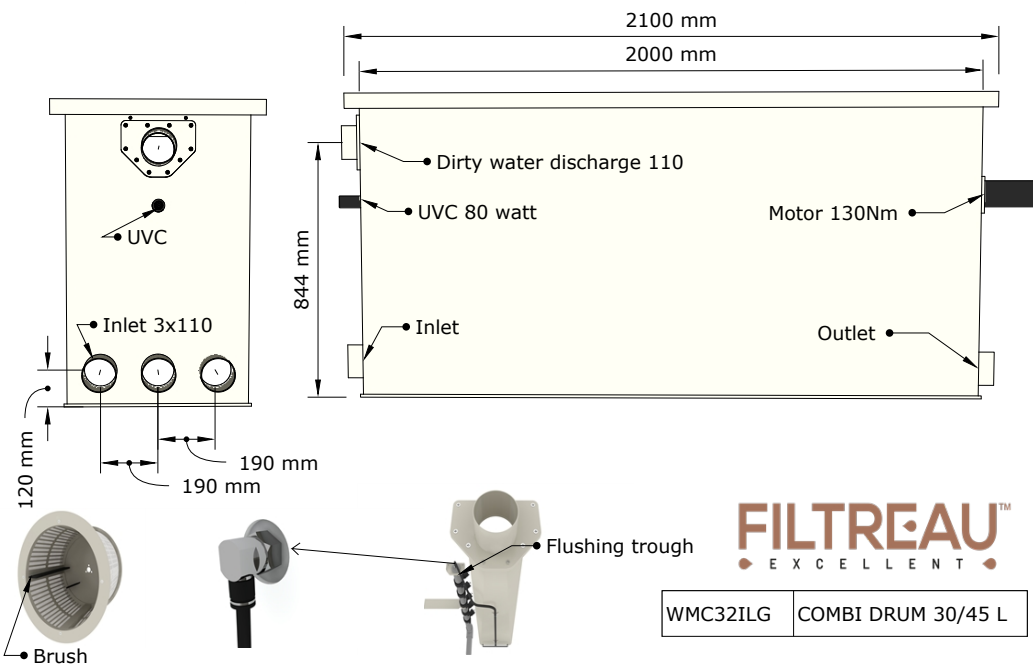
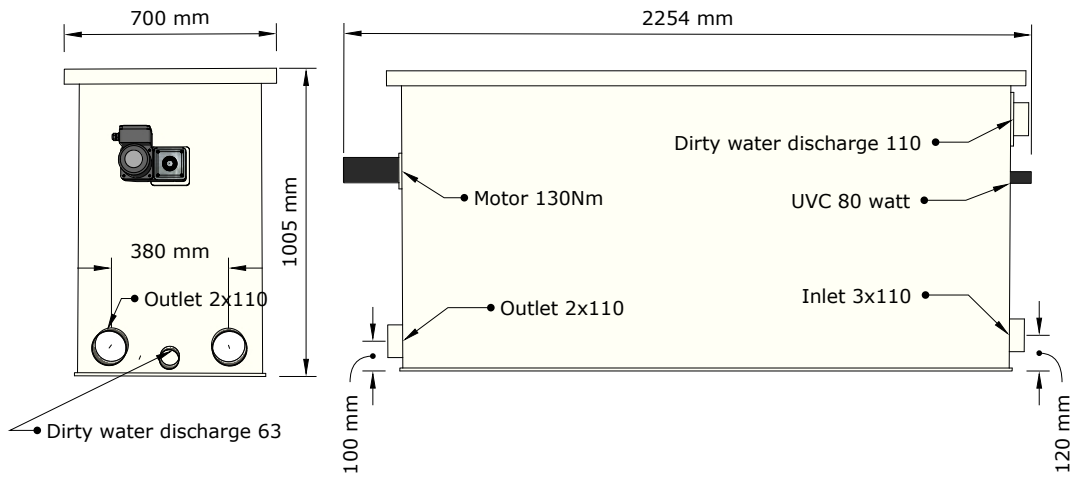

FILTREAU™
EXCELLENT

WMC32ILG COMBI DRUM 30/45 L



Download online

Dimensions WMC32ILP Combi Drum 30/45 L In Line Pump

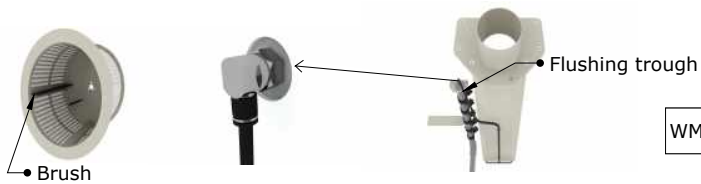
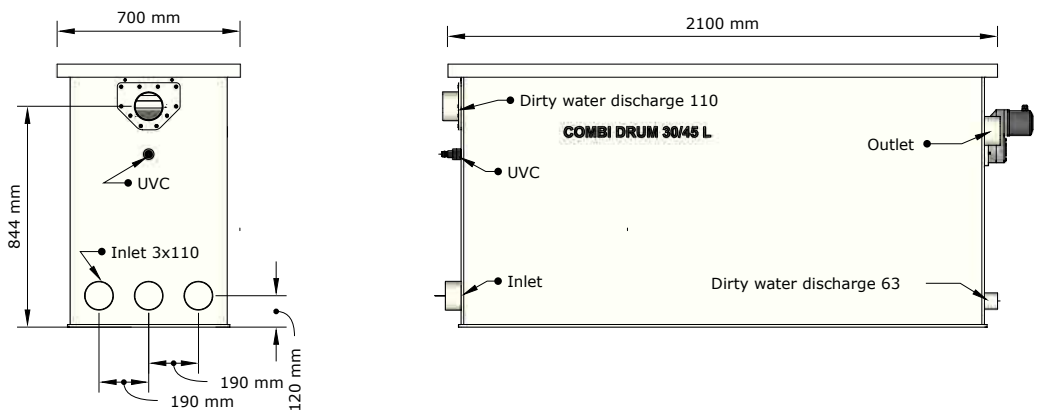
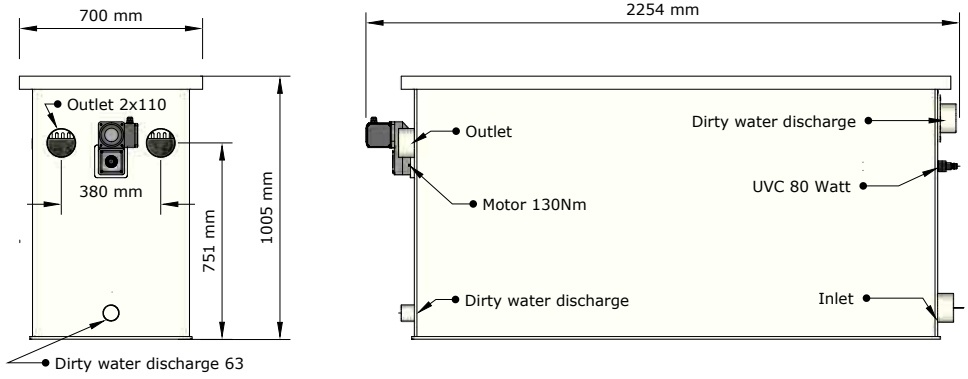

FILTREAU
EXCELLENT

WMC32ILP COMBI DRUM 30/45 L



Download online

EXCELLENT LINE

Dimensions WMC32ILT Combi Drum 30/45 L In Line Trickle

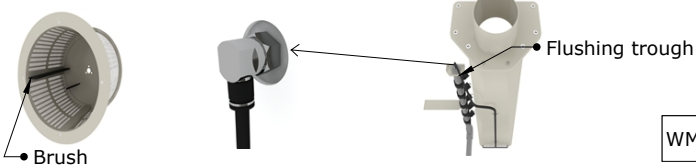
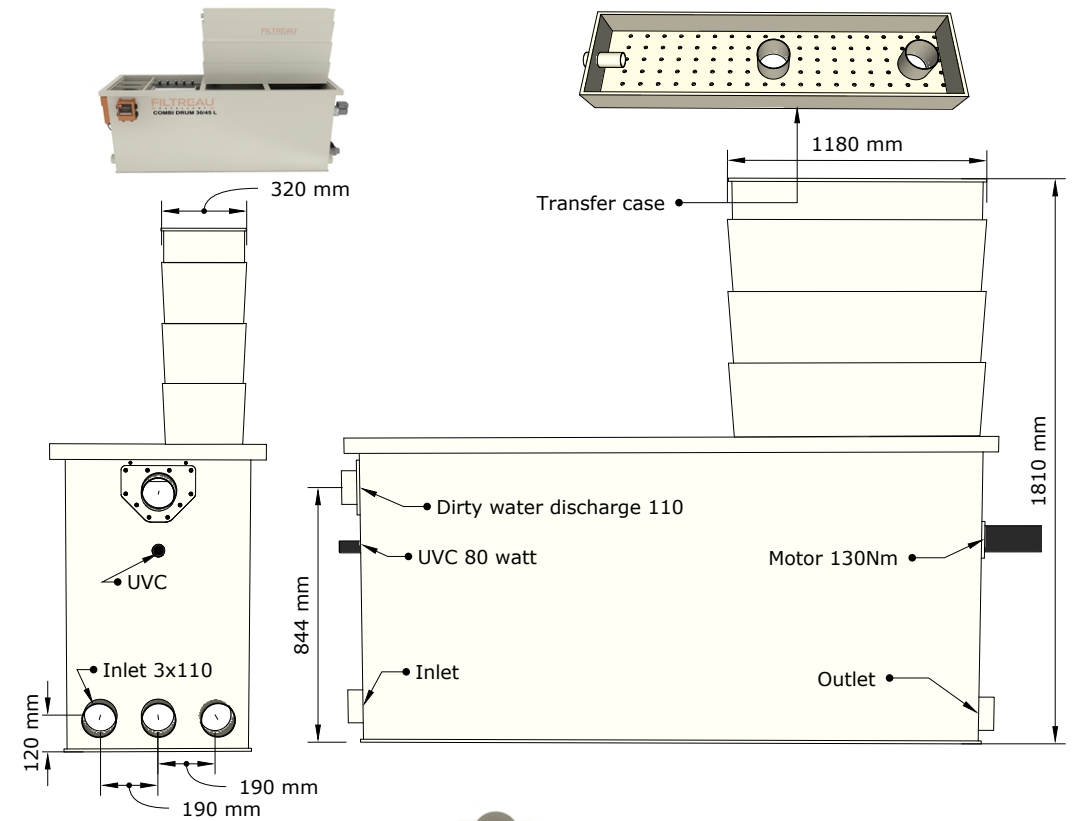
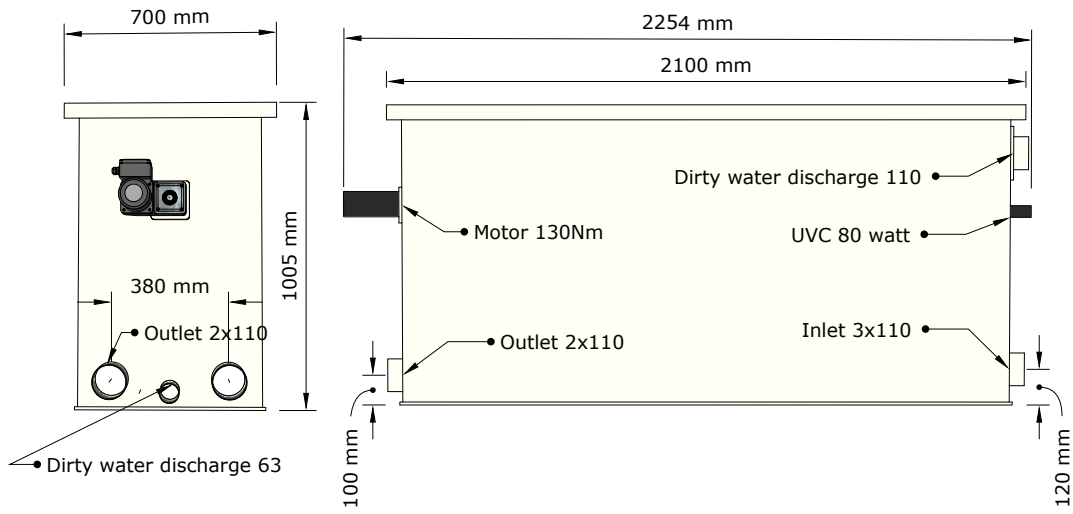

FILTREAU™
EXCELLENT

WMC32ILT COMBI DRUM 30/45 L trickle



Download online

Dimensions WMC33ILG Combi Drum 50/65 XL In Line Gravity

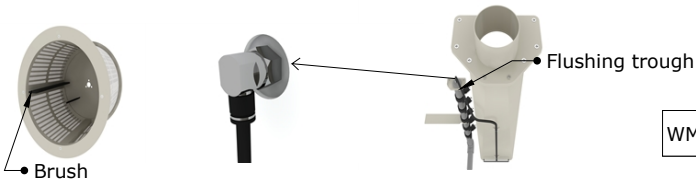
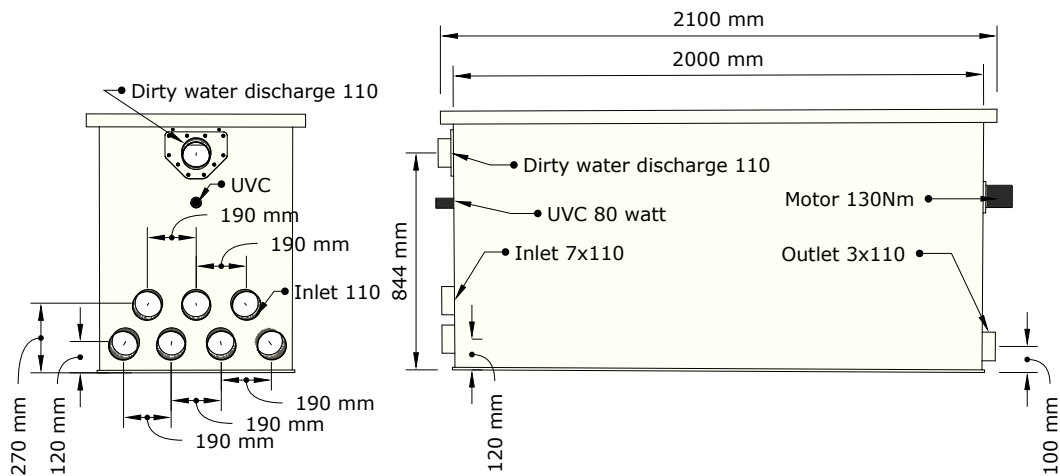
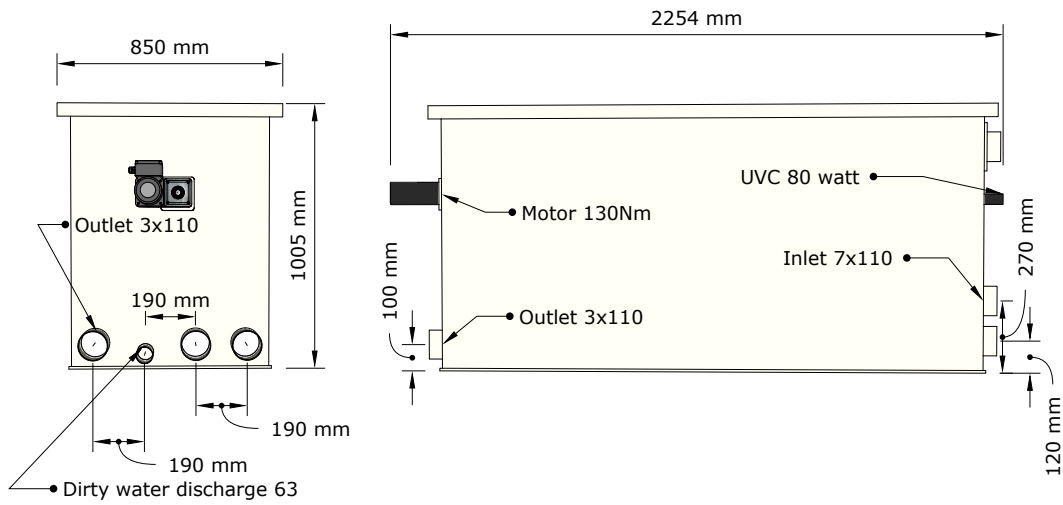

FILTREAU™
EXCELLENT

WMC33ILG COMBI DRUM 50/65 XL



Download online

EXCELLENT LINE

Dimensions WMC33ILP Combi Drum 50/65 XL In Line Pump

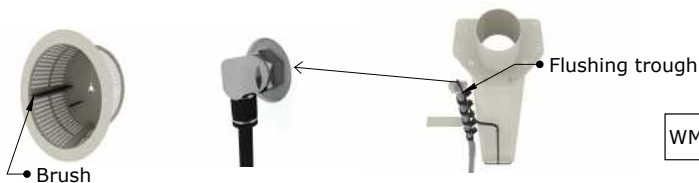
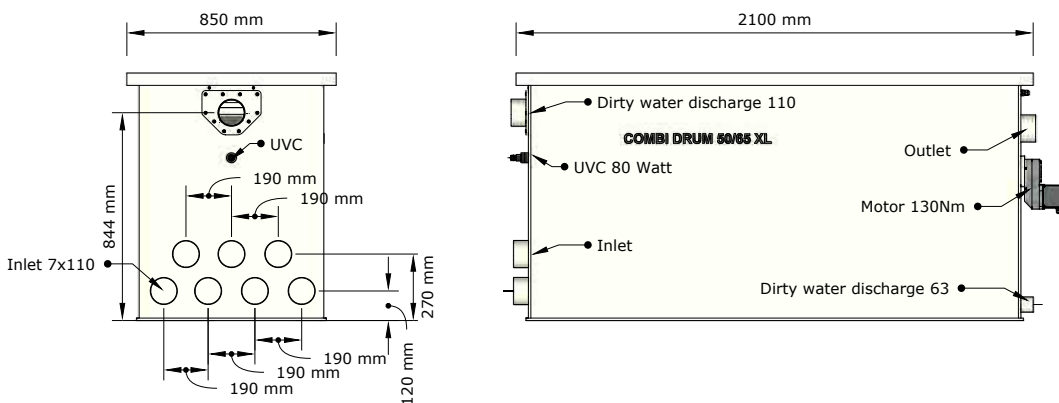
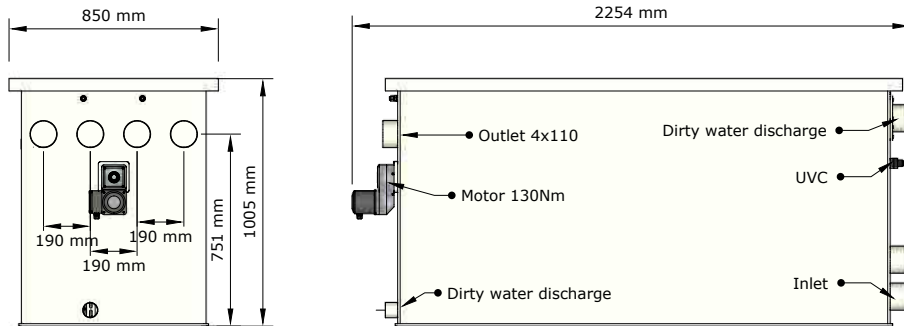

FILTREAU™
EXCELLENT

WMC33ILP COMBI DRUM 50/65 XL



[Download online](#)

Dimensions WMC33ILT Combi Drum 50/65 XL In Line Trickle

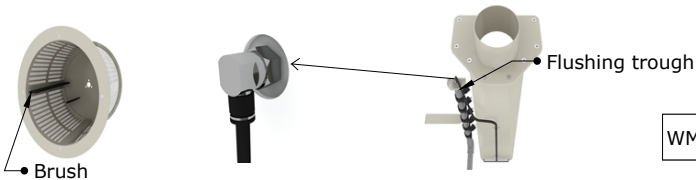
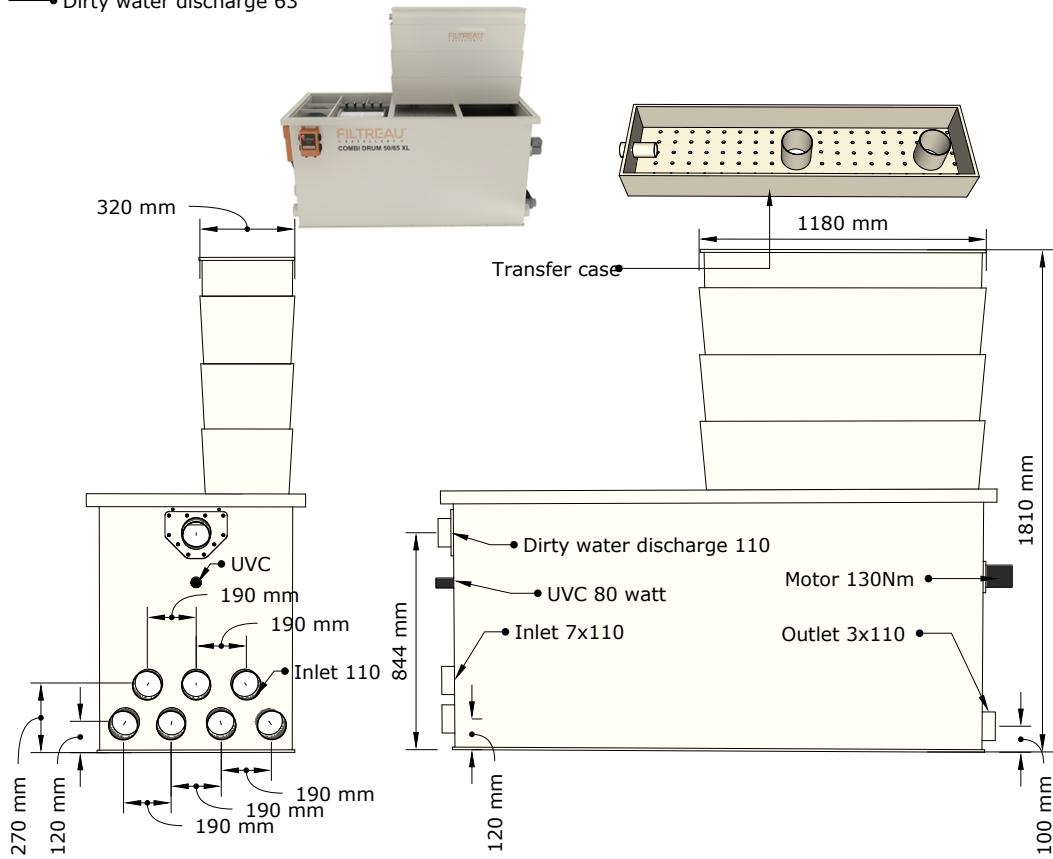
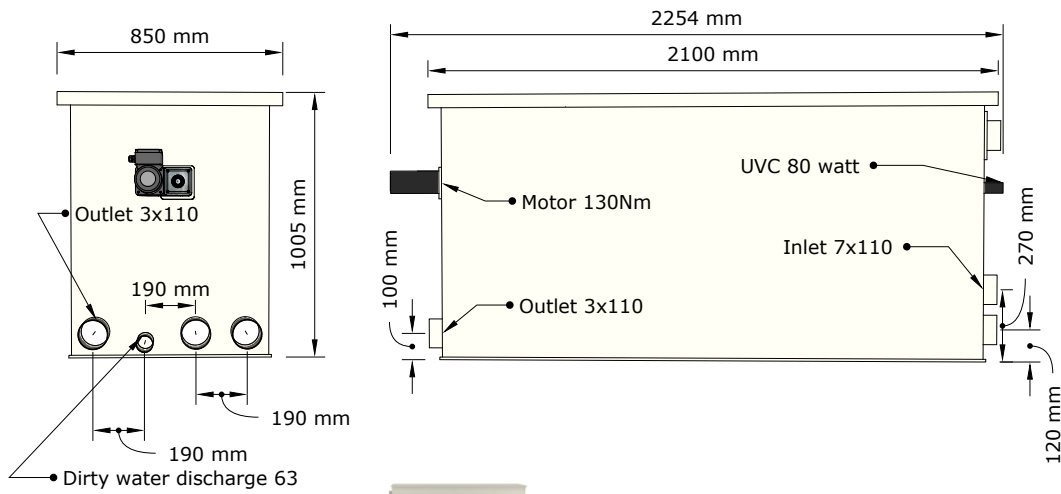

FILTREAU™
EXCELLENT

WMC33ILT	COMBI DRUM 50/65 XL trickle
----------	--------------------------------



Download online

EXCELLENT LINE

Dimensions WMC34ILG Combi Drum 80/100 XXL In Line Gravity

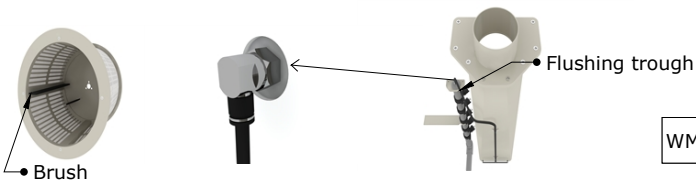
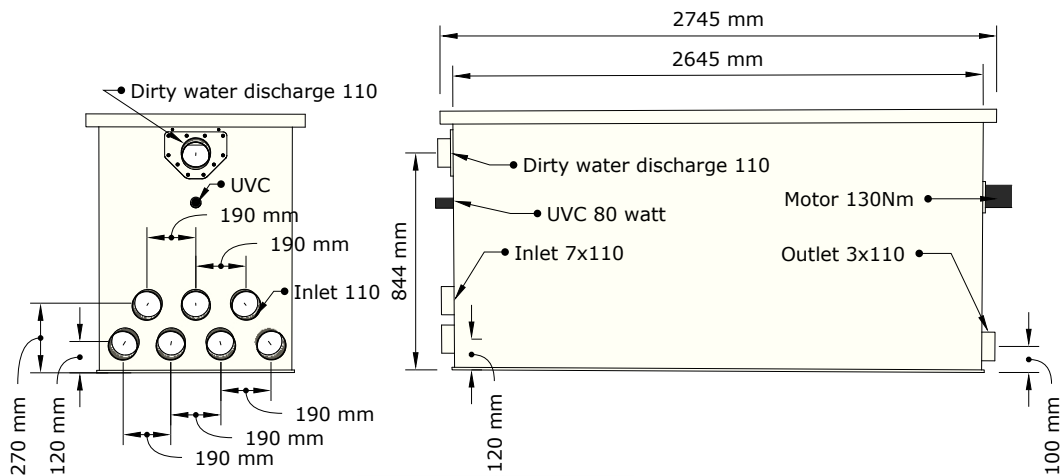
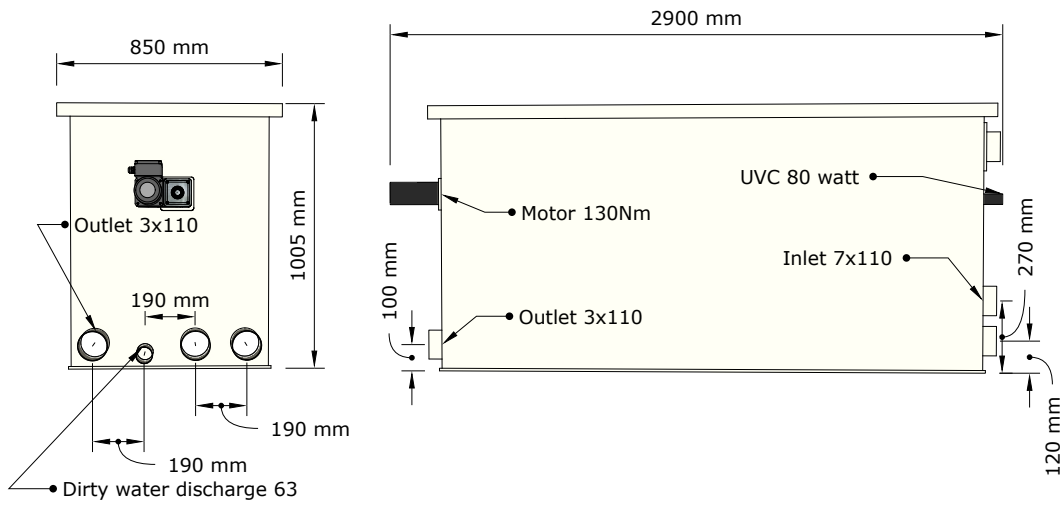

FILTREAU™
EXCELLENT

WMC34ILG	COMBI DRUM 80/100 XXL
----------	--------------------------



[Download online](#)

Dimensions WMC34ILP Combi Drum 80/100 XXL In Line Pump

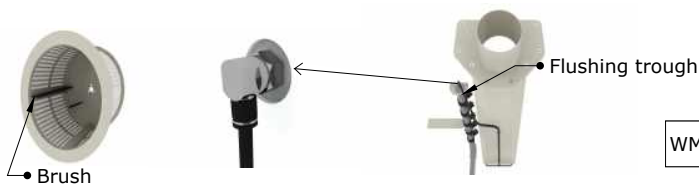
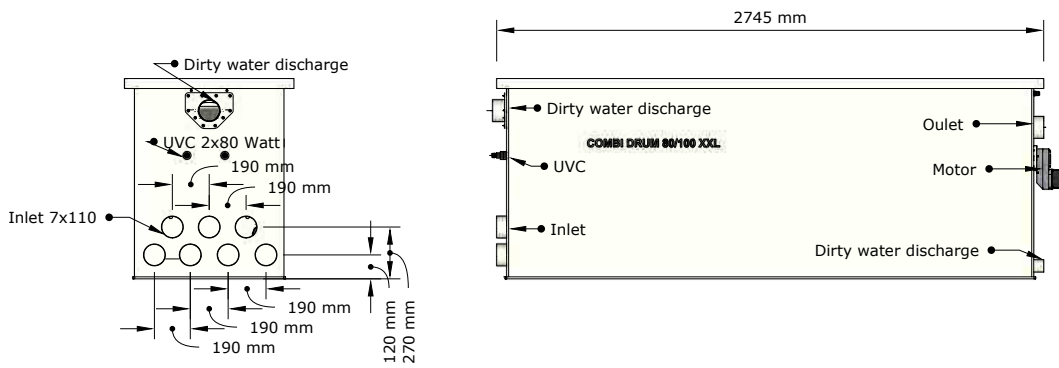
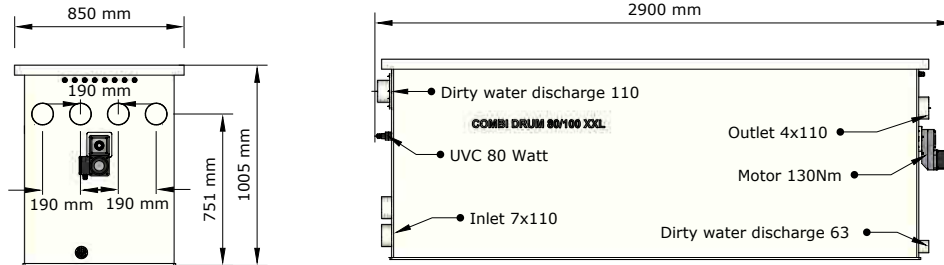

FILTREAU
EXCELLENT

WMC34ILP	COMBI DRUM 80/100 XXL
----------	--------------------------



Download online

EXCELLENT LINE

Dimensions WMC34ILT Combi Drum 80/100 XXL In Line Trickle

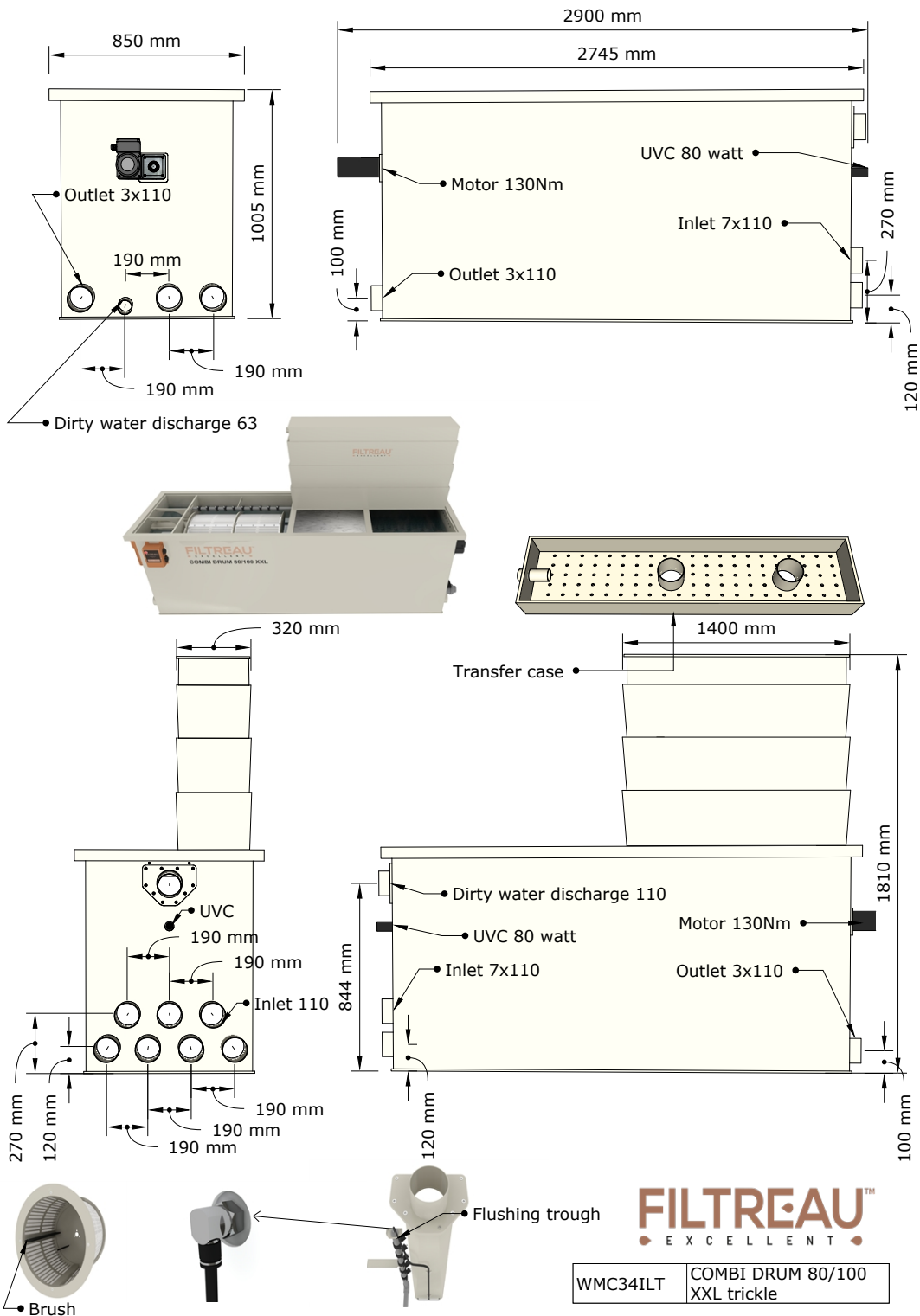

WMC34ILT COMBI DRUM 80/100
XXL trickle



Download online

EXCELLENT LINE

Dimensions WMC38ILB Leaf Catcher B

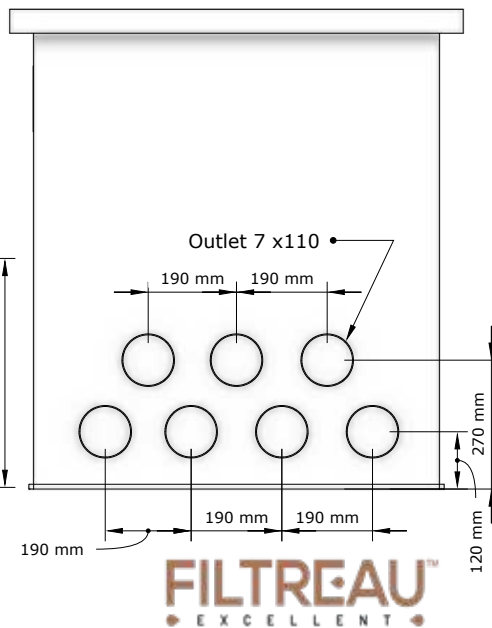
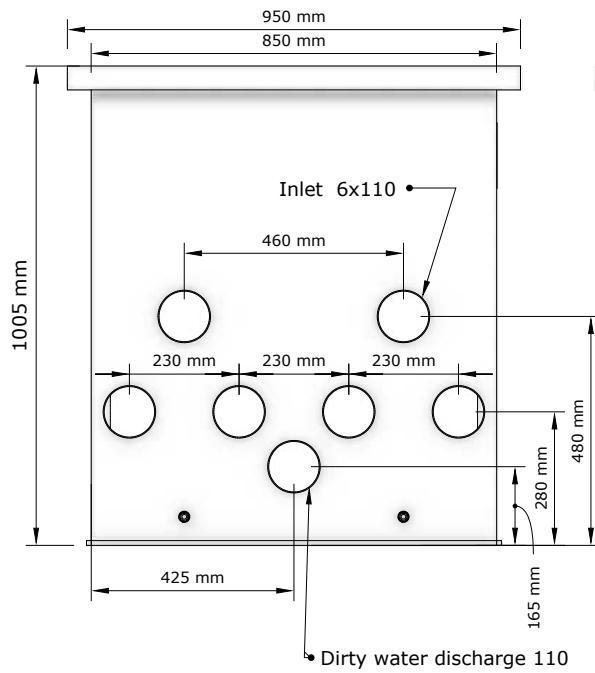
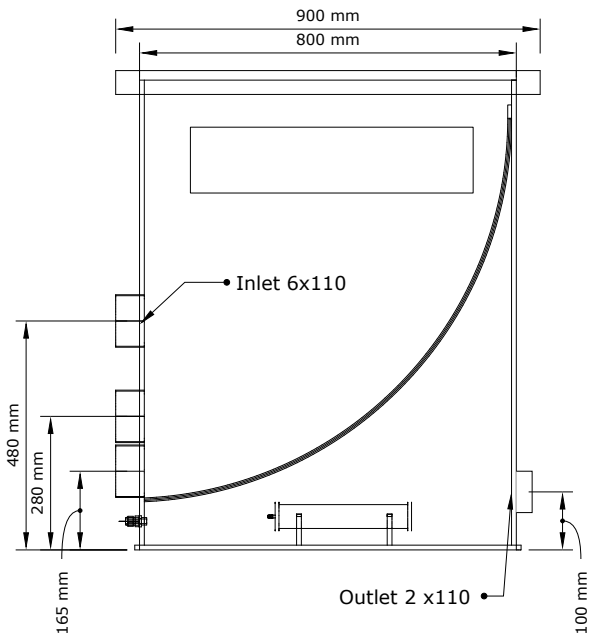

WMC38ILB	Leaf catcher B
----------	----------------



[Download online](#)

Dimensions WMC40ROG Combi Drum 30/50 Rotate Gravity

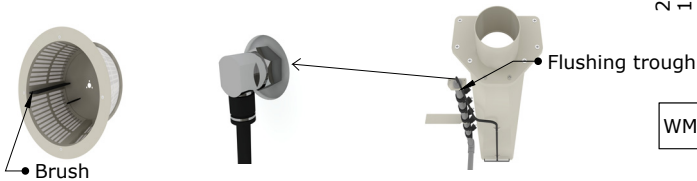
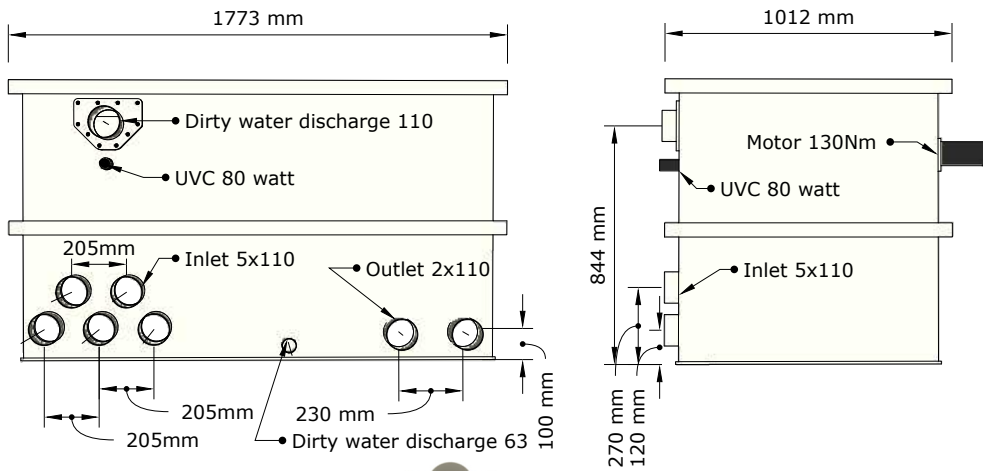
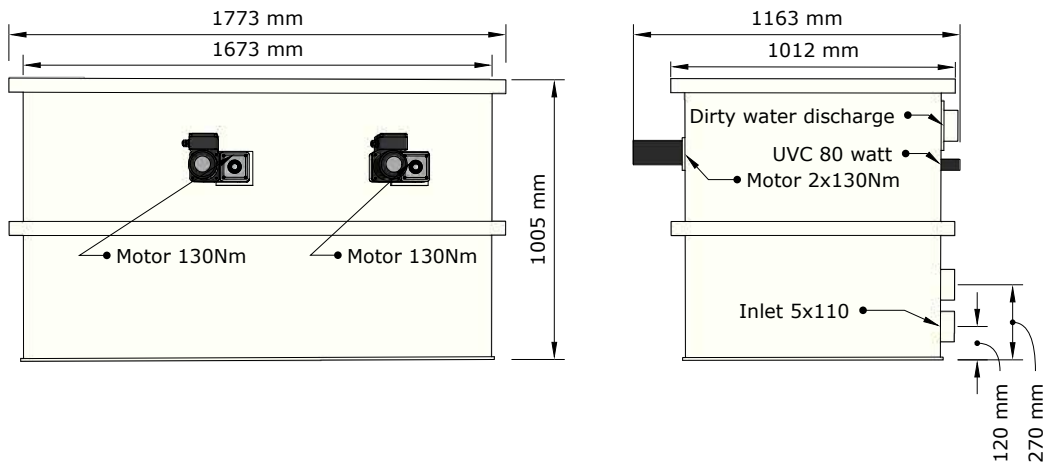

FILTREAU™
EXCELLENT

WMC40ROG	COMBI DRUM 30/50 ROTATE
----------	----------------------------



Download online

EXCELLENT LINE

Dimensions WMC40ROP Combi Drum 30/50 Rotate Pump

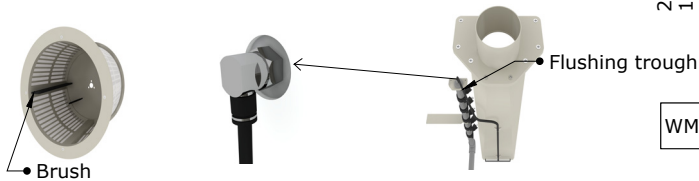
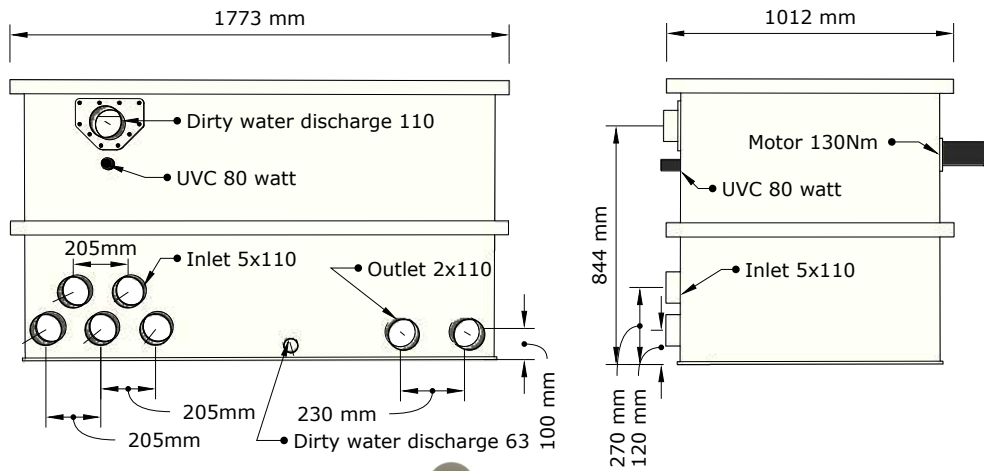
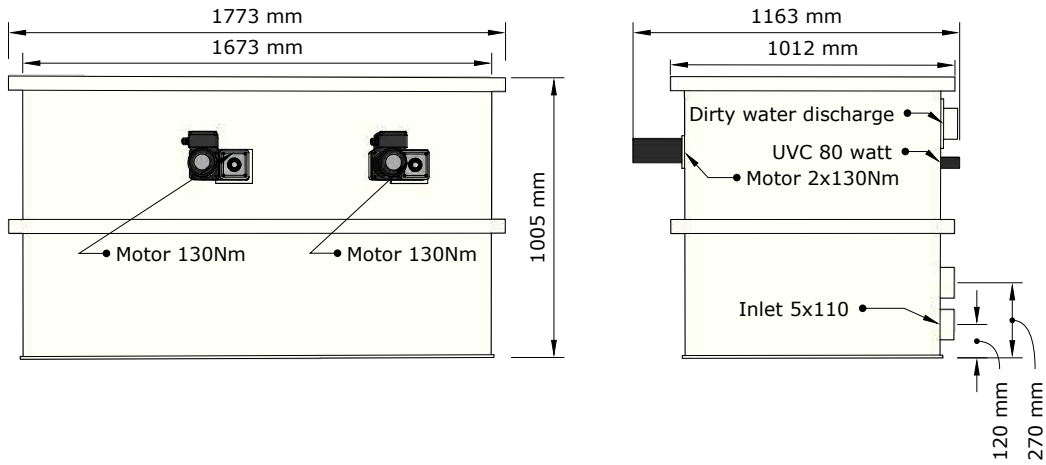

FILTREAU™
EXCELLENT

WMC40ROG COMBI DRUM 30/50 ROTATE



[Download online](#)

Dimensions WMC40ROT Combi Drum 30/50 Rotate Trickle

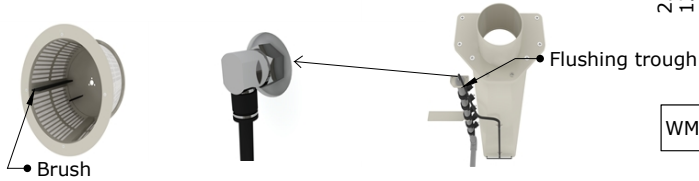
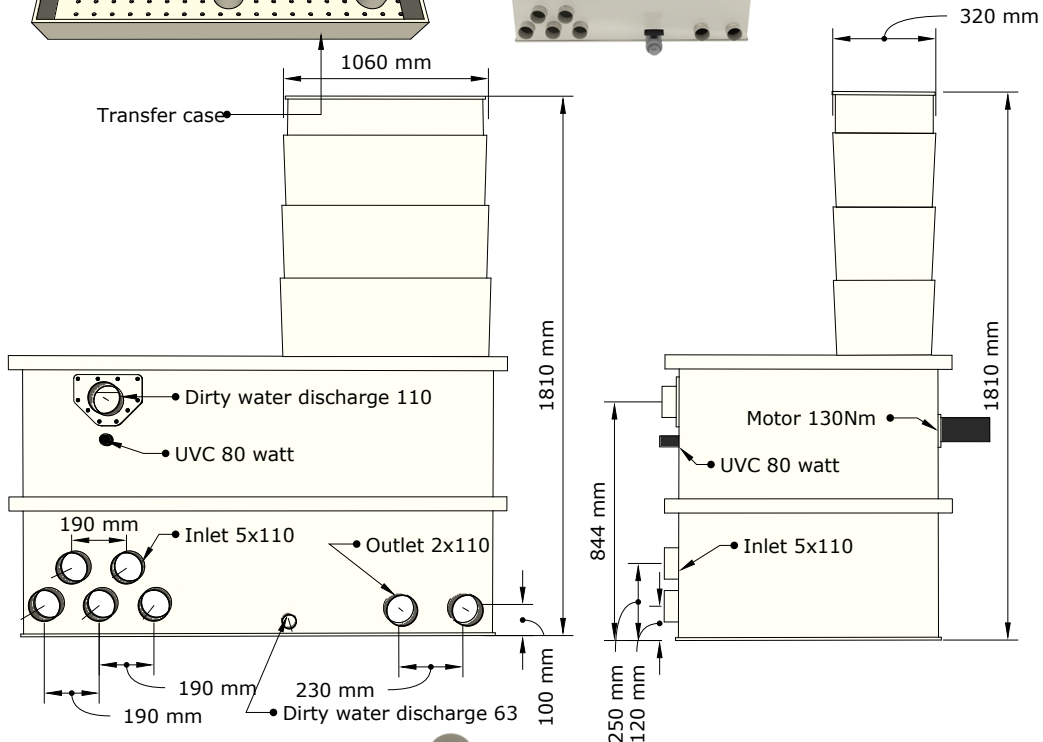
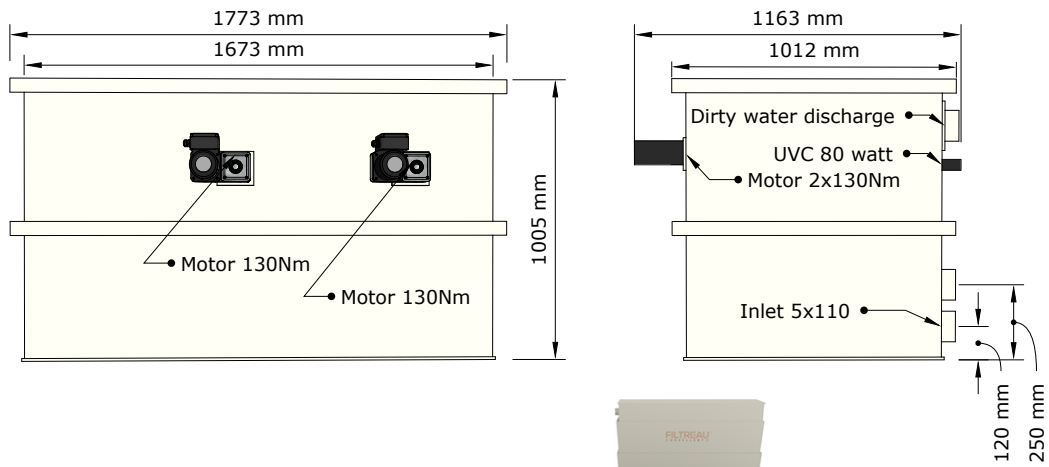

FILTREAU
EXCELLENT

WMC40ROT	COMBI DRUM 30/50 ROTATE TRICKLE
----------	------------------------------------



Download online

EXCELLENT LINE

Dimensions WMC41ROG Combi Drum 50/70 Rotate Gravity

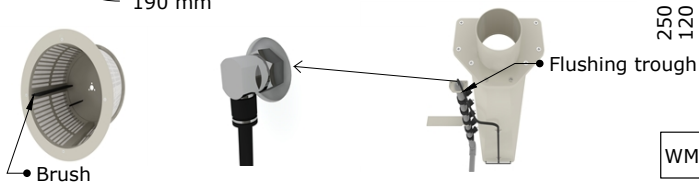
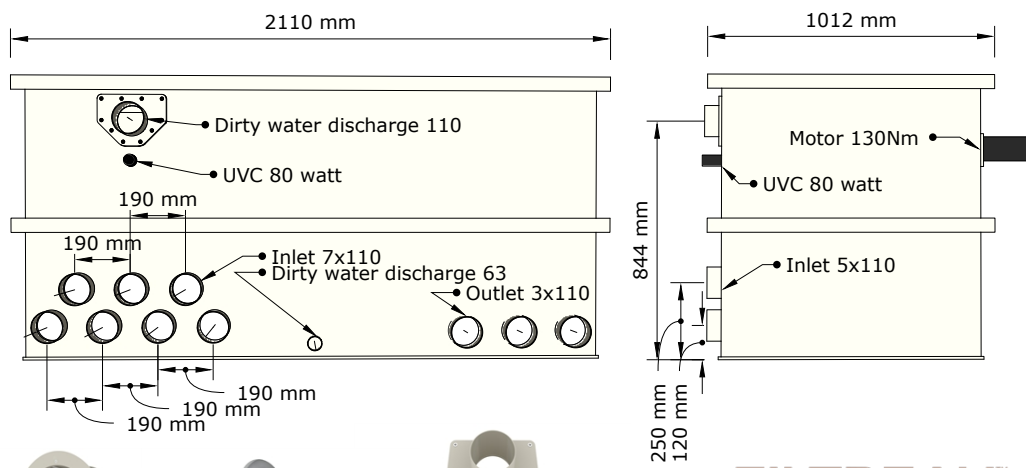
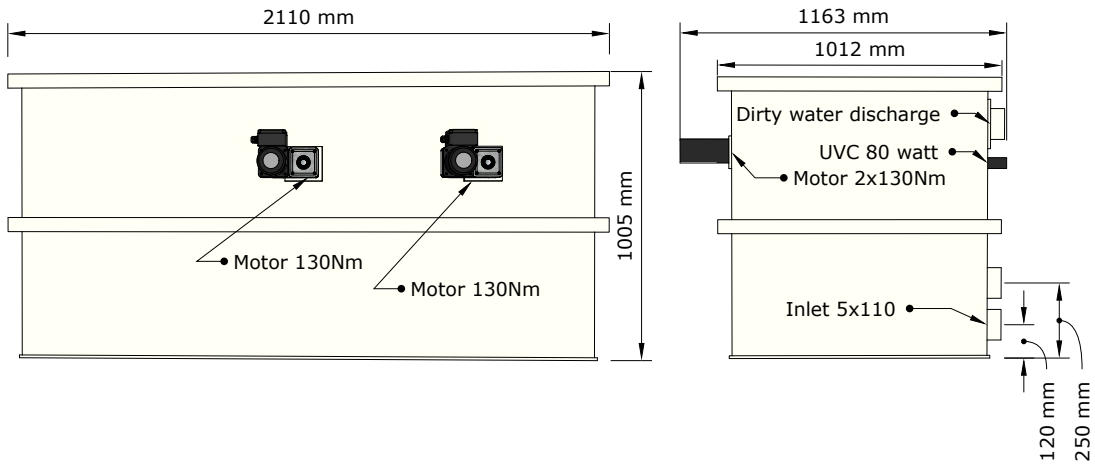

FILTREAU™
EXCELLENT

WMC41ROG	COMBI DRUM 50/70 ROTATE
----------	----------------------------



[Download online](#)

Dimensions WMC41ROP Combi Drum 50/70 Rotate Pump

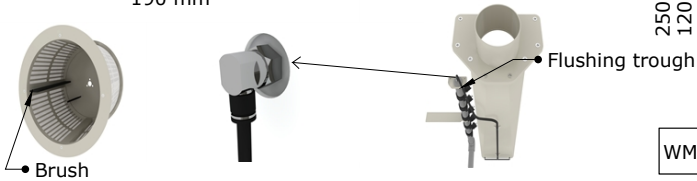
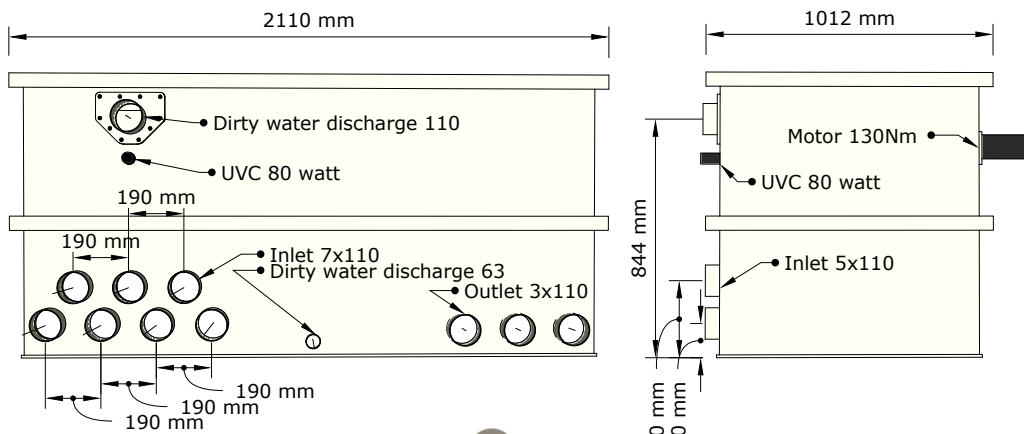
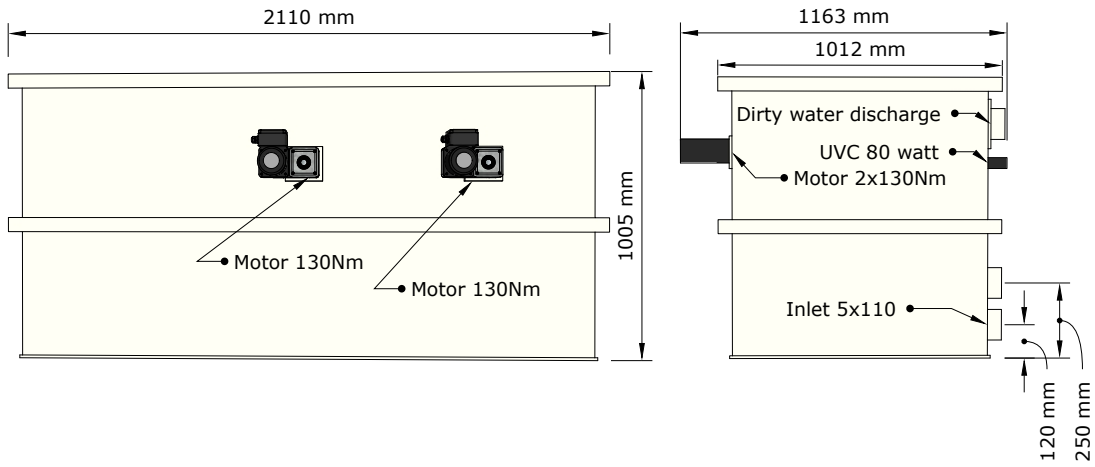

FILTREAU
EXCELLENT

WMC41ROG	COMBI DRUM 50/70 ROTATE
----------	-------------------------



Download online

EXCELLENT LINE

Dimensions WMC41ROT Combi Drum 50/70 Rotate Trickle

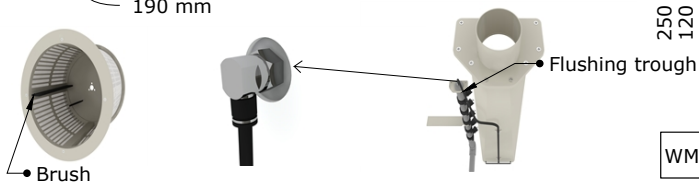
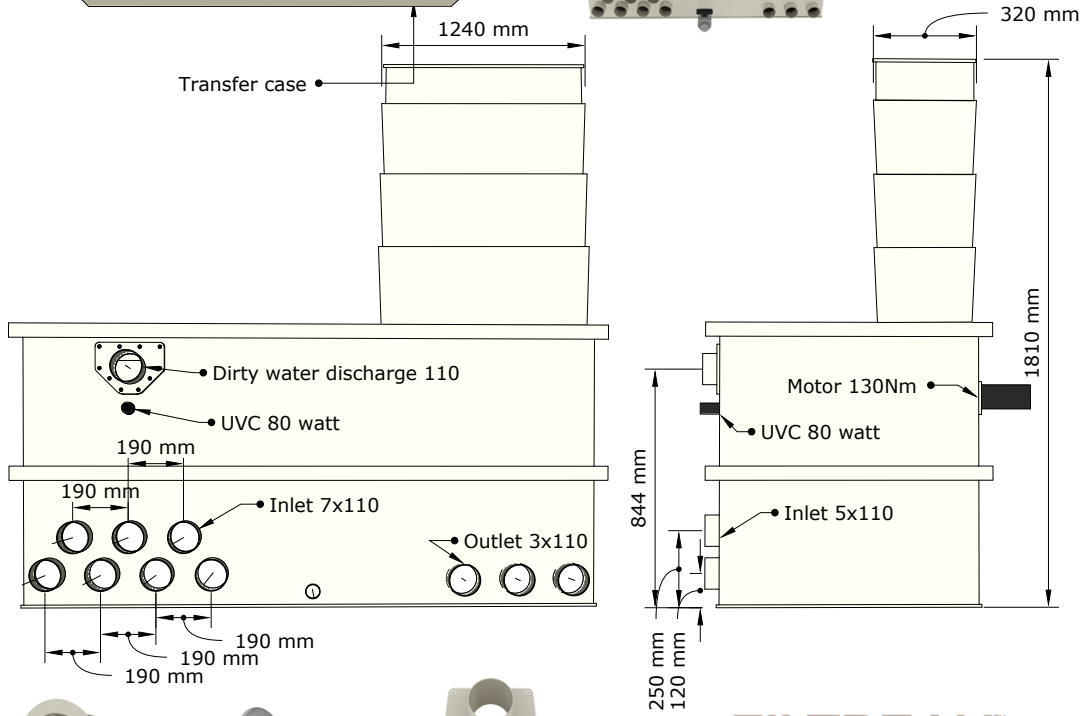
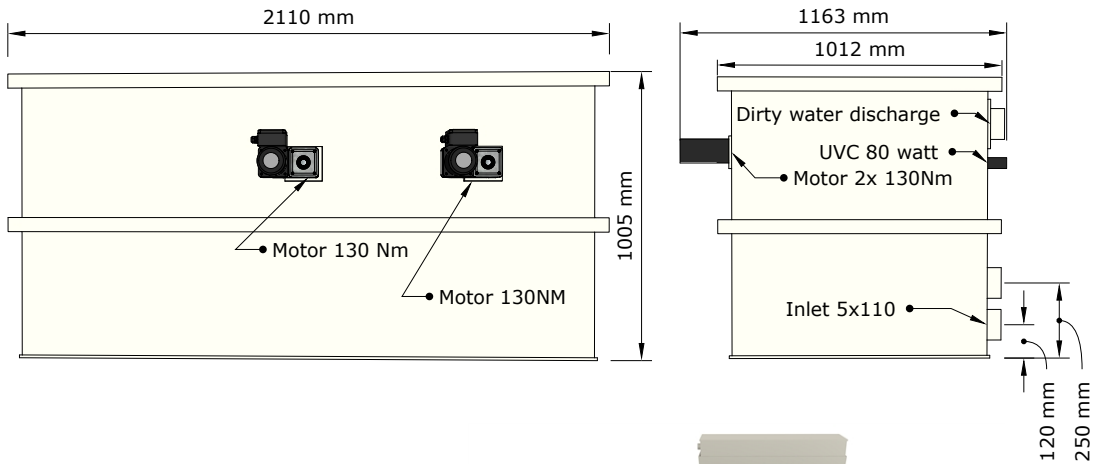

FILTREAU™
EXCELLENT

WMC41ROT	COMBI DRUM 50/70 ROTATE TRICKLE
----------	------------------------------------



[Download online](#)

Dimensions WMC43MTG combi drum 30/40 LOW Mountain Tree Gravity

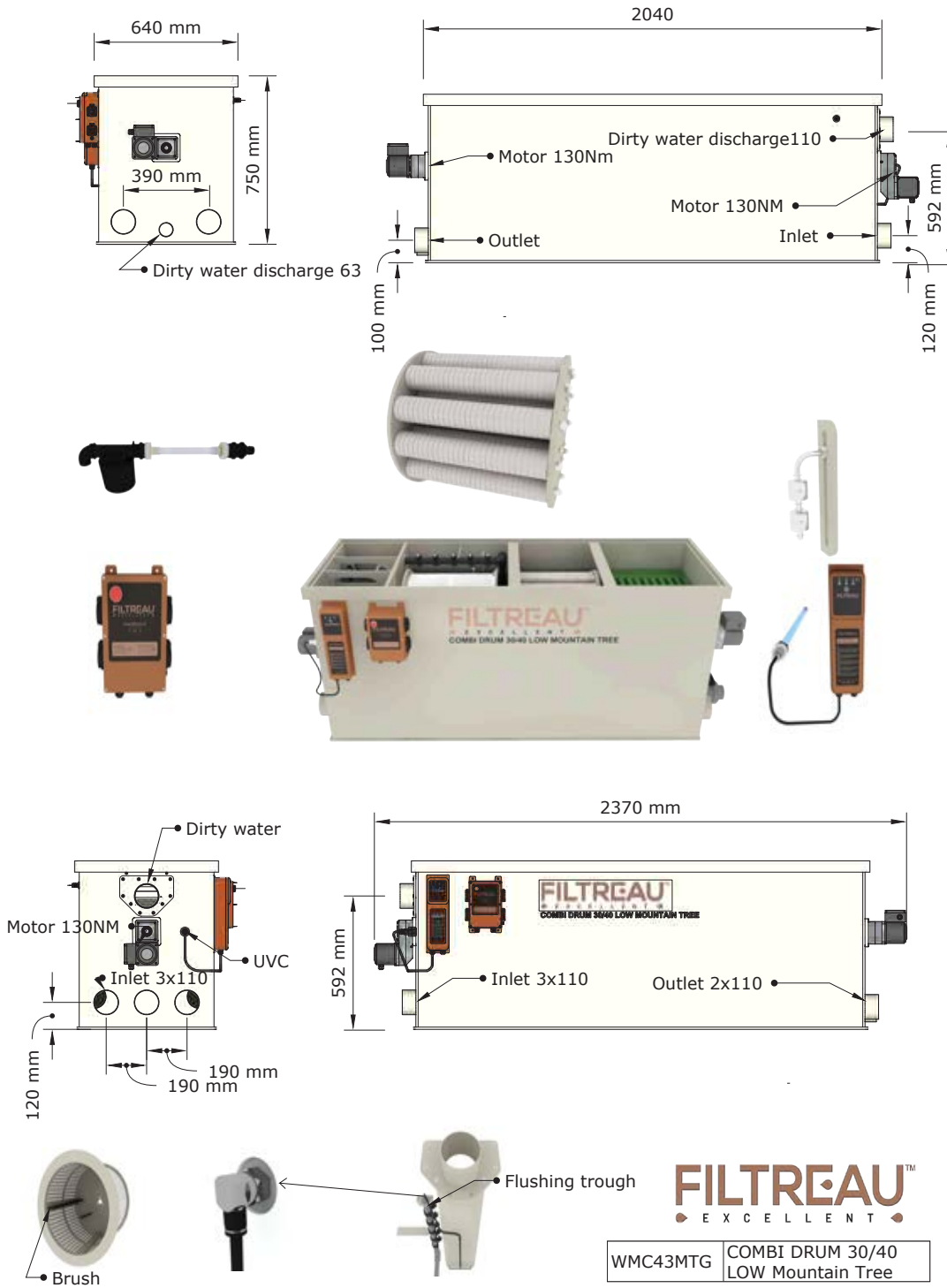

Download online

EXCELLENT LINE

Dimensions WMC44MTG combi drum 50/65 XL Mountain Tree Gravity

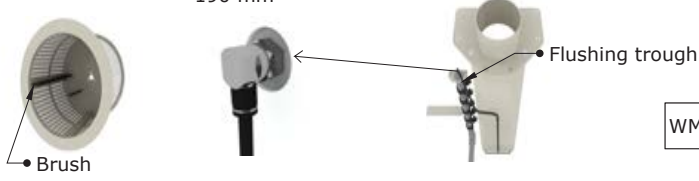
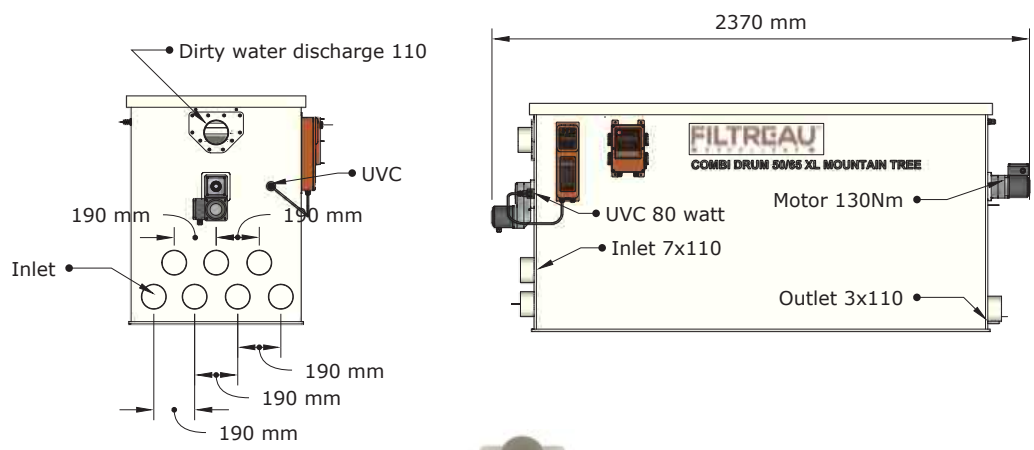
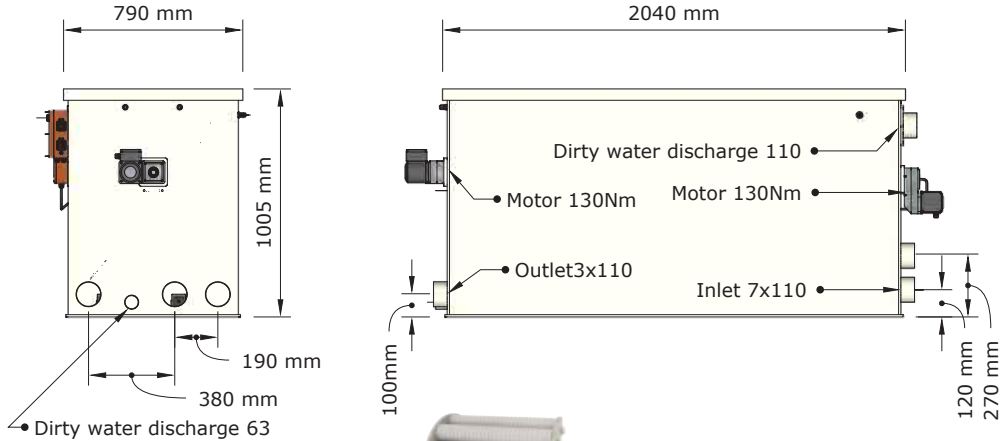

FILTREAU™
EXCELLENT

WMC44MTG COMBI DRUM 50/65 XL Mountain Tree



[Download online](#)

Dimensions WMC45MTG combi drum 30/50 LOW Mountain Tree Gravity

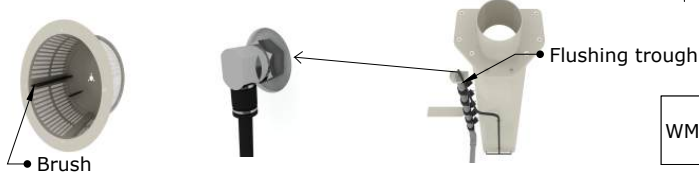
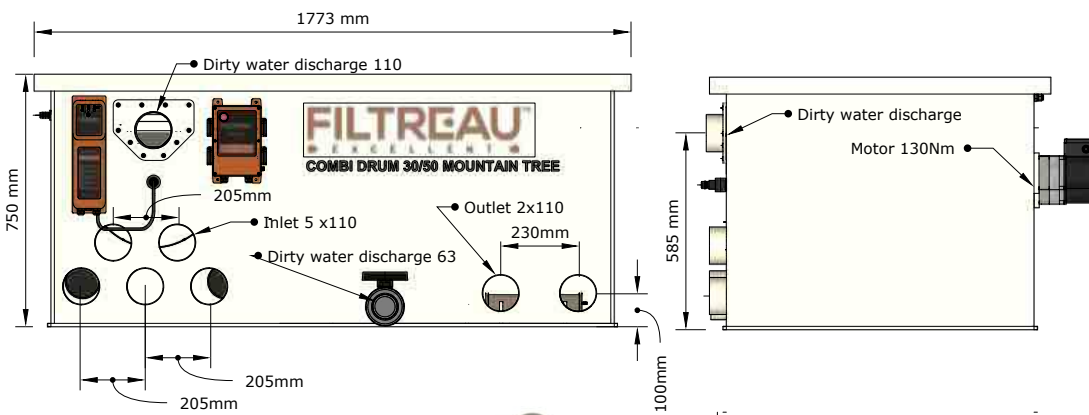
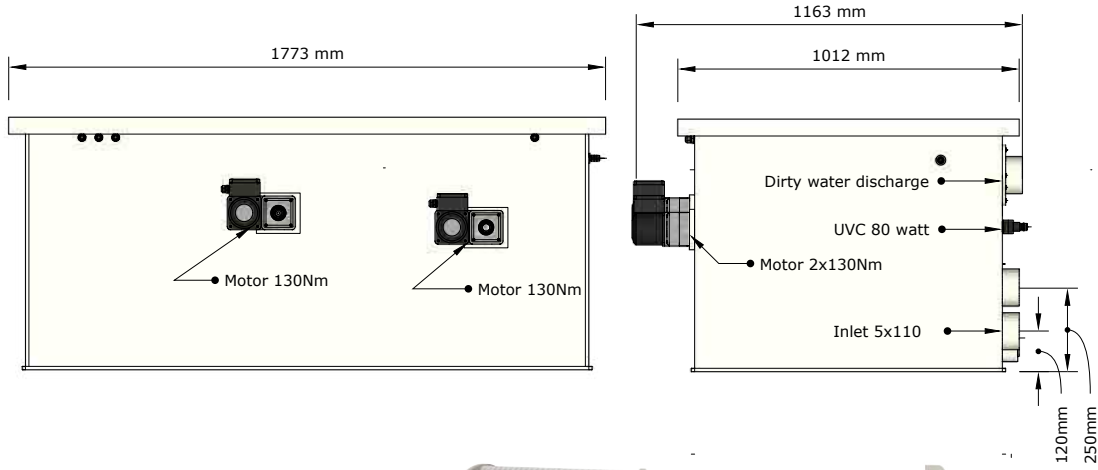

FILTREAU
EXCELLENT

WMC45MTG	COMBI DRUM 30/50 LOW MOUNTAIN TREE
----------	--



Download online

EXCELLENT LINE

Dimensions WMC46MTG combi drum 50/70 Mountain Tree Gravity

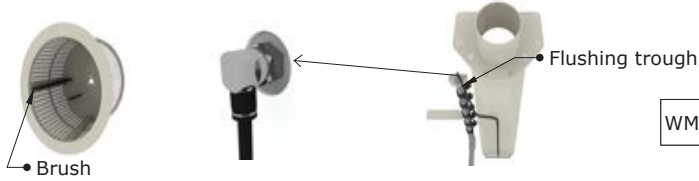
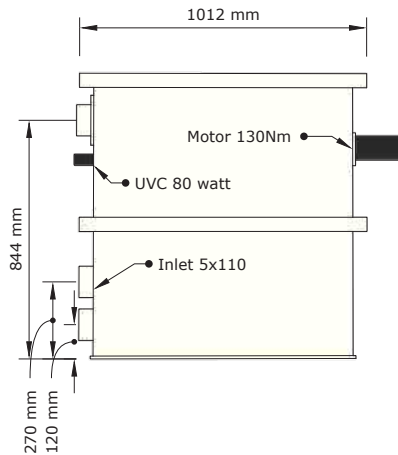
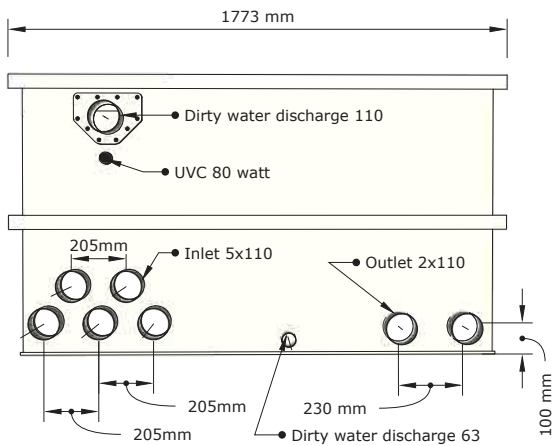
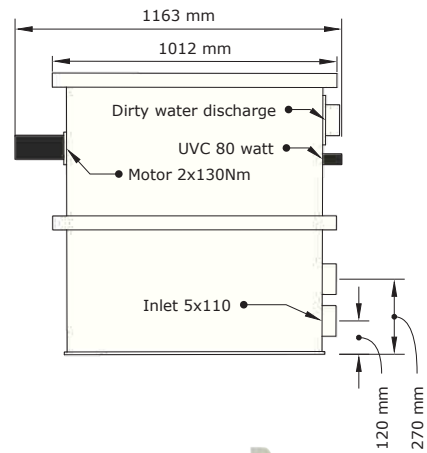
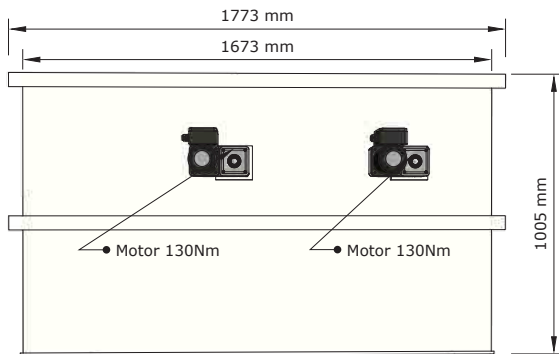

FILTREAU™
EXCELLENT

WMC46MTG COMBI DRUM 50/70 MOUNTAIN TREE



Download online

Dimensions WMC47MTG combi drum 80/100 XXL Mountain Tree Gravity

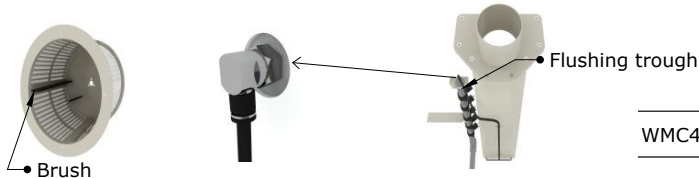
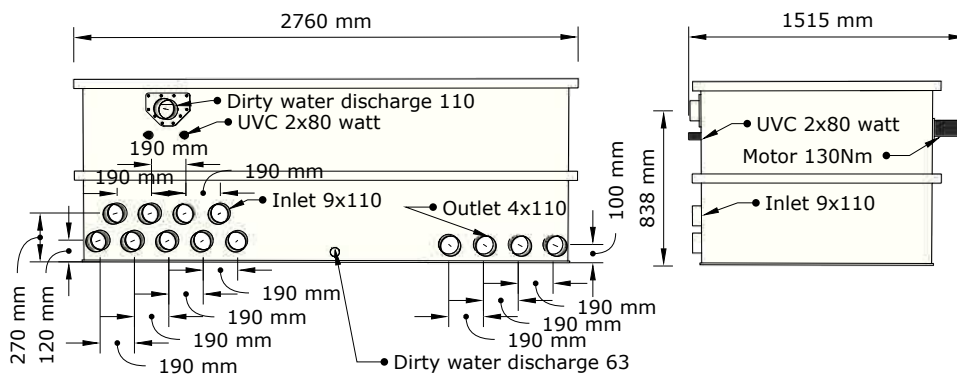
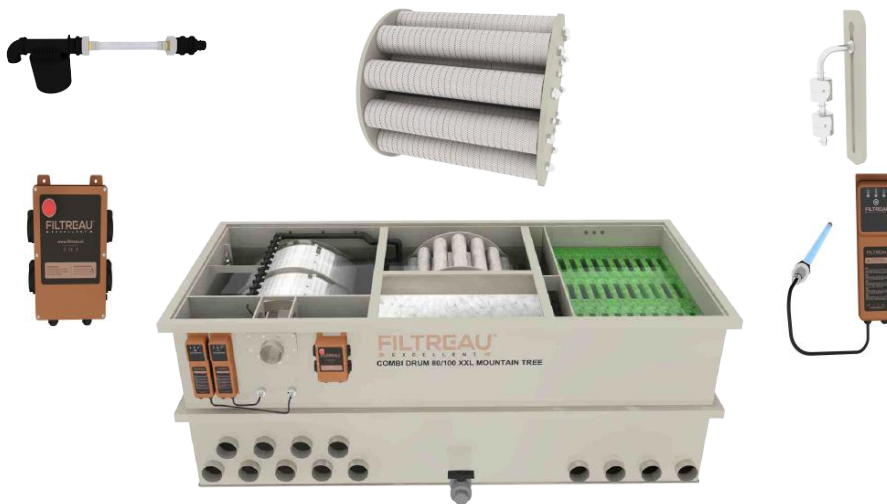
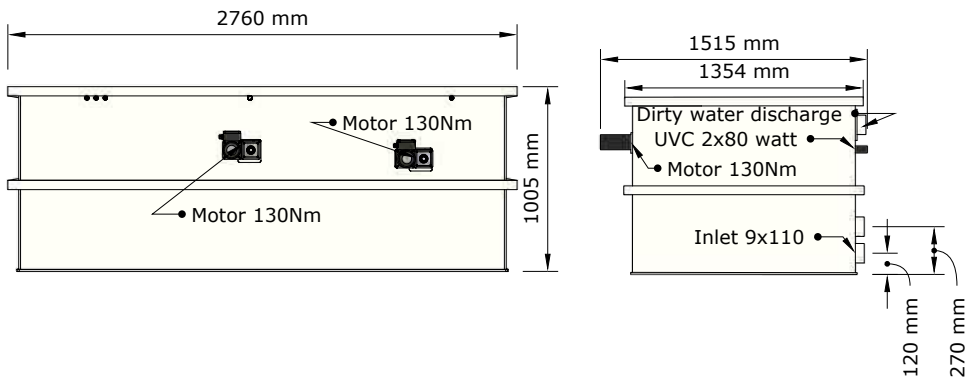

FILTREAU
EXCELLENT

WMC47MTG	COMBI DRUM 80/100 XXL Mountain Tree
----------	--



Download online



Dimensions

Basic line

Dimensions BB00001 moving-bed filter 190L PE

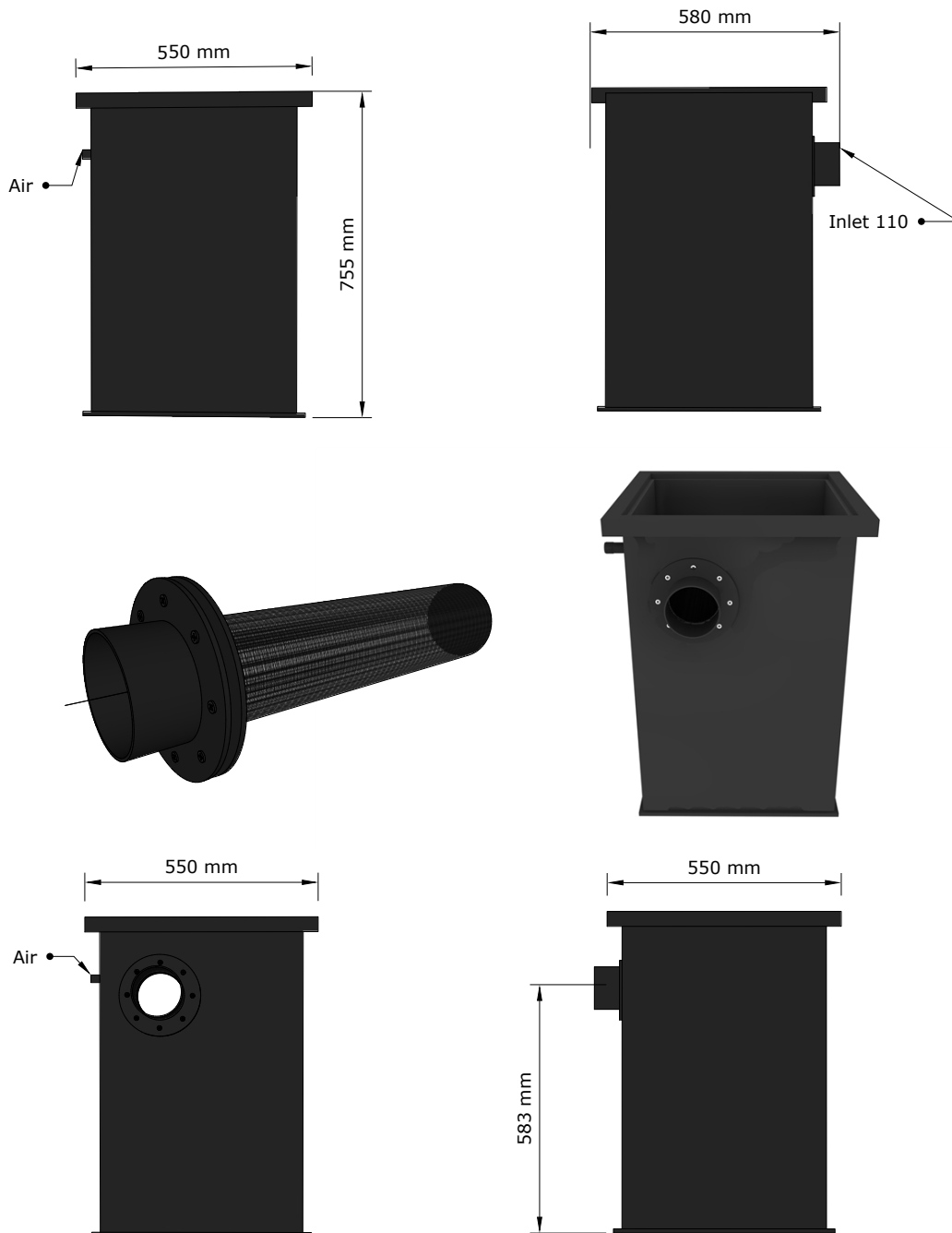

FILTREAU™

BWB filter



Download online

BASIC LINE

Dimensions Com0001 combi PF 20

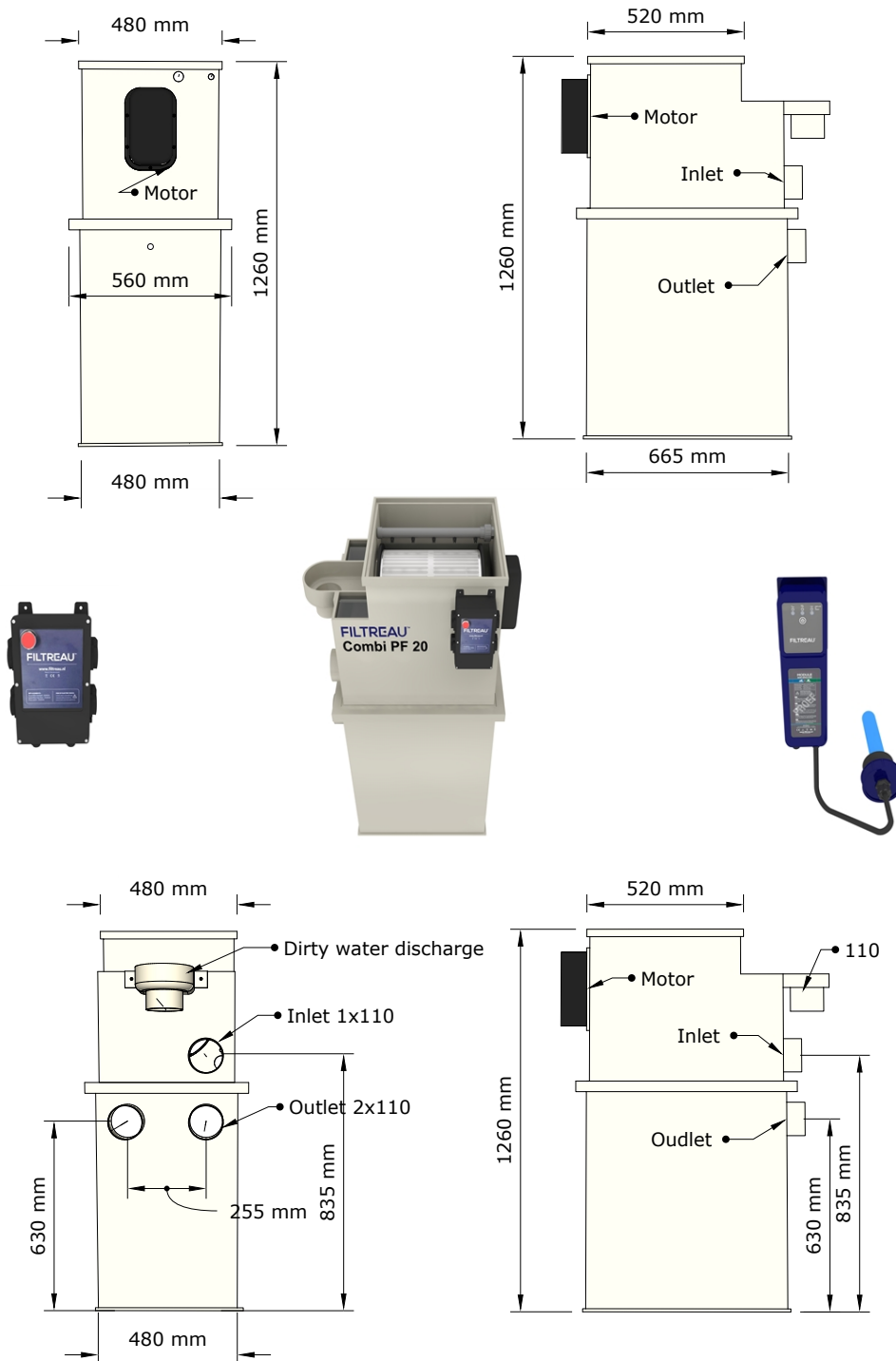

FILTREAU™

COM0001

COMBI PF20



[Download online](#)

Dimensions COM002 combi-NEXT incl. UVC (Gravity) PP

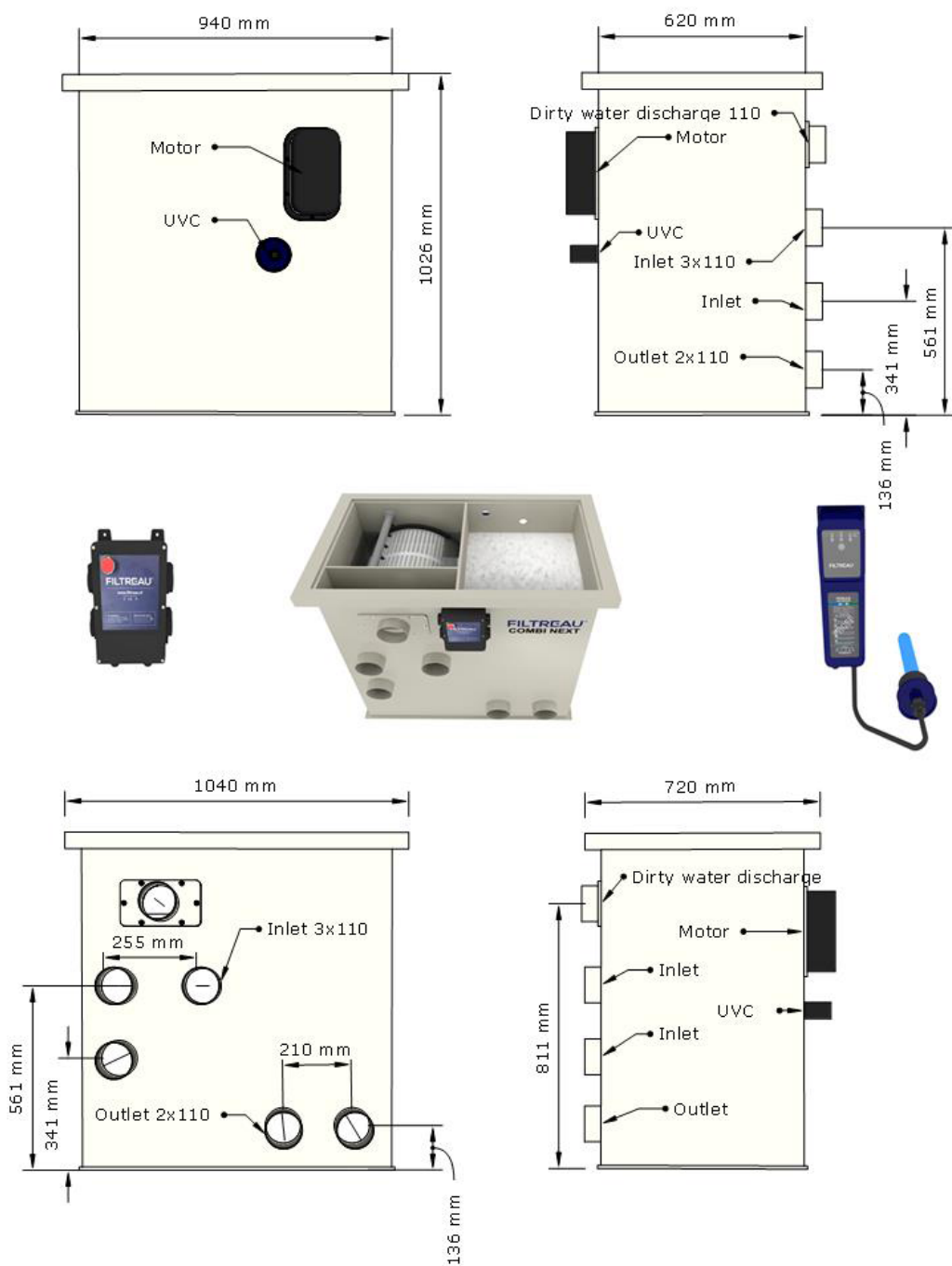

FILTREAU™

Com 0002

COMBI NEXT



Download online

BASIC LINE

Dimensions COM0003 combi-AFTER incl. UVC (Gravity)

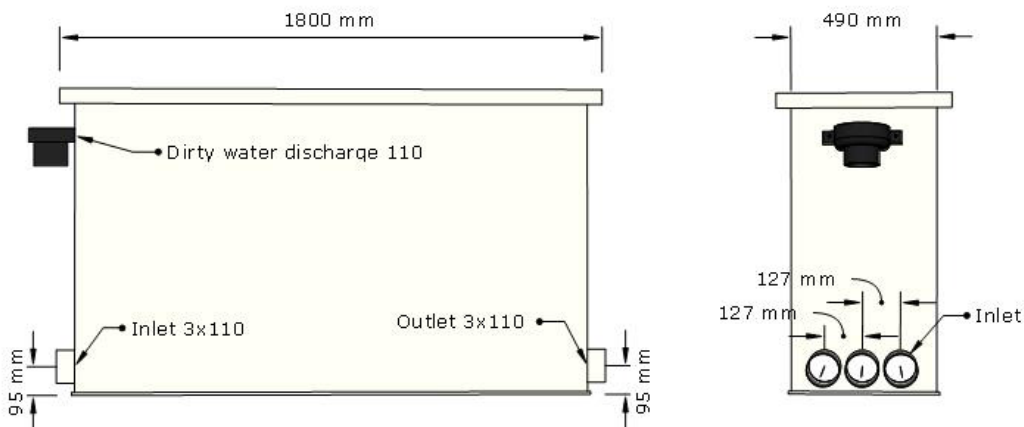
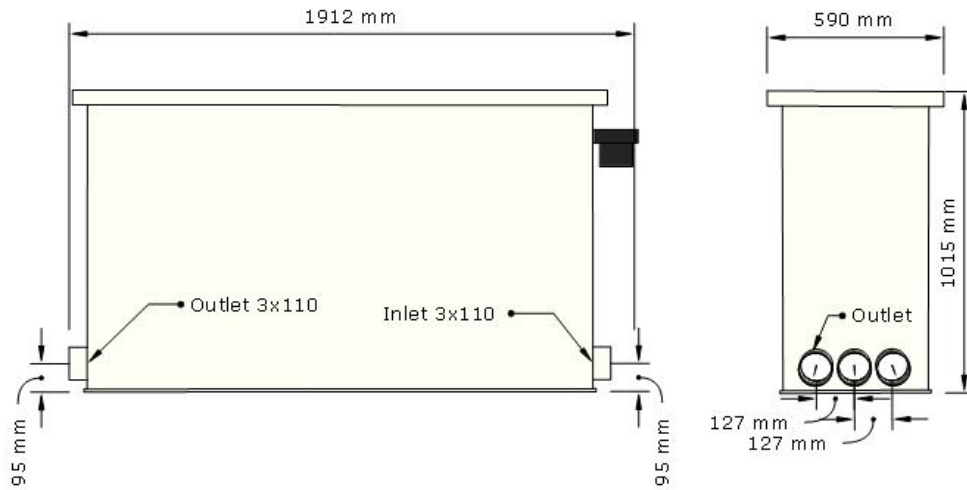

FILTREAU™

COM0003	AFTER
---------	-------



Download online

Dimensions COM0020 combi-2 gravity (moving-bed) incl. UVC

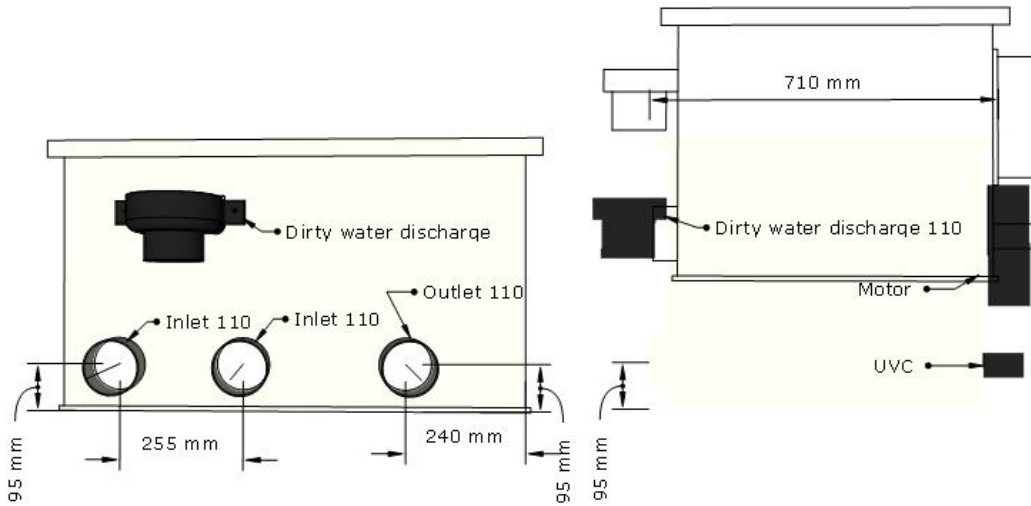
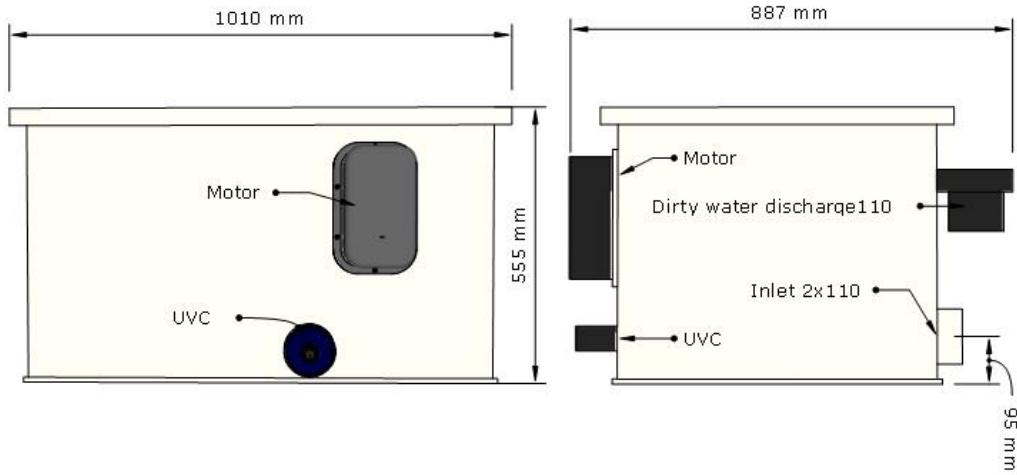

FILTREAU™

COM0020	COMBI 2
---------	---------



Download online

BASIC LINE

Dimensions COM0050IN Combi 50XL Gravity/ incl. rinsepump incl. 2x UV-C

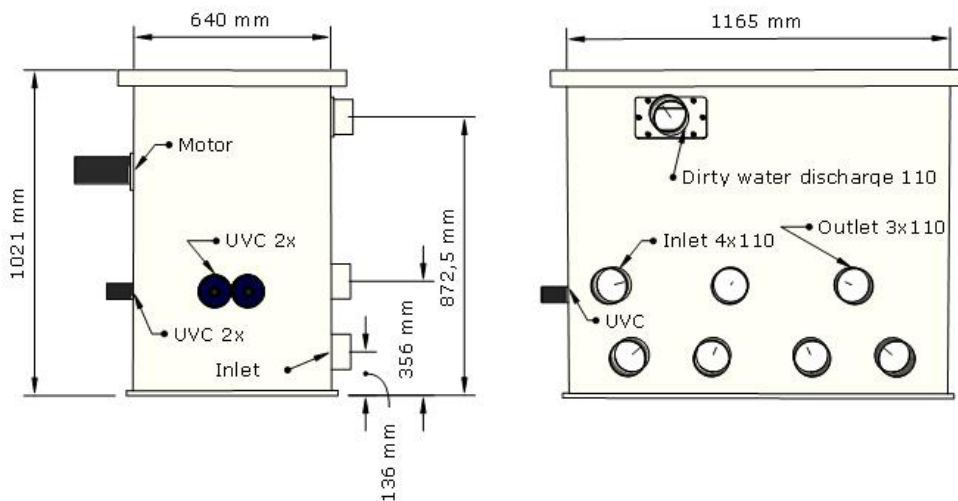
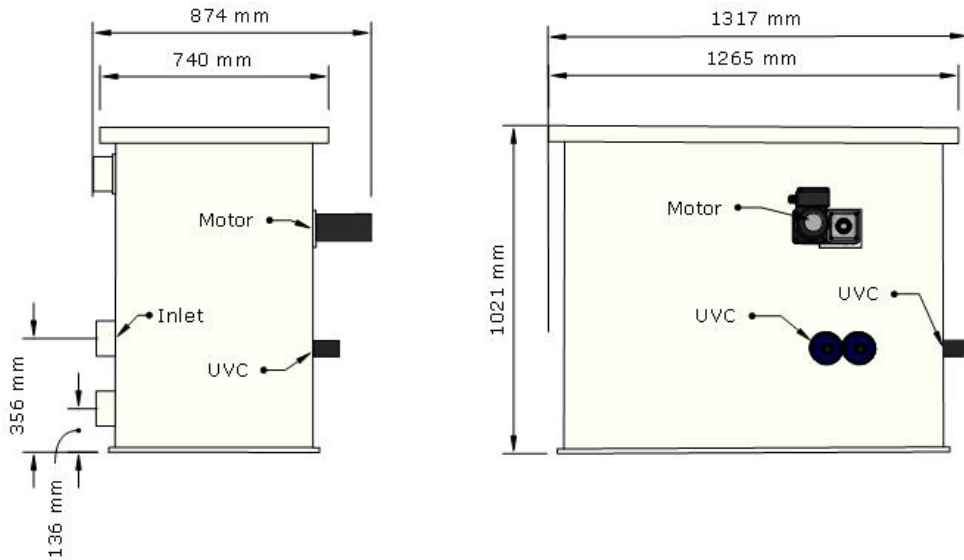

FILTREAU™

COM0050IN

COMBI 50 XL



[Download online](#)

Dimensions COM0050IN Combi 50XL Gravity/ incl. rinsepump incl. 2x UV-C

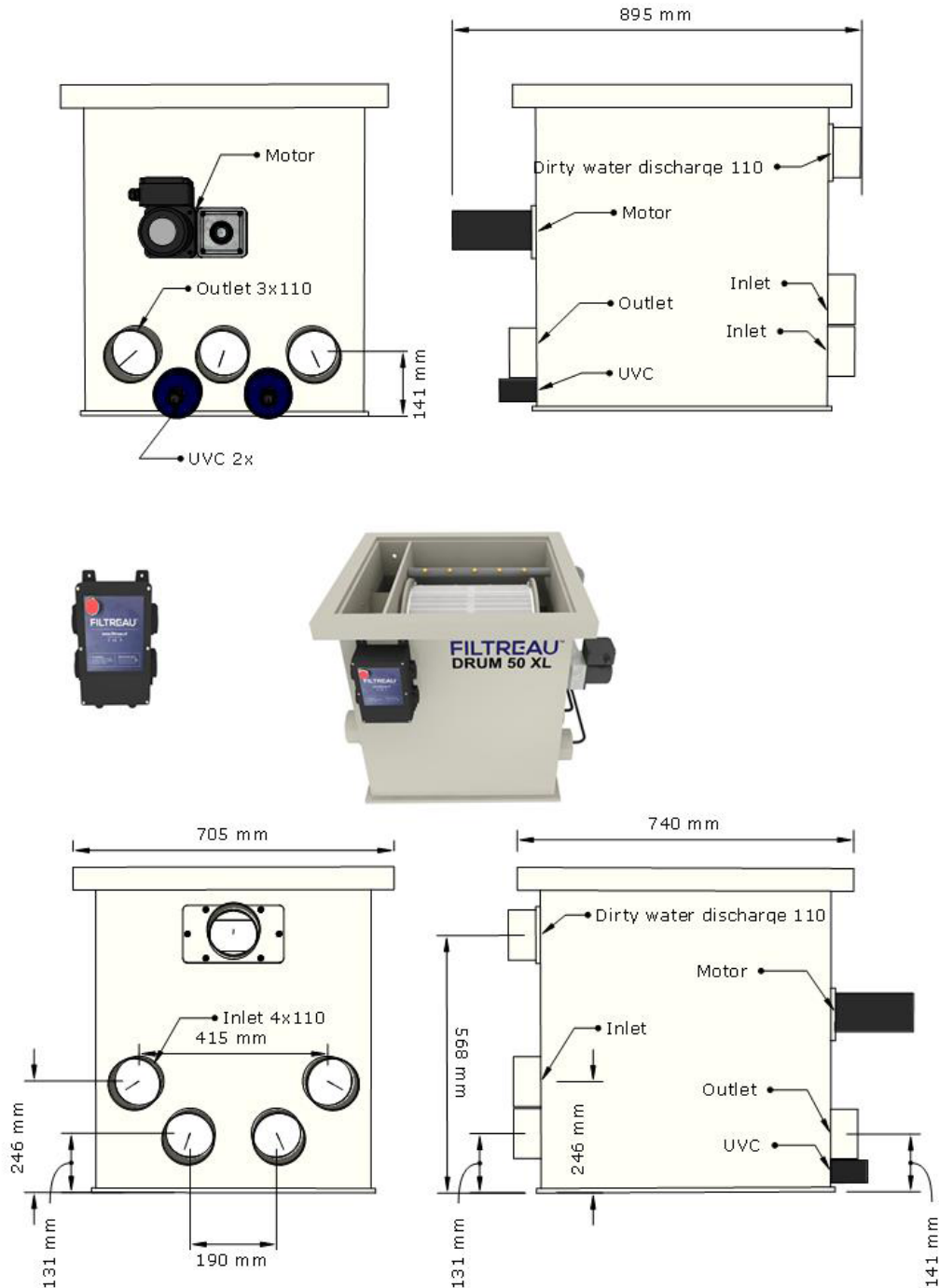

FILTREAU™

COM0050IN | DRUM 50 XL



Download online

BASIC LINE

Dimensions RO0001IN Rotate BioFilter Gravity incl. 2x UV-C 2x SPG XL

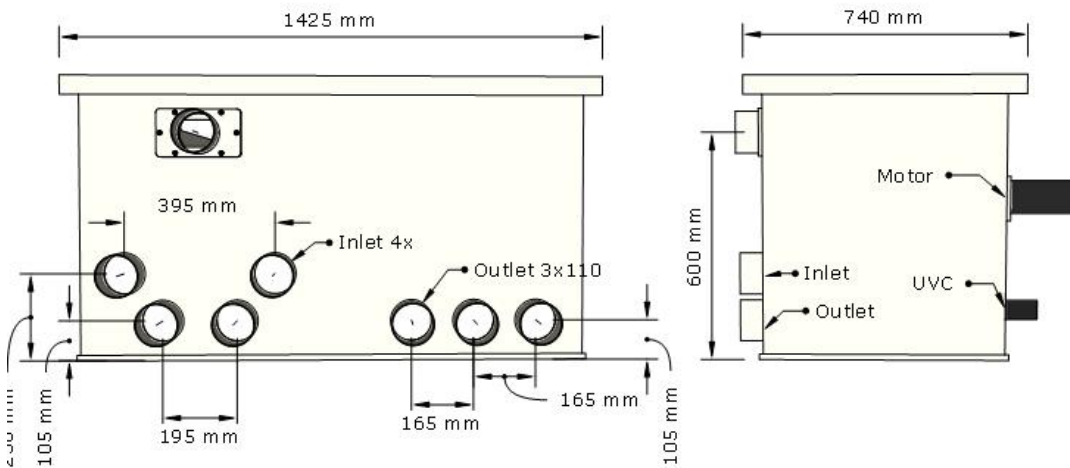
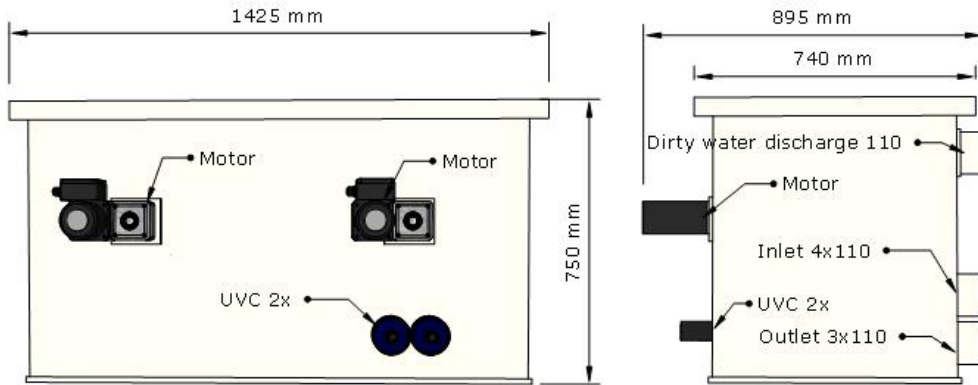

FILTREAU™

RO0001IN	ROTATE BIO
----------	------------



[Download online](#)

Dimensions TR00001 Drum-Filter incl. UVC Gravity

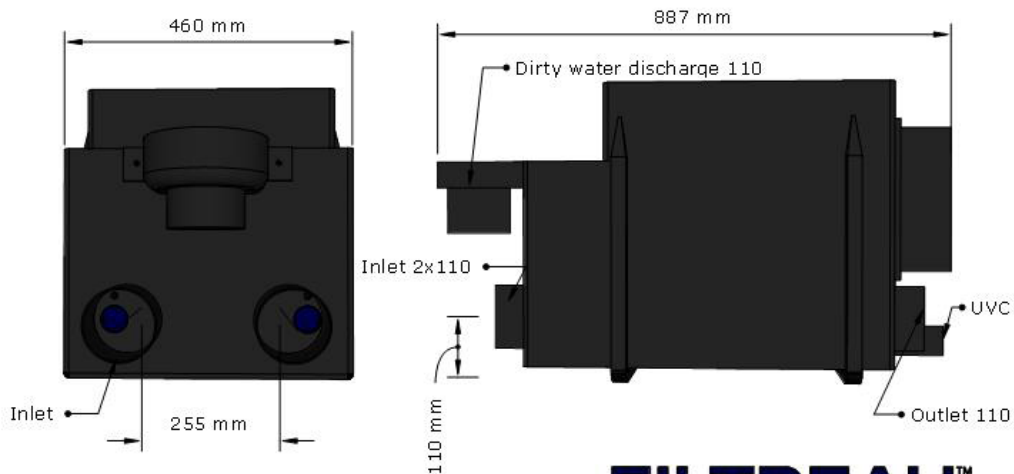
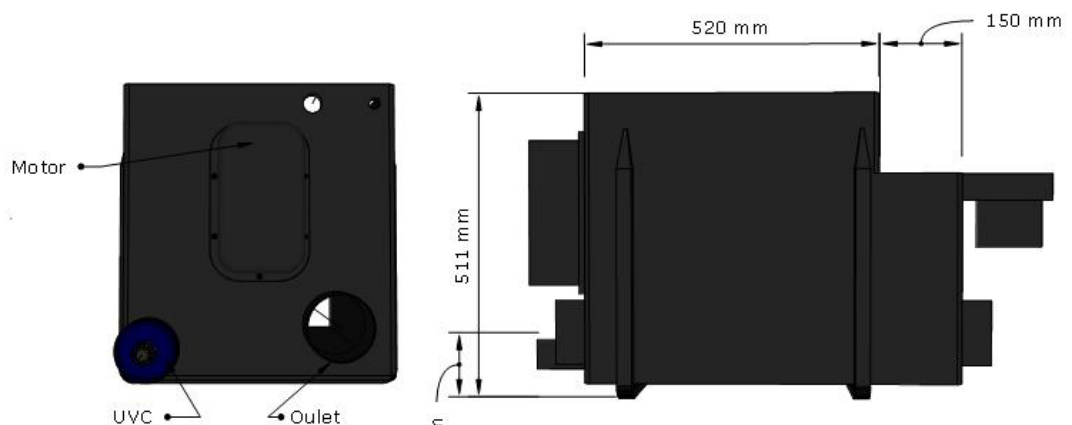

FILTREAU™

TR00001	Black drum
---------	------------



[Download online](#)

BASIC LINE

Dimensions TR00004 Drum-Filter HF30 (Gravity) PP

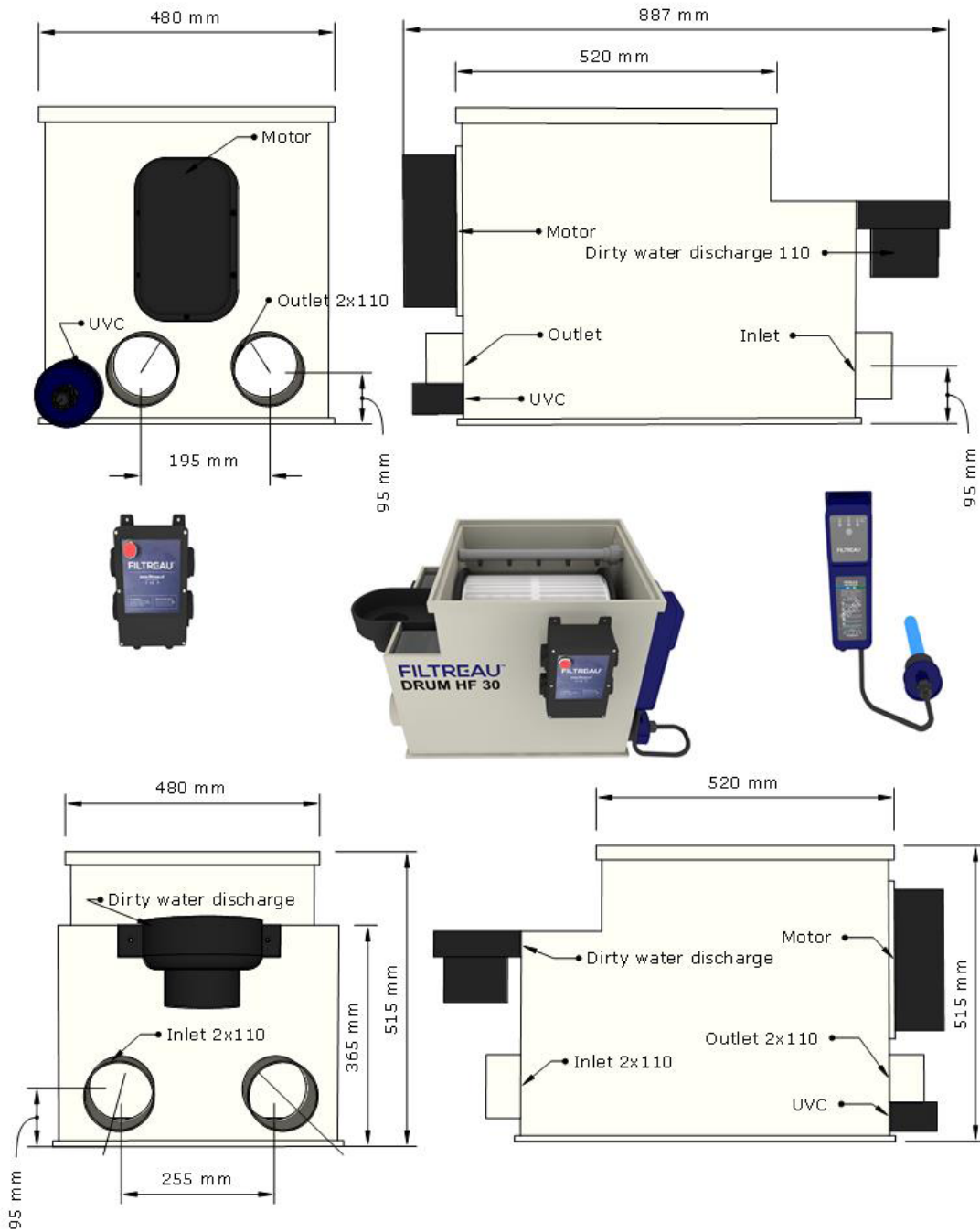

FILTREAU™

TR00004	DRUM HF 30
---------	------------



Download online

Why choose a FILTREAU filter?

- ✓ Sustainable Production
- ✓ Custom-made / Private Label
- ✓ Price-performance Ration
- ✓ Service-driven
- ✓ 100% produced in The Netherlands

40+ years experience

Low prices, high quality

Our years of experience mean that we know exactly what works and what doesn't. This puts us in an excellent position to market high quality water filtration products. We keep our prices low by developing and producing all products in-house.



Your own brand name

Private label

Bringing our products to market under your own brand name? That's possible at Wimäca.

Together we look at your wishes and we can fully shape our products in your own style.

From your own packaging and user manuals to various promotional materials for trade shows and even a website in your look and feel. Wimäca offers countless possibilities to bring your product to market under your own name.

+62 countries

Worldwide shipping

Wimäca International develops and produces all its (Filtreau) products in the Netherlands.

From our base in Son en Breugel, we serve the professional market worldwide.

We supply customers in over 62 countries.



UV-C

The ultimate disinfection method

UV-C

The function of a UV lamp in a pond or swimming pool

The primary function of a UV lamp in a pond or swimming pool is to control suspended algae, resulting in clear and clean water. Other terms for a UV lamp include UV clarifier and UV sterilizer.

Suitable for various applications



Highly effective in killing microorganisms

Fast and efficient disinfection



Do not require chemicals



✔ Sustainable production

✔ 40 years experience

✔ Private label / custom solutions

The operation is as follows:

A UV lamp is effective in keeping pond water clear by controlling suspended algae, but it also helps reduce excess nutrients and other causes of algae blooms. We therefore always recommend installing a UV-C lamp in combination with a filter, such as a drum filter, for your pond or swimming pool.

Control of suspended algae:

When pond or pool water containing suspended algae flows through a UV unit, it is exposed to ultraviolet light. This damages the DNA of the algae, causing them to die and clump together.

Clumping:

As a result of UV exposure, the dead algae aggregate into larger particles.

Filtration:

These larger particles can then be more easily removed by the pond or pool filter. As the water passes through the filter, the particles are screened out, leaving the water clear.

Reduction of pathogens:

In addition to controlling suspended algae, a UV lamp also helps reduce harmful pathogens and bacteria in the water. This promotes a healthy environment for flora and fauna in and around the pond.

How long should a UV lamp be on in a pond and/or swimming pool?

A UV lamp should operate 24 hours a day when pumps and filtration systems are used to maintain water quality (traditional pond and swimming pool systems). This is particularly important during spring and summer, when sunlight intensity is highest and algae growth is at its peak.

It is also possible to operate the lamp less frequently, for example during periods of increased sunlight or when algae levels rise. In such cases, the lamp can be switched on for 4–6 hours per day. This has a lower impact on both the environment and energy consumption, while still helping to control algae growth.

Please note that a UV lamp only addresses suspended algae and does not eliminate the underlying cause.



What is the lifespan of a UV lamp and how should it be replaced in time?

A UV lamp has an average effective lifespan of 12,000 hours. An ozone lamp has an average lifespan of 8,000 hours. After these hours have elapsed, the lamp may still operate, but its disinfection performance decreases significantly. It is therefore essential to replace the lamp in time.

Our recommendation is to replace the UV-C lamp once a year, as 12,000 hours is approximately equivalent to one year of operation.

It is also advisable to replace the lamp annually around the same period, preferably in spring. This ensures that pond or swimming pool owners benefit from clean, clear and healthy water throughout the entire summer season.

Some Filtreau UV-C products are equipped with a built-in timer to accurately track operating hours. This allows you to see exactly when the lamp needs to be replaced. The display indicates when replacement is required. Always replace the lamp at the same time each year.

How many watts should a UV lamp for a pond be?

The wattage determines the effectiveness of a UV lamp in a pond. As a guideline, use 2 to 4 watts per 1,000 liters of water for clear pond conditions, depending on fish load and other factors.

For ponds with a low to moderate fish stock, 2 watts per 1,000 liters may be sufficient.

We recommend replacing the UV-C lamp annually. Although the lamp may still be operating after a season, UV output decreases over time, reducing its effectiveness.

For more information about private label opportunities, please contact our sales department. Our team will be happy to assist you.

UV-C COMPACT

The function of a UV lamp in a pond or swimming pool

The primary function of a UV lamp in a pond or swimming pool is to control suspended algae, resulting in clear and clean water. Other terms for a UV lamp include UV clarifier and UV sterilizer.

Suitable for various applications 



 Highly effective in killing microorganisms

Fast and efficient disinfection 

 Do not require chemicals

 Sustainable production

 40 years experience

 Private label / custom solutions

The operation is as follows:

UV lamp is effective in keeping pond water clear by controlling suspended algae, but it also helps reduce excess nutrients and other causes of algae blooms. We therefore always recommend installing a UV-C lamp in combination with a filter, such as a drum filter, for your pond.

Control of suspended algae:

When pond water containing suspended algae flows through a UV unit, it is exposed to ultraviolet light. This damages the DNA of the algae, causing them to die and clump together.

Clumping:

As a result of UV exposure, the dead algae aggregate into larger particles.

Filtration:

These larger particles can then be more easily removed by the pond filter. As the water passes through the filter, the particles are screened out, leaving the water clear.

Reduction of pathogens:

In addition to controlling suspended algae, a UV lamp also helps reduce harmful pathogens and bacteria in the water. This promotes a healthy environment for flora and fauna in and around the pond.

UV-C LINE COMPACT

The Filtreau UV-C Compact ensures crystal-clear water. With its advanced design and high-quality materials, the unit generates a high level of UV-C radiation with a wavelength of exactly 253.7 nm. This high radiation level eliminates virtually all bacteria, viruses and even fungi, resulting in clean, clear water.

Technical specifications



Product	Filtreau UV-C Compact 16W	Filtreau UV-C Compact 40W	Filtreau UV-C Compact 75W
Suitable for ponds	Yes	Yes	Yes
Suitable for swimming pools	No	No	No
Watt	16W	40W	75W
Flow rate for 30 mJ/cm ²	12 m ³ /h	18 m ³ /h	22 m ³ /h
Max. pressure	3.0 bar	3.0 bar	3.0 bar
Diameter	70 mm	70 mm	70 mm
Length × width	430 mm	740 mm	740 mm
Cable length	1,2 m	1,2 m	1,2 m
Diameter in outlet	63/50/40/32/25 mm	63/50/40/32/25 mm	63/50/40/32/25 mm
Housing	Aluminium	Aluminium	Aluminium
Electrical load	230V AC 50/60 Hz	230V AC 50/60 Hz	230V AC 50/60 Hz
Max. current	0,425 A	0,425 A	0,425 A
Lamp power	16W	40W	75W
Lamp lifespan	9.000 h	9.000 h	9.000 h
Indicator	-	-	-
Spare parts			
Replacement lamp	RLCOM01	RLCOM02	RLCOM03
Quartz glass	QS0001	QS0007	QS0007
Electrical unit	EPCOM01	EPCOM02	EPCOM03
Housing	HOU0015	HOU0016	HOU0016
Item no.	UVCOM01	UVCOM02	UVCOM03



Discover the complete UV-C series

UV-C COMPACT PLUS INOX 304

The function of a UV lamp in a pond

The primary function of a UV lamp in a pond is to control suspended algae, resulting in clear and clean water. Other terms for a UV lamp include UV clarifier and UV sterilizer.

Suitable for various applications +

+ Highly effective in killing microorganisms



Fast and efficient disinfection +

+ Do not require chemicals

✔ Sustainable production

✔ 40 years experience

✔ Private label / custom solutions

The operation is as follows:

UV lamp is effective in keeping pond water clear by controlling suspended algae, but it also helps reduce excess nutrients and other causes of algae blooms. We therefore always recommend installing a UV-C lamp in combination with a filter, such as a drum filter, for your pond.

Control of suspended algae:

When pond water containing suspended algae flows through a UV unit, it is exposed to ultraviolet light. This damages the DNA of the algae, causing them to die and clump together.

Clumping:

As a result of UV exposure, the dead algae aggregate into larger particles.

Filtration:

These larger particles can then be more easily removed by the pond filter. As the water passes through the filter, the particles are screened out, leaving the water clear.

Reduction of pathogens:

In addition to controlling suspended algae, a UV lamp also helps reduce harmful pathogens and bacteria in the water. This promotes a healthy environment for flora and fauna in and around the pond.

UV-C LINE COMPACT PLUS INOX 304

The Filtreau UV-C Compact Plus Inox ensures crystal-clear water. With its advanced design and high-quality materials, the unit generates a high level of UV-C radiation with a wavelength of exactly 253.7 nm. This high radiation level eliminates virtually all bacteria, viruses and even fungi, resulting in clean, clear water.

Technical specifications

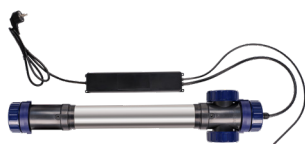

Product	Filtreau UV-C Compact Plus Inox 40W	Filtreau UV-C Compact Plus Inox 75W
Suitable for ponds	Yes	Yes
Suitable for swimming pools	No	No
Watt	40W	75W
Flow rate for 30 mJ/cm ²	18 m ³ /h	22 m ³ /h
Max. pressure	3.0 bar	3.0 bar
Diameter	70 mm	70 mm
Length × width	740 mm	740 mm
Cable length	1,2 m	1,2 m
Diameter in outlet	63/50/40/32/25 mm	63/50/40/32/25 mm
Housing	INOX 304	INOX 304
Electrical load	230V AC 50/60 Hz	230V AC 50/60 Hz
Max. current	0,425 A	0,425 A
Lamp power	40W	75W
Lamp lifespan	8.000 h	8.000 h
Indicator	-	-
Spare parts		
Replacement lamp	RLCOM02	RLCOM03
Quartz glass	QS0007	QS0007
Electrical unit	EPCOM02	EPCOM03
Housing	HOU0024	HOU0024
Item no.	UVCOM04	UVCOM05



**Discover the
complete UV-C
series**

UV-C Copper Ionizer

The function of a UV lamp in a pond or swimming pool

The primary function of a UV lamp in a pond or swimming pool is to control suspended algae, resulting in clear and clean water. Other terms for a UV lamp include UV clarifier and UV sterilizer.

Suitable for various applications



Highly effective in killing microorganisms



Do not require chemicals

Fast and efficient disinfection



Stainless steel

✔ Sustainable production

✔ 40 years experience

✔ Private label / custom solutions

The operation is as follows:

UV lamp is effective in keeping pond water clear by controlling suspended algae, but it also helps reduce excess nutrients and other causes of algae blooms. We therefore always recommend installing a UV-C lamp in combination with a filter, such as a drum filter, for your pond.

Control of suspended algae:

When pond water containing suspended algae flows through a UV unit, it is exposed to ultraviolet light. This damages the DNA of the algae, causing them to die and clump together.

Clumping:

As a result of UV exposure, the dead algae aggregate into larger particles.

Filtration:

These larger particles can then be more easily removed by the pond filter. As the water passes through the filter, the particles are screened out, leaving the water clear.

Reduction of pathogens:

In addition to controlling suspended algae, a UV lamp also helps reduce harmful pathogens and bacteria in the water. This promotes a healthy environment for flora and fauna in and around the pond.

UV-C LINE Copper Ionizer

The Filtreau UV-C Copper Ionizer purifies your water through copper electrolysis in combination with UV-C radiation. The Filtreau UV-C Copper Ionizer is installed after the pool filter, within the pipe system.

Technical specifications



Product	Filtreau UV-C Copper Ionizer 40W	Filtreau UV-C Copper Ionizer 80W
Suitable for ponds	Yes	Yes
Suitable for swimming pools	Yes	Yes
Watt	40W	80W
Flow rate for 30 mJ/cm ²	40m ³	80m ³
Max. pressure	3 bar	3 bar
Diameter	90 Ø	90 Ø
Length x width	970 mm	970 mm
Cable length	1,2 m	1,2 m
Diameter in outlet	63/50/40/32/25	63/50/40/32/25
Housing	INOX 316	INOX 316
Electrical load	230V AC 50/60 Hz	230V AC 50/60 Hz
Max. current	0,425A	0,8A
Lamp power	40W	80W
Lamp lifespan	-	-
Indicator	Yes	Yes
Spare parts		
Replacement lamp	RLCI001	RLCI002
Quartz glass	QS0003	QS0003
Electrical unit	EPCI0001	EPCI0002
Housing	HOU10001	HOU10001
Item no.	UVCI001	UVCI002



Discover the complete UV-C series

UV-C INOX Module Amalgam

The function of a UV lamp in a pond or swimming pool

The primary function of a UV lamp in a pond or swimming pool is to control suspended algae, resulting in clear and clean water. Other terms for a UV lamp include UV clarifier and UV sterilizer.

Suitable for various applications



Highly effective in killing microorganisms

Fast and efficient disinfection



Do not require chemicals

Stainless steel



✔ Sustainable production

✔ 40 years experience

✔ Private label / custom solutions

The operation is as follows:

UV lamp is effective in keeping pond water clear by controlling suspended algae, but it also helps reduce excess nutrients and other causes of algae blooms. We therefore always recommend installing a UV-C lamp in combination with a filter, such as a drum filter, for your pond.

Control of suspended algae:

When pond water containing suspended algae flows through a UV unit, it is exposed to ultraviolet light. This damages the DNA of the algae, causing them to die and clump together.

Clumping:

As a result of UV exposure, the dead algae aggregate into larger particles.

Filtration:

These larger particles can then be more easily removed by the pond filter. As the water passes through the filter, the particles are screened out, leaving the water clear.

Reduction of pathogens:

In addition to controlling suspended algae, a UV lamp also helps reduce harmful pathogens and bacteria in the water. This promotes a healthy environment for flora and fauna in and around the pond.

UV-C LINE INOX Module Amalgam

The Filtreau UV-C Inox Module ensures crystal-clear water. Its sophisticated design and high-quality materials result in a high level of UV-C radiation with a precise wavelength of 253.7 nm. This high irradiation dose eliminates virtually all bacteria, viruses and even fungi, resulting in clean and clear water. As a result, the use of added chemicals (such as chlorine) can be reduced by up to 80%, creating a more natural and healthier water environment.

Technical specifications



Product	Filtreau UV-C INOX Module Amalgam 40W	Filtreau UV-C INOX Module Amalgam 80W
Suitable for ponds	Yes	Yes
Suitable for swimming pools	No	No
Watt	40W	80W
Flow rate for 30 mJ/cm ²	18 m ³ /h	22 m ³ /h
Max. pressure	3 bar	3 bar
Diameter	-	-
Length × width	360 mm	660 mm
Cable length	1,2 m	1,2 m
Diameter in outlet	-	-
Housing	-	-
Electrical load	230V AC 50/60 Hz	230V AC 50/60 Hz
Max. current	0,8 A	1,2 A
Lamp power	40W Amalgam	80W Amalgam
Lamp lifespan	12.000 h	12.000 h
Indicator	-	-
Spare parts		
Replacement lamp	RLM0001	RLM0002
Quartz glass	QS0005	QS0006
Electrical unit	EPM0001 SS	EPM0003 SS
Housing	-	-
Item no.	UVM0001SS	UVM0003SS



Discover the complete UV-C series

UV-C INOX Module High Output

The function of a UV lamp in a pond or swimming pool

The primary function of a UV lamp in a pond or swimming pool is to control suspended algae, resulting in clear and clean water. Other terms for a UV lamp include UV clarifier and UV sterilizer.

Suitable for various applications



Highly effective in killing microorganisms

Fast and efficient disinfection



Do not require chemicals

Stainless steel



✔ Sustainable production

✔ 40 years experience

✔ Private label / custom solutions

The operation is as follows:

UV lamp is effective in keeping pond water clear by controlling suspended algae, but it also helps reduce excess nutrients and other causes of algae blooms. We therefore always recommend installing a UV-C lamp in combination with a filter, such as a drum filter, for your pond.

Control of suspended algae:

When pond water containing suspended algae flows through a UV unit, it is exposed to ultraviolet light. This damages the DNA of the algae, causing them to die and clump together.

Clumping:

As a result of UV exposure, the dead algae aggregate into larger particles.

Filtration:

These larger particles can then be more easily removed by the pond filter. As the water passes through the filter, the particles are screened out, leaving the water clear.

Reduction of pathogens:

In addition to controlling suspended algae, a UV lamp also helps reduce harmful pathogens and bacteria in the water. This promotes a healthy environment for flora and fauna in and around the pond.

UV-C LINE INOX Module High Output

The Filtreau UV-C Inox Module ensures crystal-clear water. Its advanced design and high-quality materials generate a high level of UV-C radiation at a precise wavelength of 253.7 nm. This high irradiation dose eliminates virtually all bacteria, viruses and even fungi, resulting in clean and clear water. As a result, the use of added chemicals (such as chlorine) can be reduced by up to 80%, creating a more natural and healthier water environment.

Technical specifications



Product	Filtreau UV-C INOX Module High Output 40W	Filtreau UV-C INOX Module High Output 80W
Suitable for ponds	Yes	Yes
Suitable for swimming pools	No	No
Watt	40W	80W
Flow rate for 30 mJ/cm ²	18 m ³ /h	22 m ³ /h
Max. pressure	3 bar	3 bar
Diameter	-	-
Length x width	360 mm	660 mm
Cable length	1,2 m	1,2 m
Diameter in outlet	-	-
Housing	-	-
Electrical load	230V AC 50/60 Hz	230V AC 50/60 Hz
Max. current	0,8 A	1,2 A
Lamp power	40W High-Output	80W High-Output
Lamp lifespan	12.000 h	12.000 h
Indicator	-	-
Spare parts		
Replacement lamp	RLM0020	RLM0021
Quartz glass	QS0005	QS0006
Electrical unit	EPM0020 SS	EPM0021 SS
Housing	-	-
Item no.	UVM0020SS	UVM0021SS



Discover the complete UV-C series

UV-C Module Amalgam

The function of a UV lamp in a pond or swimming pool

The primary function of a UV lamp in a pond or swimming pool is to control suspended algae, resulting in clear and clean water. Other terms for a UV lamp include UV clarifier and UV sterilizer.



✓ Sustainable production

✓ 40 years experience

✓ Private label / custom solutions

The operation is as follows:

UV lamp is effective in keeping pond water clear by controlling suspended algae, but it also helps reduce excess nutrients and other causes of algae blooms. We therefore always recommend installing a UV-C lamp in combination with a filter, such as a drum filter, for your pond.

Control of suspended algae:

When pond water containing suspended algae flows through a UV unit, it is exposed to ultraviolet light. This damages the DNA of the algae, causing them to die and clump together.

Clumping:

As a result of UV exposure, the dead algae aggregate into larger particles.

Filtration:

These larger particles can then be more easily removed by the pond filter. As the water passes through the filter, the particles are screened out, leaving the water clear.

Reduction of pathogens:

In addition to controlling suspended algae, a UV lamp also helps reduce harmful pathogens and bacteria in the water. This promotes a healthy environment for flora and fauna in and around the pond.

UV-C LINE Module Amalgam

The Filtreau UV-C Module ensures crystal-clear water. Its advanced design and high-quality materials generate a high level of UV-C radiation at a precise wavelength of 253.7 nm. This high irradiation dose eliminates virtually all bacteria, viruses and even fungi, resulting in clean and clear water. As a result, the use of added chemicals (such as chlorine) can be reduced by up to 80%, creating a more natural and healthier water environment.

Technical specifications



Product	Filtreau UV-C Module Amalgam 40W	Filtreau UV-C Module Amalgam 40W + Timer
Suitable for ponds	Yes	Yes
Suitable for swimming pools	No	No
Watt	40W	40W
Flow rate for 30 mJ/cm ²	18 m ³ /h	18 m ³ /h
Max. pressure	3 bar	3 bar
Diameter	-	-
Length × width	360 mm	360 mm
Cable length	1,2 m	1,2 m
Diameter in outlet		
Housing		
Electrical load	230V AC 50/60 Hz	230V AC 50/60 Hz
Max. current	1,2 A	1,2 A
Lamp power	40W Amalgam	40W Amalgam
Lamp lifespan	12.000 h	12.000 h
Indicator	No	Yes
Spare parts		
Replacement lamp	RLM0001	RLM0002
Quartz glass	QS0001	QS0002
Electrical unit	EPM0001	EPM0001
Housing		
Item no.	UVM0001	UVM0002



Discover the complete UV-C series

UV-C Module Amalgam

The function of a UV lamp in a pond or swimming pool

The primary function of a UV lamp in a pond or swimming pool is to control suspended algae, resulting in clear and clean water. Other terms for a UV lamp include UV clarifier and UV sterilizer.



✔ Sustainable production

✔ 40 years experience

✔ Private label / custom solutions

The operation is as follows:

UV lamp is effective in keeping pond water clear by controlling suspended algae, but it also helps reduce excess nutrients and other causes of algae blooms. We therefore always recommend installing a UV-C lamp in combination with a filter, such as a drum filter, for your pond.

Control of suspended algae:

When pond water containing suspended algae flows through a UV unit, it is exposed to ultraviolet light. This damages the DNA of the algae, causing them to die and clump together.

Clumping:

As a result of UV exposure, the dead algae aggregate into larger particles.

Filtration:

These larger particles can then be more easily removed by the pond filter. As the water passes through the filter, the particles are screened out, leaving the water clear.

Reduction of pathogens:

In addition to controlling suspended algae, a UV lamp also helps reduce harmful pathogens and bacteria in the water. This promotes a healthy environment for flora and fauna in and around the pond.

UV-C LINE Module Amalgam

The Filtreau UV-C Module ensures crystal-clear water. Its advanced design and high-quality materials generate a high level of UV-C radiation at a precise wavelength of 253.7 nm. This high irradiation dose eliminates virtually all bacteria, viruses and even fungi, resulting in clean and clear water. As a result, the use of added chemicals (such as chlorine) can be reduced by up to 80%, creating a more natural and healthier water environment.

Technical specifications



Product	Filtreau UV-C Module Amalgam 80W	Filtreau UV-C Module Amalgam 80W + Timer
Suitable for ponds	Yes	Yes
Suitable for swimming pools	No	No
Watt	80W	80W
Flow rate for 30 mJ/cm ²	22 m ³ /h	22 m ³ /h
Max. pressure	3.0 bar	3.0 bar
Diameter	-	-
Length × width	660 mm	660 mm
Cable length	1,2 m	1,2 m
Diameter in outlet	-	-
Housing	-	-
Electrical load	230V AC 50/60 Hz	230V AC 50/60 Hz
Max. current	1,2 A	1,2 A
Lamp power	80W Amalgam	80W Amalgam
Lamp lifespan	12.000 h	12.000 h
Indicator	No	Yes
Spare parts		
Replacement lamp	RLM0002	RLM0002
Quartz glass	QS0001	QS0003
Electrical unit	EPM0003	EPM0004
Housing	-	-
Item no.	UVM0003	UVM0004



Discover the complete UV-C series

UV-C Module High Output

The function of a UV lamp in a pond or swimming pool

The primary function of a UV lamp in a pond or swimming pool is to control suspended algae, resulting in clear and clean water. Other terms for a UV lamp include UV clarifier and UV sterilizer.

Suitable for various applications +

+ Highly effective in killing microorganisms

Fast and efficient disinfection +

+ Do not require chemicals



✔ Sustainable production

✔ 40 years experience

✔ Private label / custom solutions

The operation is as follows:

UV lamp is effective in keeping pond water clear by controlling suspended algae, but it also helps reduce excess nutrients and other causes of algae blooms. We therefore always recommend installing a UV-C lamp in combination with a filter, such as a drum filter, for your pond.

Control of suspended algae:

When pond water containing suspended algae flows through a UV unit, it is exposed to ultraviolet light. This damages the DNA of the algae, causing them to die and clump together.

Clumping:

As a result of UV exposure, the dead algae aggregate into larger particles.

Filtration:

These larger particles can then be more easily removed by the pond filter. As the water passes through the filter, the particles are screened out, leaving the water clear.

Reduction of pathogens:

In addition to controlling suspended algae, a UV lamp also helps reduce harmful pathogens and bacteria in the water. This promotes a healthy environment for flora and fauna in and around the pond.

UV-C LINE Module High Output

The Filtreau UV-C Module ensures crystal-clear water. Its advanced design and high-quality materials generate a high level of UV-C radiation at a precise wavelength of 253.7 nm. This high irradiation dose eliminates virtually all bacteria, viruses and even fungi, resulting in clean and clear water. As a result, the use of added chemicals (such as chlorine) can be reduced by up to 80%, creating a more natural and healthier water environment.

Technical specifications



Product	Filtreau UV-C Module High Output 40W	Filtreau UV-C Module High Output 80W
Suitable for ponds	Yes	Yes
Suitable for swimming pools	No	No
Watt	40W	80W
Flow rate for 30 mJ/cm ²	18 m ³ /h	22 m ³ /h
Max. pressure	3.0 bar	3.0 bar
Diameter	-	-
Length × width	660 mm	660 mm
Cable length	1,2 m	1,2 m
Diameter in outlet	-	-
Housing	-	-
Electrical load	230V AC 50/60 Hz	230V AC 50/60 Hz
Max. current	0,8 A	0,8 A
Lamp power	40W High-Output	80W High-Output
Lamp lifespan	12.000 h	12.000 h
Indicator	-	-
Spare parts		
Replacement lamp	RLM0020	RLM0021
Quartz glass	QS0001	QS0003
Electrical unit	EPM0020	EPM0021
Housing	-	-
Item no.	UVM0020	UVM0021



Discover the complete UV-C series

UV-C Ozone

The function of a UV lamp in a pond or swimming pool

The primary function of a UV lamp in a pond or swimming pool is to control suspended algae, resulting in clear and clean water. Other terms for a UV lamp include UV clarifier and UV sterilizer.

Suitable for various applications



Highly effective in killing microorganisms

Fast and efficient disinfection



Do not require chemicals

✔ Sustainable production

✔ 40 years experience

✔ Private label / custom solutions

The operation is as follows:

UV lamp is effective in keeping pond water clear by controlling suspended algae, but it also helps reduce excess nutrients and other causes of algae blooms. We therefore always recommend installing a UV-C lamp in combination with a filter, such as a drum filter, for your pond.

Control of suspended algae:

When pond water containing suspended algae flows through a UV unit, it is exposed to ultraviolet light. This damages the DNA of the algae, causing them to die and clump together.

Clumping:

As a result of UV exposure, the dead algae aggregate into larger particles.

Filtration:

These larger particles can then be more easily removed by the pond filter. As the water passes through the filter, the particles are screened out, leaving the water clear.

Reduction of pathogens:

In addition to controlling suspended algae, a UV lamp also helps reduce harmful pathogens and bacteria in the water. This promotes a healthy environment for flora and fauna in and around the pond.

UV-C LINE Ozone

Ozone is one of the most effective sterilizing agents for water treatment. It has a very strong oxidizing and sterilizing capacity for all organic substances and eliminates unpleasant odors. Due to these properties, ozone has been used for decades to disinfect drinking water and air, and it is widely applied in the food industry.

Technical specifications



Product	Filtreau UV-C Ozone 80W	Filtreau UV-C Ozone (Salt Res.) 120W	Filtreau UV-C Ozone 16W
Suitable for ponds	Yes	Yes	Yes
Suitable for swimming pools	Yes	Yes	No
Watt	80W	120W	16W
Flow rate for 30 mJ/cm ²	80m ³	120m ³	15m ³
Ozonproductie	0,8 gr/h	1,2 gr/h	0,2 gr/h
Max. pressure	1 bar	1 bar	1 bar
Diameter	90 mm Ø	90 mm Ø	-
Length x width	970 x 155 mm	970 x 155 mm	395 x 155 mm
Cable length	1,2 m	1,2 m	1,2 m
Diameter in outlet	63	63	-
Housing	Duplex	Duplex	Duplex
Electrical load	230V AC 50/60 Hz	230V AC 50/60 Hz	230V AC 50/60 Hz
Max. current	0,8A	1,2A	-
Lamp power	80W	120W	16W
Lamp lifespan	8.000 h	8.000 h	8.000 h
Indicator	√	√	-
Spare parts			
Replacement lamp	RLO0001	RLO0002	RLOZ001
Quartz glass	QS0004	QS0004	-
Electrical unit	EPO0001	EPO0002	EPO0016
Housing	HOU0010	HOU0010	HOU0019
Item no.	UVO0001	UVO0002	O20N01



Discover the complete UV-C series

UV-C Pond Basic

The function of a UV lamp in a pond or swimming pool

The primary function of a UV lamp in a pond or swimming pool is to control suspended algae, resulting in clear and clean water. Other terms for a UV lamp include UV clarifier and UV sterilizer.

Suitable for various applications +

+ Highly effective in killing microorganisms



Fast and efficient disinfection +

+ Do not require chemicals

✔ Sustainable production

✔ 40 years experience

✔ Private label / custom solutions

The operation is as follows:

UV lamp is effective in keeping pond water clear by controlling suspended algae, but it also helps reduce excess nutrients and other causes of algae blooms. We therefore always recommend installing a UV-C lamp in combination with a filter, such as a drum filter, for your pond.

Control of suspended algae:

When pond water containing suspended algae flows through a UV unit, it is exposed to ultraviolet light. This damages the DNA of the algae, causing them to die and clump together.

Clumping:

As a result of UV exposure, the dead algae aggregate into larger particles.

Filtration:

These larger particles can then be more easily removed by the pond filter. As the water passes through the filter, the particles are screened out, leaving the water clear.

Reduction of pathogens:

In addition to controlling suspended algae, a UV lamp also helps reduce harmful pathogens and bacteria in the water. This promotes a healthy environment for flora and fauna in and around the pond.

UV-C LINE Pond Basic

The Filtreau UV-C Pond Basic ensures crystal-clear water. Its advanced design and high-quality materials generate a high level of UV-C radiation at a precise wavelength of 253.7 nm. This high irradiation dose eliminates virtually all bacteria, viruses and even fungi, resulting in clean and clear water.

Technical specifications



Product	Filtreau UV-C Pond Basic 16W PHILIPS	Filtreau UV-C Pond Basic 40W PHILIPS	Filtreau UV-C Pond Basic 80W PHILIPS
Suitable for ponds	Yes	Yes	Yes
Suitable for swimming pools	No	No	No
Watt	16W	40W	80W
Flow rate for 30 mJ/cm ²	12 m ³ /h	18 m ³ /h	22 m ³ /h
Max. pressure	3.0 bar	3.0 bar	3.0 bar
Diameter	88.9 mm	88.9 mm	88.9 mm
Length × width	540 mm	960 mm	960 mm
Cable length	1,2 m	1,2 m	1,2 m
Diameter in outlet	63/50/40/32/25 mm	63/50/40/32/25 mm	63/50/40/32/25 mm
Housing	SS 304	SS 304	SS 304
Electrical load	230V AC 50/60 Hz	230V AC 50/60 Hz	230V AC 50/60 Hz
Max. current	0,425 A	0,425 A	0,8 A
Lamp power	16W	40W	75W
Lamp lifespan	9.000 h	9.000 h	9.000 h
Indicator	-	-	-
Spare parts			
Replacement lamp	RLB0001	RLB0002	RLB0003
Quartz glass	QS0001	QS0002	QS0002
Electrical unit	EPB0001	EPB0002	EPB0003
Housing	HOU0001	HOU0002	HOU0002
Item no.	UVB0001	UVB0002	UVB0003



Discover the
complete UV-C
series

UV-C Pool Basic

The function of a UV lamp in a pond or swimming pool

The primary function of a UV lamp in a pond or swimming pool is to control suspended algae, resulting in clear and clean water. Other terms for a UV lamp include UV clarifier and UV sterilizer.

Suitable for various applications



Highly effective in killing microorganisms



Fast and efficient disinfection



Do not require chemicals



Philips Replacement lamps



✔ Sustainable production

✔ 40 years experience

✔ Private label / custom solutions

The operation is as follows:

UV lamp is effective in keeping pond water clear by controlling suspended algae, but it also helps reduce excess nutrients and other causes of algae blooms. We therefore always recommend installing a UV-C lamp in combination with a filter, such as a drum filter, for your pond.

Control of suspended algae:

When pond water containing suspended algae flows through a UV unit, it is exposed to ultraviolet light. This damages the DNA of the algae, causing them to die and clump together.

Clumping:

As a result of UV exposure, the dead algae aggregate into larger particles.

Filtration:

These larger particles can then be more easily removed by the pond filter. As the water passes through the filter, the particles are screened out, leaving the water clear.

Reduction of pathogens:

In addition to controlling suspended algae, a UV lamp also helps reduce harmful pathogens and bacteria in the water. This promotes a healthy environment for flora and fauna in and around the pond.

UV-C LINE Pool Basic

The Filtreau UV-C Pool Basic ensures crystal-clear water. Its advanced design and high-quality materials generate a high level of UV-C radiation at a precise wavelength of 253.7 nm. This high irradiation dose eliminates virtually all bacteria, viruses and even fungi, resulting in clean and clear water. As a result, the use of added chemicals (such as chlorine) can be reduced by up to 80%, creating a more natural and healthier water environment.

Technical specifications



Product	Filtreau UV-C Pool Basic 16W Philips	Filtreau UV-C Pool Basic 40W Philips	Filtreau UV-C Pool Basic 80W Philips
Suitable for ponds	No	No	No
Suitable for swimming pools	Yes	Yes	Yes
Watt	16W	40W	80W
Flow rate for 30 mJ/cm ²	12 m ³ /h	18 m ³ /h	22 m ³ /h
Max. pressure	3.0 bar	3.0 bar	3.0 bar
Diameter	88.9 mm	88.9 mm	88.9 mm
Length × width	600 mm	1.000 mm	1.000 mm
Cable length	1,2 m	1,2 m	1,2 m
Diameter in outlet	63/50/40/32/25 mm	63/50/40/32/25 mm	63/50/40/32/25 mm
Housing	SS 316	SS 316	SS 316
Electrical load	230V AC 50/60 Hz	230V AC 50/60 Hz	230V AC 50/60 Hz
Max. current	0,425 A	0,425 A	0,8 A
Lamp power	16W	40W	80W
Lamp lifespan	9.000 h	9.000 h	9.000 h
Indicator	-	-	-
Spare parts			
Replacement lamp	RLB0001	RLB0002	RLB0003
Quartz glass	QS0001	QS0002	QS0002
Electrical unit	EPB0004	EPB0005	EPB0006
Housing	HOU0001	HOU0002	HOU0002
Item no.	UVB0004	UVB0005	UVB0006



Discover the
complete UV-C
series

UV-C Salt Water

The function of a UV lamp in a pond or swimming pool

The primary function of a UV lamp in a pond or swimming pool is to control suspended algae, resulting in clear and clean water. Other terms for a UV lamp include UV clarifier and UV sterilizer.

Suitable for various applications 



 Highly effective in killing microorganisms

 Do not require chemicals

Fast and efficient disinfection 

 Sustainable production

 40 years experience

 Private label / custom solutions

The operation is as follows:

UV lamp is effective in keeping pond water clear by controlling suspended algae, but it also helps reduce excess nutrients and other causes of algae blooms. We therefore always recommend installing a UV-C lamp in combination with a filter, such as a drum filter, for your pond.

Control of suspended algae:

When pond water containing suspended algae flows through a UV unit, it is exposed to ultraviolet light. This damages the DNA of the algae, causing them to die and clump together.

Clumping:

As a result of UV exposure, the dead algae aggregate into larger particles.

Filtration:

These larger particles can then be more easily removed by the pond filter. As the water passes through the filter, the particles are screened out, leaving the water clear.

Reduction of pathogens:

In addition to controlling suspended algae, a UV lamp also helps reduce harmful pathogens and bacteria in the water. This promotes a healthy environment for flora and fauna in and around the pond.

UV-C LINE Salt Water

The Filtreau UV-C SALT ensures crystal-clear water. With its advanced design and high-quality materials, the unit generates a high level of UV-C radiation at a precise wavelength of 253.7 nm. This high radiation level eliminates virtually all bacteria, viruses and even fungi, resulting in clean and clear water. The 3 mm thick PVC housing has a diameter of 75 mm. Thanks to its compact design and three different connection options (including a bottom outlet), the unit ensures a space-saving installation, suitable even for the smallest installation spaces.

Technical specifications



Product	Filtreau UV-C Salt Water 16W	Filtreau UV-C Salt Water 40W	Filtreau UV-C Salt Water 80W
Suitable for ponds	Yes	Yes	Yes
Suitable for swimming pools	Yes	Yes	Yes
Watt	16W	40W	80W
Flow rate for 30 mJ/cm ²	18 m ³ /h	22 m ³ /h	28 m ³ /h
Max. pressure	3.0 bar	3.0 bar	3.0 bar
Diameter	75 mm	75 mm	75 mm
Length × width	550 mm	960 mm	960 mm
Cable length	1,2 m	1,2 m	1,2 m
Diameter in outlet	63 mm	63 mm	63 mm
Housing	PVC	PVC	PVC
Electrical load	230V AC 50/60 Hz	230V AC 50/60 Hz	230V AC 50/60 Hz
Max. current	0,425A	0,425A	0,8A
Lamp power	16W	40W	80W
Lamp lifespan	12.000 h	12.000 h	12.000 h
Indicator	-	-	-
Spare parts			
Replacement lamp	RLE0001	RLS0001	RLS0002
Quartz glass	QS0001	QS0002	QS0002
Electrical unit	EPSA01	EPSA02	EPSA03
Housing	HOU0017	HOU0018	HOU0018
Item no.	UVSA001	UVSA002	UVSA003



Filters are supplied without mats and Hel-X. These are available as optional extras.



Discover the complete UV-C series

UV-C Select

The function of a UV lamp in a pond or swimming pool

The primary function of a UV lamp in a pond or swimming pool is to control suspended algae, resulting in clear and clean water. Other terms for a UV lamp include UV clarifier and UV sterilizer.

Suitable for various applications +



+ Highly effective in killing microorganisms

Fast and efficient disinfection +

+ Do not require chemicals

✔ Sustainable production

✔ 40 years experience

✔ Private label / custom solutions

The operation is as follows:

UV lamp is effective in keeping pond water clear by controlling suspended algae, but it also helps reduce excess nutrients and other causes of algae blooms. We therefore always recommend installing a UV-C lamp in combination with a filter, such as a drum filter, for your pond.

Control of suspended algae:

When pond water containing suspended algae flows through a UV unit, it is exposed to ultraviolet light. This damages the DNA of the algae, causing them to die and clump together.

Clumping:

As a result of UV exposure, the dead algae aggregate into larger particles.

Filtration:

These larger particles can then be more easily removed by the pond filter. As the water passes through the filter, the particles are screened out, leaving the water clear.

Reduction of pathogens:

In addition to controlling suspended algae, a UV lamp also helps reduce harmful pathogens and bacteria in the water. This promotes a healthy environment for flora and fauna in and around the pond.

UV-C LINE Select

The Filtreau UV-C Select ensures crystal-clear water. Its advanced design and high-quality materials generate a high level of UV-C radiation at a precise wavelength of 253.7 nm. This high irradiation dose eliminates virtually all bacteria, viruses and even fungi, resulting in clean and clear water. As a result, the use of added chemicals (such as chlorine) can be reduced by up to 80%, creating a more natural and healthier water environment.

Technical specifications



Product	Filtreau UV-C Select 40W	Filtreau UV-C Select 80W	Filtreau UV-C Select 120W Amalgam
Suitable for ponds	Yes	Yes	Yes
Suitable for swimming pools	Yes	Yes	Yes
Watt	40W	80W	120W
Flow rate for 30 mJ/cm ²	18 m ³ /h	22 m ³ /h	28 m ³ /h
Max. pressure	3.0 bar	3.0 bar	3.0 bar
Diameter	88.9 mm	88.9 mm	88.9 mm
Length × width	960 mm	960 mm	960 mm
Cable length	1,2 m	1,2 m	1,2 m
Diameter in outlet	63 mm	63 mm	63 mm
Housing	SS 316	SS 316	SS 316
Electrical load	230V AC 50/60 Hz	230V AC 50/60 Hz	230V AC 50/60 Hz
Max. current	0,425 A	0,8 A	1.2 A
Lamp power	40W	80W	120W Amalgam
Lamp lifespan	12.000 h	12.000 h	12.000 h
Indicator	Yes	Yes	Yes
Spare parts			
Replacement lamp	RLS0001	RLS0002	RLS0003
Quartz glass	QS0002	QS0002	QS0002
Electrical unit	EPS0001	EPS0002	EPS0003
Housing	HOU0004	HOU0004	HOU0004
Item no.	UVS0001	UVS0002	UVS0003



Discover the complete UV-C series

UV-C Slim

The function of a UV lamp in a pond or swimming pool

The primary function of a UV lamp in a pond or swimming pool is to control suspended algae, resulting in clear and clean water. Other terms for a UV lamp include UV clarifier and UV sterilizer.

Suitable for various applications



Highly effective in killing microorganisms

Fast and efficient disinfection



Do not require chemicals

✔ Sustainable production

✔ 40 years experience

✔ Private label / custom solutions

The operation is as follows:

UV lamp is effective in keeping pond water clear by controlling suspended algae, but it also helps reduce excess nutrients and other causes of algae blooms. We therefore always recommend installing a UV-C lamp in combination with a filter, such as a drum filter, for your pond.

Control of suspended algae:

When pond water containing suspended algae flows through a UV unit, it is exposed to ultraviolet light. This damages the DNA of the algae, causing them to die and clump together.

Clumping:

As a result of UV exposure, the dead algae aggregate into larger particles.

Filtration:

These larger particles can then be more easily removed by the pond filter. As the water passes through the filter, the particles are screened out, leaving the water clear.

Reduction of pathogens:

In addition to controlling suspended algae, a UV lamp also helps reduce harmful pathogens and bacteria in the water. This promotes a healthy environment for flora and fauna in and around the pond.

UV-C LINE Slim

The Filtreau UV-C Slim ensures crystal-clear water. With its advanced design and high-quality materials, the unit generates a high level of UV-C radiation at a precise wavelength of 253.7 nm. This high radiation level eliminates virtually all bacteria, viruses and even fungi, resulting in clean and clear water. As a result, the amount of added chemicals (such as chlorine) can be reduced by up to 80%, creating a more natural and healthier water environment.

Technical specifications



Product	Filtreau UV-C Slim 40W	Filtreau UV-C Slim 80W
Suitable for ponds	No	No
Suitable for swimming pools	Yes	Yes
Watt	40W	80W
Flow rate for 30 mJ/cm ²	40m ³	80m ³
Max. pressure	3 bar	3 bar
Diameter	70 mm Ø	70 mm Ø
Length x width	960 mm	960 mm
Cable length	1,2 m	1,2 m
Diameter in outlet	63/50/40/32/25	63/50/40/32/25
Housing	SS 316	SS 316
Electrical load	230V AC 50/60 Hz	230V AC 50/60 Hz
Max. current	0,425A	0,8A
Lamp power	40W	80W
Lamp lifespan	12.000 h	12.000 h
Indicator	-	-
Spare parts		
Replacement lamp	RLSL002	RLSL003
Quartz glass	QS0002	QS0002
Electrical unit	EPSL002	EPSL003
Housing	HOU0014	HOU0014
Item no.	UVSL002	UVSL003



Discover the complete UV-C series

UV-C Spa Unit

The function of a UV lamp in a pond or swimming pool

The primary function of a UV lamp in a pond or swimming pool is to control suspended algae, resulting in clear and clean water. Other terms for a UV lamp include UV clarifier and UV sterilizer.

Suitable for various applications +

Fast and efficient disinfection +



+ Highly effective in killing microorganisms

+ Do not require chemicals

✔ Sustainable production

✔ 40 years experience

✔ Private label / custom solutions

The operation is as follows:

UV lamp is effective in keeping pond water clear by controlling suspended algae, but it also helps reduce excess nutrients and other causes of algae blooms. We therefore always recommend installing a UV-C lamp in combination with a filter, such as a drum filter, for your pond.

Control of suspended algae:

When pond water containing suspended algae flows through a UV unit, it is exposed to ultraviolet light. This damages the DNA of the algae, causing them to die and clump together.

Clumping:

As a result of UV exposure, the dead algae aggregate into larger particles.

Filtration:

These larger particles can then be more easily removed by the pond filter. As the water passes through the filter, the particles are screened out, leaving the water clear.

Reduction of pathogens:

In addition to controlling suspended algae, a UV lamp also helps reduce harmful pathogens and bacteria in the water. This promotes a healthy environment for flora and fauna in and around the pond.

UV-C LINE Spa Unit

The Filtreau UV-C Spa is ideally suited for jacuzzis. The remaining bacteria that cannot be effectively treated by chlorine (from salt systems) are eliminated by the UV-C radiation. The UV-C Spa therefore serves as an essential addition to your disinfection system in a jacuzzi. The Filtreau UV-C Spa is installed as the final component in the system, after which the water flows back into the jacuzzi.

Technical specifications



Product	Filtreau UV-C Spa Unit 10W
Suitable for ponds	No
Suitable for swimming pools	No
Watt	10W
Flow rate for 30 mJ/cm ²	-
Max. pressure	2 bar
Diameter	-
Length x width	230 x 155 mm
Cable length	1200 mm
Diameter in outlet	1,2 m
Housing	PVC
Electrical load	230V AC 50/60 Hz
Max. current	-
Lamp power	10W
Lamp lifespan	9.000 h
Indicator	-
Spare parts	
Replacement lamp	RLSP01
Quartz glass	QS0008
Electrical unit	EPSP01
Housing	HOUSP01
Item no.	UVSPA01



Discover the
complete UV-C
series

UV-C Titan

The function of a UV lamp in a pond or swimming pool

The primary function of a UV lamp in a pond or swimming pool is to control suspended algae, resulting in clear and clean water. Other terms for a UV lamp include UV clarifier and UV sterilizer.

Suitable for various applications



Highly effective in killing microorganisms



Fast and efficient disinfection



Do not require chemicals

✔ Sustainable production

✔ 40 years experience

✔ Private label / custom solutions

The operation is as follows:

UV lamp is effective in keeping pond water clear by controlling suspended algae, but it also helps reduce excess nutrients and other causes of algae blooms. We therefore always recommend installing a UV-C lamp in combination with a filter, such as a drum filter, for your pond.

Control of suspended algae:

When pond water containing suspended algae flows through a UV unit, it is exposed to ultraviolet light. This damages the DNA of the algae, causing them to die and clump together.

Clumping:

As a result of UV exposure, the dead algae aggregate into larger particles.

Filtration:

These larger particles can then be more easily removed by the pond filter. As the water passes through the filter, the particles are screened out, leaving the water clear.

Reduction of pathogens:

In addition to controlling suspended algae, a UV lamp also helps reduce harmful pathogens and bacteria in the water. This promotes a healthy environment for flora and fauna in and around the pond.

UV-C LINE Titan

The Filtreau UV-C Titan ensures crystal-clear water. Its advanced design and high-quality materials generate a high level of UV-C radiation at a precise wavelength of 253.7 nm. This high irradiation dose eliminates virtually all bacteria, viruses and even fungi, resulting in clean and clear water. As a result, the use of added chemicals (such as chlorine) can be reduced by up to 80%, creating a more natural and healthier water environment.

Technical specifications



Product	Filtreau UV-C Titan (Salt Res.) 40W	Filtreau UV-C Titan (Salt Res.) 80W	Filtreau UV-C Titan (Salt Res.) 120W
Suitable for ponds	No	No	No
Suitable for swimming pools	Yes	Yes	Yes
Watt	40W	80W	120W
Flow rate for 30 mJ/cm ²	18 m ³ /h	22 m ³ /h	28 m ³ /h
Max. pressure	3.0 bar	3.0 bar	3.0 bar
Diameter	88.9 mm	88.9 mm	88.9 mm
Length × width	1.000 mm	1.000 mm	1.000 mm
Cable length	1,2 m	1,2 m	1,2 m
Diameter in outlet	63 mm	63 mm	63 mm
Housing	Duplex	Duplex	Duplex
Electrical load	230V AC 50/60 Hz	230V AC 50/60 Hz	230V AC 50/60 Hz
Max. current	0,425 A	0,425 A	0,425 A
Lamp power	40W	80W	120W Amalgam
Lamp lifespan	12.000 h	12.000 h	12.000 h
Indicator	Yes	Yes	Yes
Spare parts			
Replacement lamp	RLS0001	RLS0002	RLS0003
Quartz glass	QS0002	QS0002	QS0002
Electrical unit	-	-	-
Housing	HOU0006	HOU0006	HOU0006
Item no.	UVT0001	UVT0002	UVT0003



Discover the complete UV-C series

UV-C PRO INOX

The function of a UV lamp in a pond or swimming pool

The primary function of a UV lamp in a pond or swimming pool is to control suspended algae, resulting in clear and clean water. Other terms for a UV lamp include UV clarifier and UV sterilizer.

Suitable for various applications



Highly effective in killing microorganisms

Fast and efficient disinfection



Do not require chemicals



✔ Sustainable production

✔ 40 years experience

✔ Private label / custom solutions

The operation is as follows:

UV lamp is effective in keeping pond water clear by controlling suspended algae, but it also helps reduce excess nutrients and other causes of algae blooms. We therefore always recommend installing a UV-C lamp in combination with a filter, such as a drum filter, for your pond.

Control of suspended algae:

When pond water containing suspended algae flows through a UV unit, it is exposed to ultraviolet light. This damages the DNA of the algae, causing them to die and clump together.

Clumping:

As a result of UV exposure, the dead algae aggregate into larger particles.

Filtration:

These larger particles can then be more easily removed by the pond filter. As the water passes through the filter, the particles are screened out, leaving the water clear.

Reduction of pathogens:

In addition to controlling suspended algae, a UV lamp also helps reduce harmful pathogens and bacteria in the water. This promotes a healthy environment for flora and fauna in and around the pond.

UV-C LINE PRO INOX

The Filtreau PRO INOX series is a professional UV-C range featuring INOX and HDPE units. It is constructed from high-quality materials and equipped with industrial-grade UV-C lamps with a long service life and a precise wavelength of 253.7 nm. This high irradiation dose eliminates virtually all bacteria, viruses and even fungi, resulting in clean and clear water. As a result, the use of added chemicals (such as chlorine) can be reduced by up to 80%, creating a more natural and healthier water environment.

Technical specifications

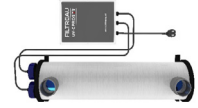
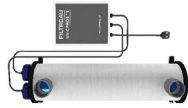

Product	Filtreau UV-C PRO INOX 80W	Filtreau UV-C PRO INOX 160W	Filtreau UV-C PRO INOX 240W
Suitable for ponds	Yes	Yes	Yes
Suitable for swimming pools	Yes	Yes	Yes
Max. pond volume	80m ³	160m ³	240m ³
Watt	80W	160W	240W
Flow rate for 30 mJ/cm ²	22 m ³ /h	22 m ³ /h	22 m ³ /h
Max. pressure	3.0 bar	3.0 bar	3.0 bar
Diameter	Ø 200 mm	Ø 200 mm	Ø 200 mm
Length x width	950 x 280 mm	950 x 280 mm	950 x 280 mm
Cable length	1,2 m	1,2 m	1,2 m
Diameter in outlet	75 mm	75 mm	75mm
Housing	Stainless steel 316	Stainless steel 316	Stainless steel 316
Electrical load	230V AC 50/60 Hz	230V AC 50/60 Hz	230V AC 50/60 Hz
Max. current	1,4 A	1,4 A	1,4 A
Lamp lifespan	9.000 h	9.000 h	9.000 h
Spare parts			
Housing	HOUIN0001	HOUIN0002	HOUIN0003
Replacement lamp	RLS0002	RLS0002 2x	RLS0002 3x
Quartz glass	QSI0002	QSI0002 2x	QSI0002 3x
Electrical part	EPPI0001	EPPI0002	EPPI0003
Item no.	UVP0001	UVP0002	UVP0003



Discover the complete UV-C series

UV-C PRO INOX

The function of a UV lamp in a pond or swimming pool

The primary function of a UV lamp in a pond or swimming pool is to control suspended algae, resulting in clear and clean water. Other terms for a UV lamp include UV clarifier and UV sterilizer.

Suitable for various applications



Highly effective in killing microorganisms

Fast and efficient disinfection



Do not require chemicals



✔ Sustainable production

✔ 40 years experience

✔ Private label / custom solutions

The operation is as follows:

UV lamp is effective in keeping pond water clear by controlling suspended algae, but it also helps reduce excess nutrients and other causes of algae blooms. We therefore always recommend installing a UV-C lamp in combination with a filter, such as a drum filter, for your pond.

Control of suspended algae:

When pond water containing suspended algae flows through a UV unit, it is exposed to ultraviolet light. This damages the DNA of the algae, causing them to die and clump together.

Clumping:

As a result of UV exposure, the dead algae aggregate into larger particles.

Filtration:

These larger particles can then be more easily removed by the pond filter. As the water passes through the filter, the particles are screened out, leaving the water clear.

Reduction of pathogens:

In addition to controlling suspended algae, a UV lamp also helps reduce harmful pathogens and bacteria in the water. This promotes a healthy environment for flora and fauna in and around the pond.

UV-C LINE PRO INOX

The Filtreau PRO INOX series is a professional UV-C range featuring INOX and HDPE units. Constructed from high-quality materials and equipped with industrial-grade UV-C lamps, the system offers a long service life and a precise wavelength of 253.7 nm. This high irradiation dose eliminates virtually all bacteria, viruses and even fungi, resulting in clean and clear water. As a result, the use of added chemicals (such as chlorine) can be reduced by up to 80%, creating a more natural and healthier water environment.

Technical specifications

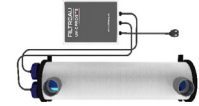
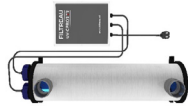

Product	Filtreau UV-C PRO INOX 105W	Filtreau UV-C PRO INOX 210W	Filtreau UV-C PRO INOX 315W
Suitable for ponds	Yes	Yes	Yes
Suitable for swimming pools	Yes	Yes	Yes
Max. pond volume	100m ³	200m ³	300m ³
Watt	105W	210W	315W
Flow rate for 30 mJ/cm ²	22 m ³ /h	22 m ³ /h	22 m ³ /h
Max. pressure	3.0 bar	3.0 bar	3.0 bar
Diameter	Ø 200 mm	Ø 200 mm	Ø 200 mm
Length x width	950 x 280 mm	950 x 280 mm	950 x 280 mm
Cable length	1,2 m mm	1,2 m mm	1,2 m mm
Diameter in outlet	75 mm	75 mm	75mm
Housing	Stainless steel 316	Stainless steel 316	Stainless steel 316
Electrical load	230V AC 50/60 Hz	230V AC 50/60 Hz	230V AC 50/60 Hz
Max. current	1,4 A	1,4 A	1,4 A
Lamp lifespan	13.000 h	13.000 h	13.000 h
Spare parts			
Housing	HOUIN0004	HOUIN0005	HOUIN0006
Replacement lamp	RLM0105	RLM0105 2x	RLM0105 3x
Quartz glass	QSI0002	QSI0002 2x	QSI0002 3x
Electrical part	EPPI0004	EPPI0005	EPPI0006
Item no.	UVP0004	UVP0005	UVP0006



Discover the complete UV-C series

UV-C PRO HDPE

The function of a UV lamp in a pond or swimming pool

The primary function of a UV lamp in a pond or swimming pool is to control suspended algae, resulting in clear and clean water. Other terms for a UV lamp include UV clarifier and UV sterilizer.



✔ Sustainable production

✔ 40 years experience

✔ Private label / custom solutions

The operation is as follows:

UV lamp is effective in keeping pond water clear by controlling suspended algae, but it also helps reduce excess nutrients and other causes of algae blooms. We therefore always recommend installing a UV-C lamp in combination with a filter, such as a drum filter, for your pond.

Control of suspended algae:

When pond water containing suspended algae flows through a UV unit, it is exposed to ultraviolet light. This damages the DNA of the algae, causing them to die and clump together.

Clumping:

As a result of UV exposure, the dead algae aggregate into larger particles.

Filtration:

These larger particles can then be more easily removed by the pond filter. As the water passes through the filter, the particles are screened out, leaving the water clear.

Reduction of pathogens:

In addition to controlling suspended algae, a UV lamp also helps reduce harmful pathogens and bacteria in the water. This promotes a healthy environment for flora and fauna in and around the pond.

UV-C LINE PRO HDPE

The Filtreau PRO HDPE series is a professional UV-C range featuring HDPE units. Suitable for aquaculture, chemical-resistant and saltwater-resistant. Constructed from high-quality materials and equipped with industrial-grade UV-C lamps with a long service life and a precise wavelength of 253.7 nm. This high irradiation dose eliminates virtually all bacteria, viruses and even fungi, resulting in clean and clear water.

Technical specifications

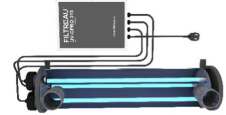
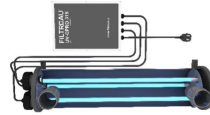
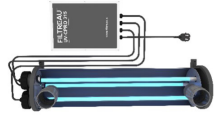

Product	Filtreau UV-C PRO HDPE 105W	Filtreau UV-C PRO HDPE 210W	Filtreau UV-C PRO HDPE 315W
Suitable for ponds	Yes	Yes	Yes
Suitable for swimming pools	Yes	Yes	Yes
Max. pond volume	100m ³	200m ³	300m ³
Watt	105W	210W	315W
Flow rate for 30 mJ/cm ²	22 m ³ /h	22 m ³ /h	22 m ³ /h
Max. pressure	3.0 bar	3.0 bar	3.0 bar
Diameter	Ø 200 mm	Ø 200 mm	Ø 200 mm
Length x width	950 x 280 mm	950 x 280 mm	950 x 280 mm
Cable length	1,2 m mm	1,2 m mm	1,2 m mm
Diameter in outlet	75 mm	75 mm	75mm
Housing	HDPE	HDPE	HDPE
Electrical load	230V AC 50/60 Hz	230V AC 50/60 Hz	230V AC 50/60 Hz
Max. current	1,4 A	1,4 A	1,4 A
Lamp lifespan	13.000 h	13.000 h	13.000 h
Spare parts			
Housing	HOUIN0007	HOUIN0008	HOUIN0009
Replacement lamp	RLM0105	RLM0105 2x	RLM0105 3x
Quartz glass	QSI0002	QSI0002	QSI0002
Electrical part	EPPI0007	EPPI0008	EPPI0009
Item no.	UVP0007	UVP0008	UVP0009



Discover the complete UV-C series

INDUSTRY STERILIZER UV-C Ballast

The function of a UV lamp in a pond or swimming pool

The primary function of a UV lamp in a pond or swimming pool is to control suspended algae, resulting in clear and clean water. Other terms for a UV lamp include UV clarifier and UV sterilizer.

BALLAST +

+ 25 Watt - 105 Watt

Universal +

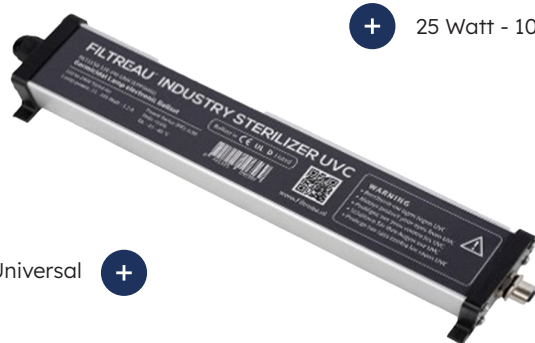

Universal



Industrial



Available in 5 wattages

The operation is as follows:

UV lamp is effective in keeping pond water clear by controlling suspended algae, but it also helps reduce excess nutrients and other causes of algae blooms. We therefore always recommend installing a UV-C lamp in combination with a filter, such as a drum filter, for your pond.

Control of suspended algae:

When pond water containing suspended algae flows through a UV unit, it is exposed to ultraviolet light. This damages the DNA of the algae, causing them to die and clump together.

Clumping:

As a result of UV exposure, the dead algae aggregate into larger particles.

Filtration:

These larger particles can then be more easily removed by the pond filter. As the water passes through the filter, the particles are screened out, leaving the water clear.

Reduction of pathogens:

In addition to controlling suspended algae, a UV lamp also helps reduce harmful pathogens and bacteria in the water. This promotes a healthy environment for flora and fauna in and around the pond.

UV-C LINE INDUSTRY STERILIZER

The Filtreau INDUSTRY STERILIZER series is a professional UV-C range equipped with a heavy-duty ballast and a 2-year warranty. 110–240 V, 50/60 Hz. 25–105 W. 1.2 A. The ballast is CE, UL and D certified. This high irradiation dose eliminates virtually all bacteria, viruses and even fungi, resulting in clean and clear water. As a result, the use of added chemicals (such as chlorine) can be reduced by up to 80%, creating a more natural and healthier water environment. The TPU cable is thermoplastic polyurethane, flexible and shock-absorbing.

Technical specifications SET



UV-C INDUSTRY STERILIZER	25W	40W	55W	75W	105W
EAN code	8721225106576	8721225106583	8721225106590	8721225106613	8721225106620
Lamp article code	RLI0001	RLI0002	RLI0003	RLI0003	RLI0003
Ballast	EPP0001	EPP0001	EPP0001	EPP0001	EPP0001
Length	260 mm	440 mm	560 mm	730 mm	930 mm



EPP0001



Connector



HOU0021



HOU0020



HOU0020



Lamp + HOU0021



Discover the complete UV-C series

BUDGET DIP INOX UV-C

The function of a UV lamp in a pond or swimming pool

The primary function of a UV lamp in a pond or swimming pool is to control suspended algae, resulting in clear and clean water. Other terms for a UV lamp include UV clarifier and UV sterilizer.



Universal



Industrial



Beschikbaar in 2 wattages

The operation is as follows:

UV lamp is effective in keeping pond water clear by controlling suspended algae, but it also helps reduce excess nutrients and other causes of algae blooms. We therefore always recommend installing a UV-C lamp in combination with a filter, such as a drum filter, for your pond.

Control of suspended algae:

When pond water containing suspended algae flows through a UV unit, it is exposed to ultraviolet light. This damages the DNA of the algae, causing them to die and clump together.

Clumping:

As a result of UV exposure, the dead algae aggregate into larger particles.

Filtration:

These larger particles can then be more easily removed by the pond filter. As the water passes through the filter, the particles are screened out, leaving the water clear.

Reduction of pathogens:

In addition to controlling suspended algae, a UV lamp also helps reduce harmful pathogens and bacteria in the water. This promotes a healthy environment for flora and fauna in and around the pond.

UV-C LINE BUDGET DIP INOX

The UV-C BUDGET DIP INOX is a reliable UV-C solution featuring an INOX stainless steel housing. The system is available in 40 W and 80 W and provides effective water disinfection by reducing bacteria, viruses and other microorganisms, keeping the water clear and hygienic. The unit is supplied with a 4.5 meter power cable for flexible installation. With a lamp service life of approximately 9,000 operating hours, the DIP UV-C offers long-lasting and stable performance. The UV-C lamp has a length of 670 mm and is available in both 40 W and 80 W versions.

Technical specifications SET



UV-C INDUSTRY STERILIZER	40W	80W
EAN code	8721225107061	8721225107092
Article number	UVD002	UVD003
Lamp/Quartz glass	UVM0010	UVM0011
Ballast	EPM0010	EPM0011
Lifespan	9.000h	9.000h
Length lamp	670 mm	670 mm



HOU0021



HOU0020



HOU0020



Discover the complete UV-C series

UV-C Aqua Culture Aquarium Sea Salt Resistant

The function of a UV lamp in a pond or swimming pool

The primary function of a UV lamp in a pond or swimming pool is to control suspended algae, resulting in clear and clean water. Other terms for a UV lamp include UV clarifier and UV sterilizer.



✓ Sustainable production

✓ 40 years experience

✓ Private label / custom solutions

The operation is as follows:

UV lamp is effective in keeping pond water clear by controlling suspended algae, but it also helps reduce excess nutrients and other causes of algae blooms. We therefore always recommend installing a UV-C lamp in combination with a filter, such as a drum filter, for your pond.

Control of suspended algae:

When pond water containing suspended algae flows through a UV unit, it is exposed to ultraviolet light. This damages the DNA of the algae, causing them to die and clump together.

Clumping:

As a result of UV exposure, the dead algae aggregate into larger particles.

Filtration:

These larger particles can then be more easily removed by the pond filter. As the water passes through the filter, the particles are screened out, leaving the water clear.

Reduction of pathogens:

In addition to controlling suspended algae, a UV lamp also helps reduce harmful pathogens and bacteria in the water. This promotes a healthy environment for flora and fauna in and around the pond.

UV-C LINE Aqua Culture Aquarium Sea Salt Resistant

The Filtreau SEA SALT HDPE Industry Sterilizer series is a professional UV-C range featuring SEA SALT and HDPE units. This high-quality UV-C unit is specifically developed for use in demanding marine environments. Thanks to its chemical- and saltwater-resistant HDPE housing, this product is perfectly suited for long-term use in applications such as marine aquariums, fish farming systems and other aquaculture installations. The combination of a robust design and high-quality components ensures maximum reliability and a long service life.

Technical specifications



Industry Sterilizer UVC SEA SALT HDPE	16W	40W + ballast	80W + ballast
EAN code	08721225106743	08721225106750	08721225106767
In/out let	25/32 mm	25/32 mm	25/32mm
Dimensions	450 x 150 mm	450 x 150 mm	780 x 150 mm
Diameter	ø 90 mm	ø 90 mm	ø 90 mm
Electrical part	16 Watt	25-105 Watt 1,4 A	25-105 Watt 1,4 A
Lamp lifespan	9.000h	13.000h	13.000h
Spare parts			
Quartz glass	QS0001	QS0001	QS0003
Replacement lamp	RLB0001	RLM0040	RLM0080
Electrical part	EPE0001	EPPI0002	EPPI0002
Item no.	UVHDPE016	UVHDPE040	UVHDPE080



**Discover the
complete UV-C
series**

UV-C PRO EXCELLENT INOX 316L

The function of a UV lamp in a pond or swimming pool

The primary function of a UV lamp in a pond or swimming pool is to control suspended algae, resulting in clear and clean water. Other terms for a UV lamp include UV clarifier and UV sterilizer.



☑ Sustainable production

☑ 40 years experience

☑ Private label / custom solutions

The operation is as follows:

UV lamp is effective in keeping pond water clear by controlling suspended algae, but it also helps reduce excess nutrients and other causes of algae blooms. We therefore always recommend installing a UV-C lamp in combination with a filter, such as a drum filter, for your pond.

Control of suspended algae:

When pond water containing suspended algae flows through a UV unit, it is exposed to ultraviolet light. This damages the DNA of the algae, causing them to die and clump together.

Clumping:

As a result of UV exposure, the dead algae aggregate into larger particles.

Filtration:

These larger particles can then be more easily removed by the pond filter. As the water passes through the filter, the particles are screened out, leaving the water clear.

Reduction of pathogens:

In addition to controlling suspended algae, a UV lamp also helps reduce harmful pathogens and bacteria in the water. This promotes a healthy environment for flora and fauna in and around the pond.

UV-C LINE PRO EXCELLENT INOX 316L

The Filtreau PRO EXCELLENT INOX series is a professional UV-C range. Constructed from high-quality materials and equipped with industrial-grade UV-C lamps, the system offers a long service life and a precise wavelength of 253.7 nm. This high irradiation dose eliminates virtually all bacteria, viruses and even fungi, resulting in clean and clear water. As a result, the use of added chemicals (such as chlorine) can be reduced by up to 80%, creating a more natural and healthier water environment.

Technical specifications

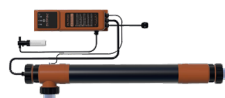
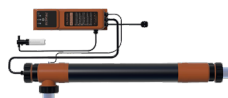

Product	Filtreau UV-C PRO EXCELLENT INOX 80W	Filtreau UV-C PRO EXCELLENT INOX 105W
Suitable for ponds	Yes	Yes
Suitable for swimming pools	Yes	Yes
Max. zwembad inhoud	80m ³	105m ³
Watt	80W	105W
Flow rate for 30 mJ/cm ²	22 m ³ /h	28 m ³ /h
Max. pressure	3.0 bar	3.0 bar
Diameter	Ø 88,9 mm	Ø 88,9 mm
Length x width	970 x 155 mm	970 x 155 mm
Cable length	1,2 m	1,2 m
Diameter in outlet	63 mm	63 mm
Housing	Stainless steel 316L	Stainless steel 316L
Electrical load	230V AC 50/60 Hz	230V AC 50/60 Hz
Max. current	0,8 A	1,4 A
Lamp lifespan	13.000 h	13.000 h
Spare parts		
Housing	HOU0025	HOU0025
Replacement lamp	RLEX0001	RLM0105
Quartz glass	QS0002	QS0002
Electrical part	EPEX002	EPEX003
Item no.	UVEX002	UVEX003



Discover the complete UV-C series

UV-C PRO EXCELLENT TITAN

The function of a UV lamp in a pond or swimming pool

The primary function of a UV lamp in a pond or swimming pool is to control suspended algae, resulting in clear and clean water. Other terms for a UV lamp include UV clarifier and UV sterilizer.

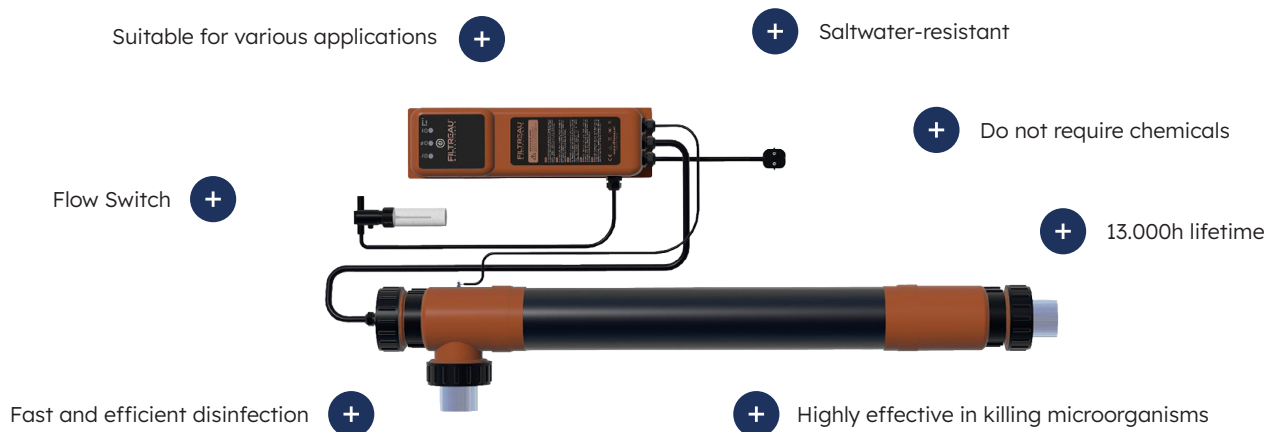

☑ Sustainable production

☑ 40 years experience

☑ Private label / custom solutions

The operation is as follows:

UV lamp is effective in keeping pond water clear by controlling suspended algae, but it also helps reduce excess nutrients and other causes of algae blooms. We therefore always recommend installing a UV-C lamp in combination with a filter, such as a drum filter, for your pond.

Control of suspended algae:

When pond water containing suspended algae flows through a UV unit, it is exposed to ultraviolet light. This damages the DNA of the algae, causing them to die and clump together.

Clumping:

As a result of UV exposure, the dead algae aggregate into larger particles.

Filtration:

These larger particles can then be more easily removed by the pond filter. As the water passes through the filter, the particles are screened out, leaving the water clear.

Reduction of pathogens:

In addition to controlling suspended algae, a UV lamp also helps reduce harmful pathogens and bacteria in the water. This promotes a healthy environment for flora and fauna in and around the pond.

UV-C LINE PRO EXCELLENT TITAN

The Filtreau PRO EXCELLENT INOX series is a professional UV-C range. Constructed from high-quality materials and equipped with industrial-grade UV-C lamps, it offers a long service life and a precise wavelength of 253.7 nm. This high irradiation dose eliminates virtually all bacteria, viruses and even fungi, resulting in clean and clear water. As a result, the use of added chemicals (such as chlorine) can be reduced by up to 80%, creating a more natural and healthier water environment.

Technical specifications

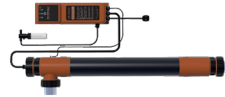
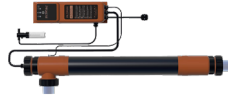

Product	Filtreau UV-C PRO EXCELLENT TITAN 80W	Filtreau UV-C PRO EXCELLENT TITAN 105W
Suitable for ponds	Yes	Yes
Suitable for swimming pools	Yes	Yes
Max. zwembad inhoud	80m ³	105m ³
Watt	80W	105W
Flow rate for 30 mJ/cm ²	22 m ³ /h	28 m ³ /h
Max. pressure	3.0 bar	3.0 bar
Diameter	Ø 88,9 mm	Ø 88,9 mm
Length x width	970 x 155 mm	970 x 155 mm
Cable length	1,2 m	1,2 m
Diameter in outlet	63 mm	63 mm
Housing	TITAN	TITAN
Electrical load	230V AC 50/60 Hz	230V AC 50/60 Hz
Max. current	0,8 A	1,4 A
Lamp lifespan	13.000 h	13.000 h
Spare parts		
Housing	HOU0026	HOU0026
Replacement lamp	RLEX001	RLM0105
Quartz glass	QS0002	QS0002
Electrical part	EPEX006	EPEX006
Item no.	UVEX006	UVEX007



Discover the complete UV-C series



Technical drawings

UV-C lamps in detail

UVC-LINE

Technical drawing UVC Inox Compact 16W / 40W / 75W

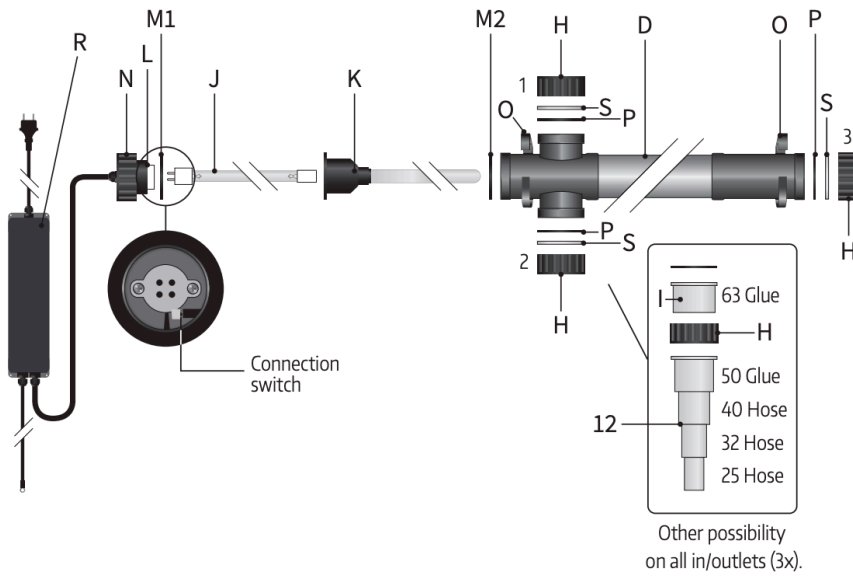

Components

- Housing (D)
- Lock nut (H)
- Connection coupling (I / I2)
- UV-C-lamp (J)
- Quartz glass (K)
- Lamp holder (L)
- O-rings (M1 & M2)
- Nut (N)
- Pipe clamps (O)
- O-rings (P)
- Electrical ballast (R)
- End caps (S)



[Download online](#)

UVC-LINE

Technical drawing UVC Inox Module 40W / 80W

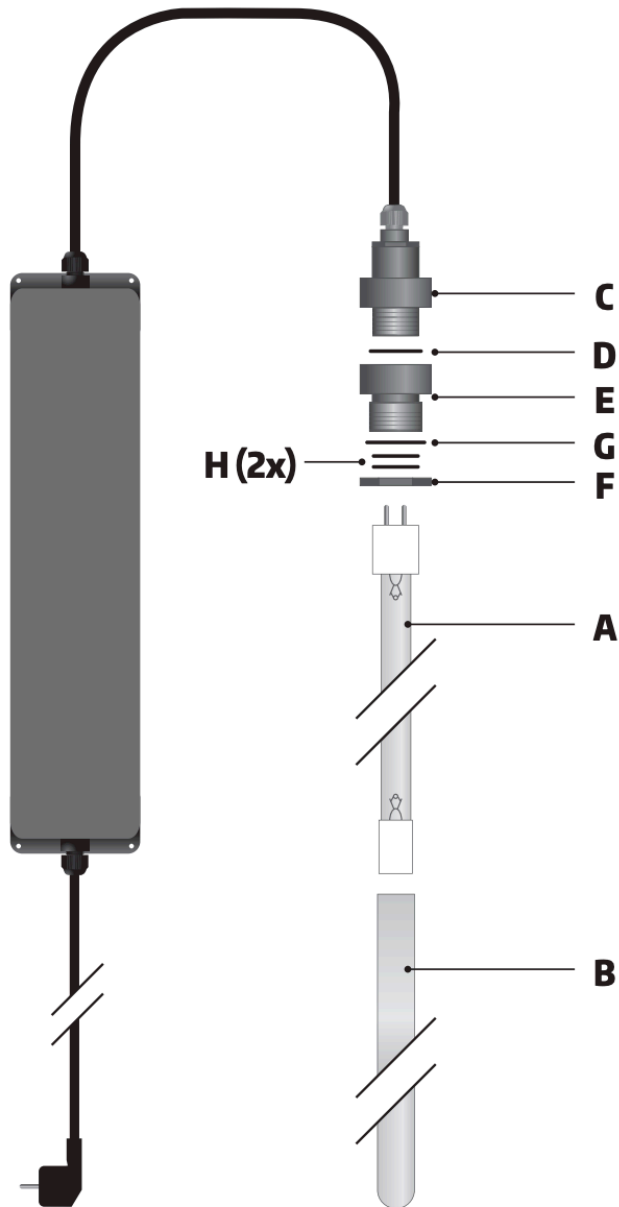

Components

- UV-C-lamp (A)
- Quartz glass (B)
- Lamp holder (C)
- O-ring (D)
- Quartz glass holder (E).
- Mounting nut (F).
- O-ring (G).
- O-rings (H).



[Download online](#)

UVC-LINE

Technical drawing POND BASIC 16W / 40W / 80W

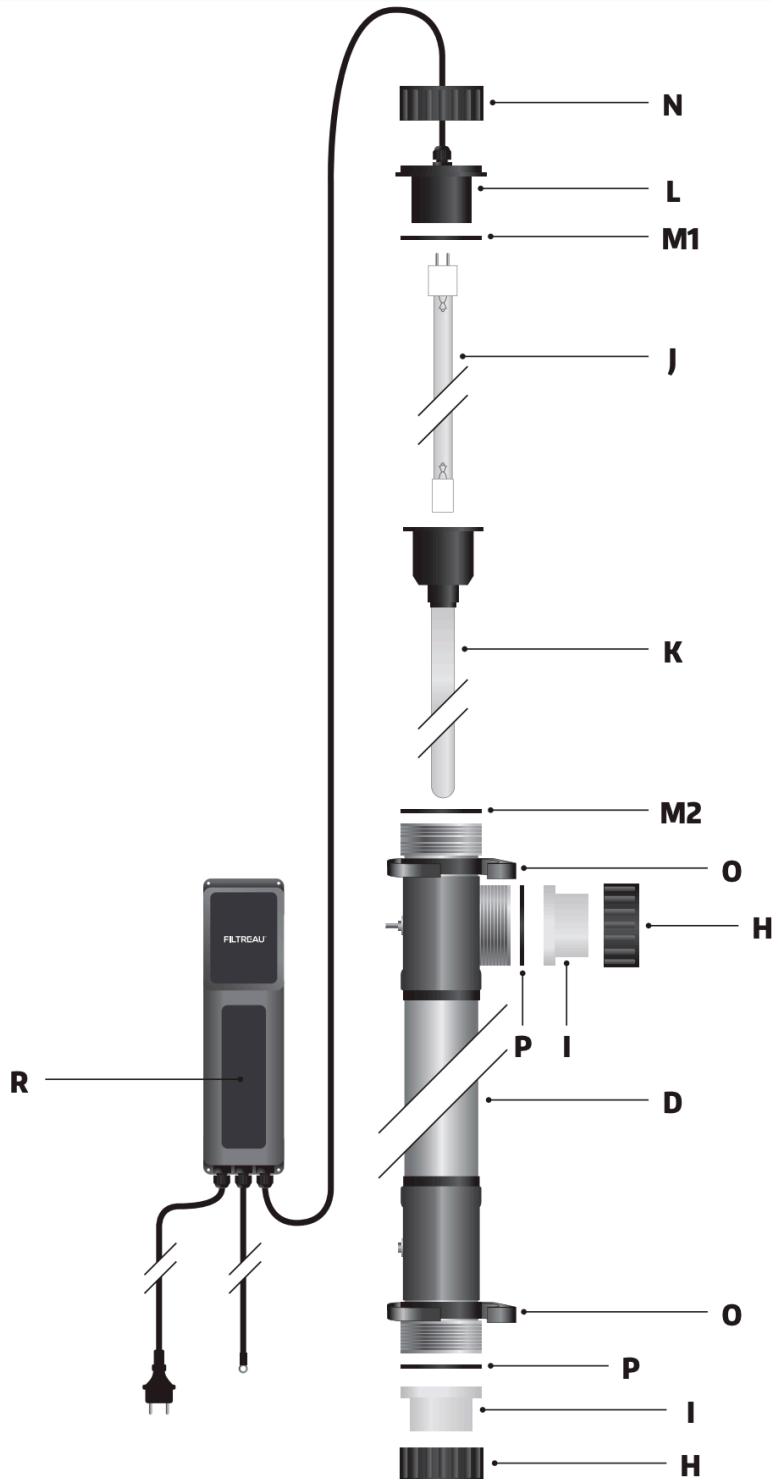

Components

- Lock nut (H)
- Housing (D)
- Connection coupling (I)
- UV-C-lamp (J)
- Quartz glass (K).
- Lamp holder (L)
- O-rings (M1 & M2)
- Nut (N)
- Pipe clamps (O)
- Electronic ballast (R)
- O-rings (P)



[Download online](#)

UVC-LINE

Technical drawing POOL BASIC 16W / 40W / 80W

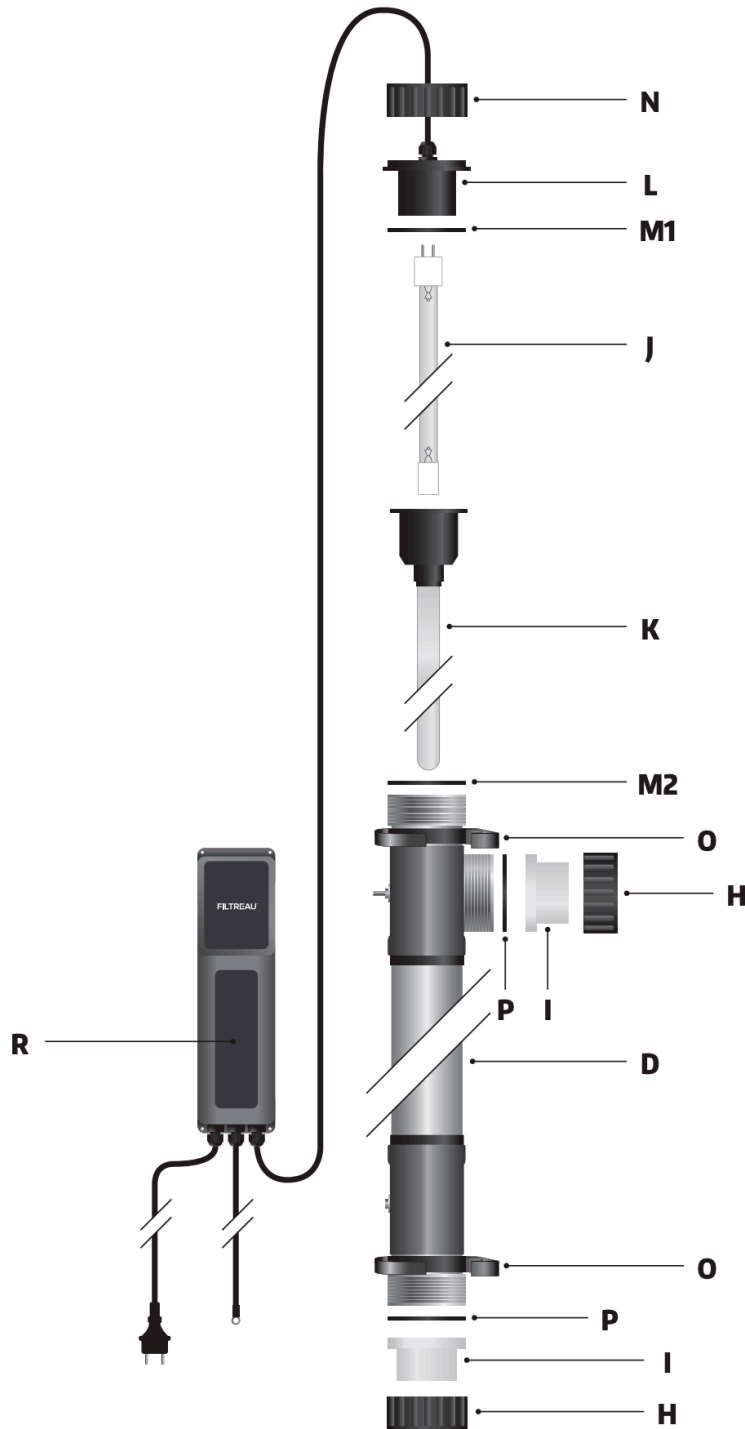

Components

- Lock nut (H)
- Housing (D) A
- Connection coupling (I)
- UV-C-lamp (J)
- Quartz glass (K).
- Lamp holder (L)
- O-rings (M1 & M2)
- Nut (N)
- Pipe clamps (O)
- Electronic ballast (R)
- O-rings (P)



Download online

UVC-LINE

Technical drawing UVC Salt 16W / 40W / 80W

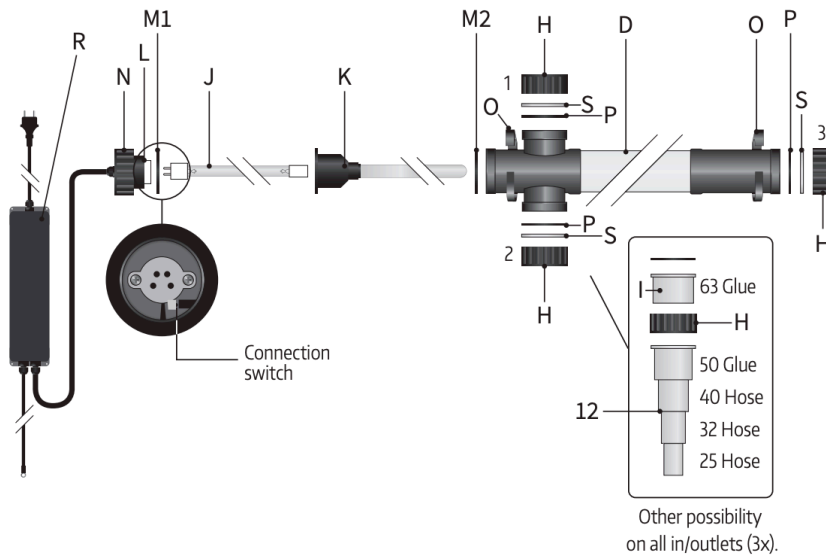

Components

- Lock nut (H)
- Housing (D)
- Connection coupling (I / I2)
- UV-C-lamp (J)
- Quartz glass (K).
- Lamp holder (L)
- O-rings (M1 & M2)
- Nut (N)
- Pipe clamps (O)
- O-rings (P)
- Electronic ballast (R)
- End caps (S)



[Download online](#)

UVC-LINE

Technical drawing UVC Select 40W / 80W / 120W Amalgam

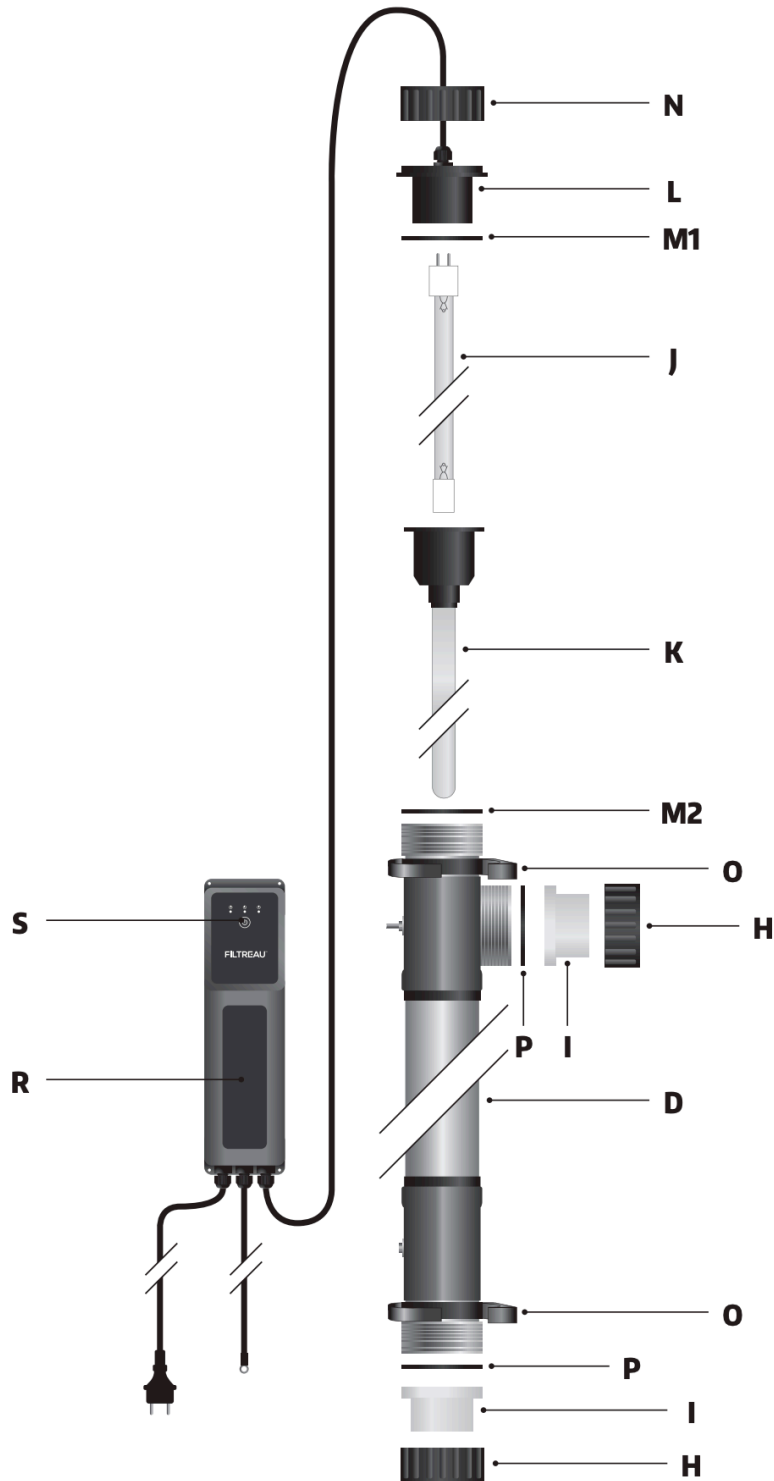

Components

- Lock nut (H)
- Housing (D)
- Connection coupling (I)
- UV-C-lamp (J)
- Quartz glass (K).
- O-rings (M1 & M2)
- Nut (N)
- Pipe clamps (O)
- O-rings (P)
- Electronic ballast (R)



[Download online](#)

UVC-LINE

Technical drawing UVC Slim 40W / 80W

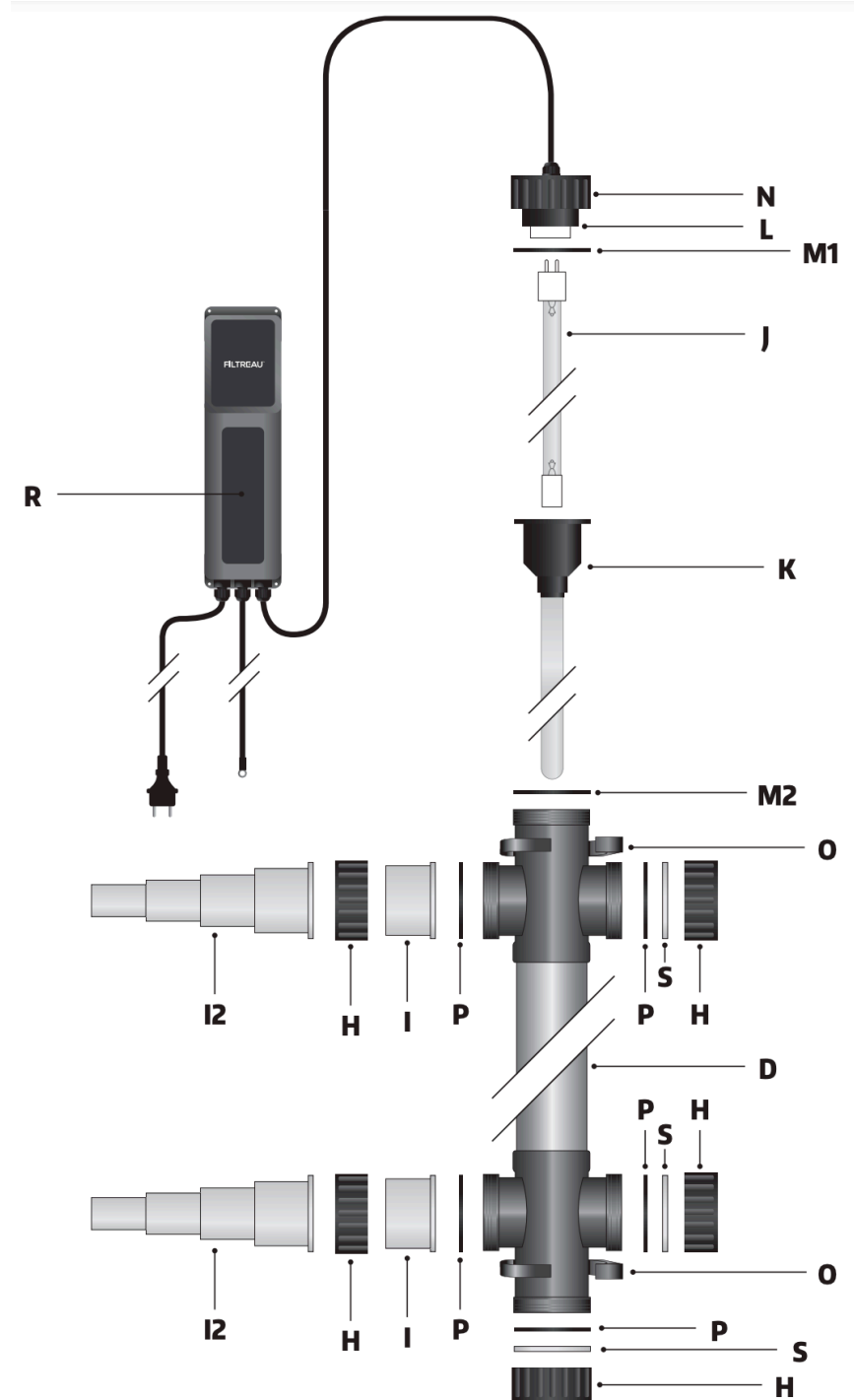

Components

- Lock nut (H)
- Housing (D)
- Connection coupling (I / I2)
- UV-C-lamp (J)
- Quartz glass (K)
- Lamp holder (L)
- O-rings (M1 & M2)
- Nut (N)
- Pipe clamps (O)
- Electronic ballast (R)
- O-rings (P)
- End caps (S)



[Download online](#)

UVC-LINE

Technical drawing UVC Aarding

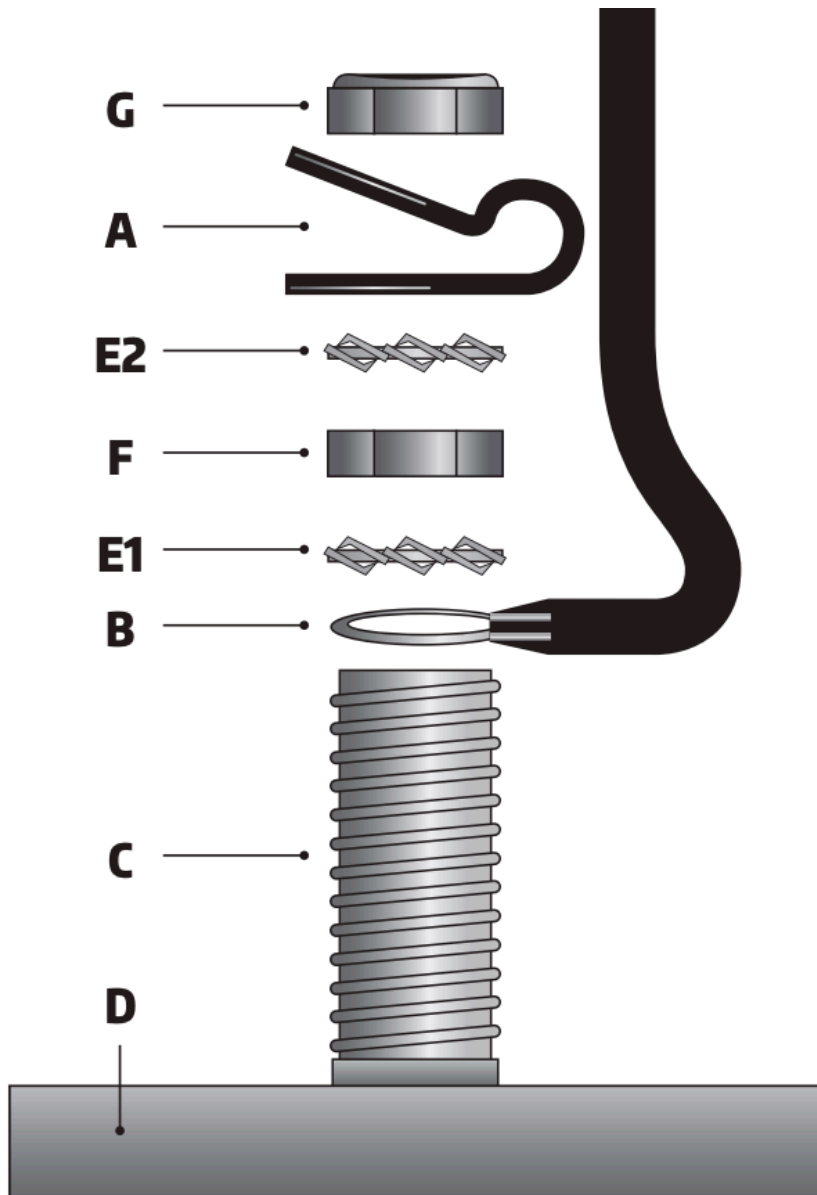

Components

- Strain relief clip (A)
- Grounding cable (B)
- Grounding pin (C)
- Housing (D)
- Toothed lock washer (E1 / E2)
- Hexagonal nut (F)
- Lock nut (G)



[Download online](#)



UV-C lamps

Replacement lamps

UV-C Replacement lamps

What is the lifespan of a UV lamp and when should it be replaced?

A UV lamp has an average effective lifespan of 8,000–12,000 hours. An ozone lamp has an average lifespan of 8,000 hours. After these hours have elapsed, the lamp may still operate, but its disinfection performance decreases relatively quickly. It is therefore essential to replace the lamp in time.

Our advice: Our recommendation is to replace the UV-C lamp once a year, as 12,000 hours is approximately equivalent to one year of operation. It is also advisable to replace the lamp annually around the same period, preferably in spring.

This ensures that pond and swimming pool owners benefit from clean, clear and healthy water throughout the entire summer season. Some Filtreau UV-C products are equipped with a built-in timer to accurately track operating hours. This allows you to see exactly when the lamp needs to be replaced. The display indicates when replacement is required.

Our advice: Always replace the lamp at the same time each year.

Why a UV-C lamp?

Bacteria can become resistant to chemicals, making it necessary to use higher doses or stronger chemicals in the pond or swimming pool. However, this does not eliminate bacterial resistance, meaning the dosage must be continually increased.

This can be easily prevented by treating the bacteria with UV-C light (ultraviolet). UV light has the advantage of remaining effective at all times, without the risk of bacterial resistance.

WARNING:

Do not look directly at UV light, as it is harmful to the eyes.



QUALITY
UV-C LAMPS

FILTREAU™

QUALITY
SUPPLIERS

Art. RLU0001
40W Lamp - Long-pin

SUITABLE FOR:

- Budget UVC (red base)
- Superfish Alutech (red base)
- Superfish Tech (red base)
- Xclear Budget Flex UVC (red base)
- Aquaforfe Budget Flex UVC (red base)
- Xclear Budget Tech UVC (red base)
- Aquaforfe Budget Tech UVC (red base)
- Xclear Budget UltraFlex UVC (red base)
- Aquaforfe Budget UltraFlex UVC (red base)
- Van Gerven Budget Flex UVC (red base)
- Dompel UVC / Immersion UVC (Aquaforfe/Xclear) (red base)
- Pro 3L UVC (red base)

Art. RLU0002
75W Lamp - Short-pin

SUITABLE FOR:

- Budget UVC (red base)
- Superfish Alutech (red base)
- Superfish Tech (red base)
- Xclear Budget Flex UVC (red base)
- Aquaforfe Budget Flex UVC (red base)
- Xclear Budget Tech UVC (red base)
- Aquaforfe Budget Tech UVC (red base)
- Xclear Budget UltraFlex UVC (red base)
- Aquaforfe Budget UltraFlex UVC (red base)
- Van Gerven Budget Flex UVC (red base)
- Dompel UVC / Immersion UVC (Aquaforfe/Xclear) (red base)
- Pro 3L UVC (red base)

Art. RLU0003
40W Lamp - Long-pin

SUITABLE FOR:

- Blue Lagoon UVC Tech 40 Watt
- Superfish Koi Pro 40 Watt
- Jumbo Tech 40 Watt

Art. RLU0004
75W Lamp - Long-pin

SUITABLE FOR:

- Blue Lagoon UVC Tech 75 Watt
- Superfish Koi Pro 75 Watt
- Jumbo Tech 75 Watt

Art. RLU0005
40W Lamp - GPH843T5L

SUITABLE FOR:

- Aquaforfe Power UVC 40 Watt

Art. RLU0006
75W Lamp - GPH843T5L/HO

SUITABLE FOR:

- Aquaforfe Power UVC 75 Watt
- Aquaforfe Power Signal UVC 75 Watt

Art. RLU0007
40W Lamp - GPH843T5L

SUITABLE FOR:

- Filitreau UVC Pond Basic 40 Watt
- Filitreau UVC Pool Basic 40 Watt
- Blue Lagoon UVC Timer 40 Watt
- Jumbo Koi 40 Watt
- Waterland UVC 40 Watt
- VivioClean 40 Watt
- AquaKing RedLabel 40 Watt
- BioPool 40 Watt
- PondTechnics UVC 40 Watt
- Osaga UVC 40 Watt

Art. RLU0008
75W Lamp - GPH843T5L/HO

SUITABLE FOR:

- Filitreau UVC Pond Basic 75 Watt
- Filitreau UVC Pool Basic 75 Watt
- Blue Lagoon UVC Timer 75 Watt
- Jumbo Koi 75 Watt
- Waterland UVC 75 Watt
- VivioClean 75 Watt
- AquaKing RedLabel 75 Watt
- BioPool 75 Watt
- PondTechnics UVC 75 Watt
- Osaga UVC 75 Watt

Art. RLB0001
16W Lamp - TUV 16W 4P SE

SUITABLE FOR:

- Filitreau UVC Pond Basic 16 Watt
- Filitreau UVC Pool Basic 16 Watt
- Filitreau UVC Compact 16 Watt
- PondTechnics UVC 16 Watt

Art. RLB0002
40W Lamp - TUV 36T5 HE 4P SE

SUITABLE FOR:

- Filitreau UVC Pond Basic 40 Watt
- Filitreau UVC Pool Basic 40 Watt
- Blue Lagoon UVC Timer 40 Watt
- Jumbo Koi 40 Watt
- Waterland UVC 40 Watt
- VivioClean 40 Watt
- AquaKing RedLabel 40 Watt
- BioPool 40 Watt
- PondTechnics UVC 40 Watt
- Osaga UVC 40 Watt

Art. RLB0003
75W Lamp - TUV 36T5 HO 4P SE

SUITABLE FOR:

- Filitreau UVC Pond Basic 75 Watt
- Filitreau UVC Pool Basic 75 Watt
- Blue Lagoon UVC Timer 75 Watt
- Jumbo Koi 75 Watt
- Waterland UVC 75 Watt
- VivioClean 75 Watt
- AquaKing RedLabel 75 Watt
- BioPool 75 Watt
- PondTechnics UVC 75 Watt
- Osaga UVC 75 Watt

Art. RLCOM01
16W Lamp - GPH320T5L

SUITABLE FOR:

- Filitreau UVC Pond Basic 16 Watt
- Filitreau UVC Pool Basic 16 Watt
- Filitreau UVC Compact 16 Watt
- PondTechnics UVC 16 Watt

Art. RLCOM02
40W Lamp - GPH600T5L

SUITABLE FOR:

- Filitreau UVC Compact 40 Watt
- Aquaforfe Midi Power UVC 40 Watt

Art. RLCOM03
75W Lamp - GPH600T5L/HO

SUITABLE FOR:

- Filitreau UVC Compact 75 Watt
- Aquaforfe Midi Power UVC 75 Watt

Art. RLM0001
40W Lamp Amalgam - GPHA35T7SL

SUITABLE FOR:

- Filitreau UVC Module 40 Watt Amalgam
- Filitreau UVC INOX Module 40 Watt Amalgam
- Filitreau Trommelfilter
- Filitreau Combi-HKT
- AEM Module 40 Watt Amalgam
- SuperFish Module 40 Watt Amalgam
- AquaKing RedLabel INOX Module 40 Watt Amalgam
- Sansai UVC Module 40 Watt Amalgam

Art. RLM0002
80W Lamp Amalgam - GPHA650T5L

SUITABLE FOR:

- Filitreau UVC Module 80 Watt Amalgam
- Filitreau UVC INOX Module 80 Watt Amalgam
- AEM Module 80 Watt Amalgam
- SuperFish Module 80 Watt Amalgam
- AquaKing RedLabel Module 80 Watt Amalgam
- AquaKing RedLabel INOX Module 80 Watt Amalgam

Art. RLM0001PH
40W Lamp Amalgam - GPHA35T7SL

SUITABLE FOR:

- Xclear Dompel UVC 40 Watt Amalgam
- Aquaforfe Dompel UVC / Immersion UVC 40 Watt Amalgam
- VGE Dompel UVC / Immersion UVC 40 Watt Amalgam

Art. RLM0002PH
80W Lamp Amalgam - GPHA650T5L

SUITABLE FOR:

- Xclear Dompel UVC 80 Watt Amalgam
- Aquaforfe Dompel UVC / Immersion UVC 80 Watt Amalgam
- VGE Dompel UVC / Immersion UVC 80 Watt Amalgam

Art. RLM0002PH2
80W Lamp Short Amalgam - GPHA598T5L

SUITABLE FOR:

- Xclear Dompel UVC / Immersion UVC 80 Watt Amalgam
- Aquaforfe Dompel UVC / Immersion UVC 80 Watt Amalgam
- VGE Dompel UVC / Immersion UVC 80 Watt Amalgam

Art. RLM0020
40W High-output - GPH357T5LCA-HO

SUITABLE FOR:

- Filitreau UVC Module 40 Watt High-Output
- Filitreau UVC INOX Module 40 Watt High-Output
- Filitreau Combi-2
- Filitreau Drumfilter HF30
- Filitreau Combi AFTER
- AquaKing RedLabel Module 40 Watt High-Output
- AquaKing RedLabel INOX Module 40 Watt High-Output
- AEM Module 40 Watt High-Output
- Pond Technics DP Clean 40 Watt High-Output

Art. RLM0021
80W High-output - GPH650T5LCA-HO

SUITABLE FOR:

- Filitreau UVC Module 80 Watt High-Output
- Filitreau UVC INOX Module 80 Watt High-Output
- AquaKing RedLabel Module 80 Watt High-Output
- AquaKing RedLabel INOX Module 80 Watt High-Output
- AEM Module 80 Watt High-Output
- Pond Technics DP Clean 80 Watt High-Output

Art. RLS0001
40W Lamp - GPH843T5LCA

SUITABLE FOR:

- Filitreau UVC Select 40 Watt
- Filitreau UVC Titan 40 Watt
- Puring UVC Bright 40 Watt

Art. RLS0002
80W Lamp - GPH843T5LCA

SUITABLE FOR:

- Filitreau UVC Select 80 Watt
- Filitreau UVC Titan 80 Watt
- Puring UVC Bright 80 Watt

Art. RLS0003
120W Lamp Amalgam - GIA843T5LCA

SUITABLE FOR:

- Filitreau UVC Select 120 Watt Amalgam
- Filitreau UVC Titan 120 Watt Amalgam
- Puring UVC Bright 120 Watt Amalgam

Art. RLSL002
40W Lamp - GPH843T5LCA

SUITABLE FOR:

- Filitreau UVC Slim 40 Watt

Art. RLSL003
80W Lamp - GPH843T5LCA

SUITABLE FOR:

- Filitreau UVC Slim 80 Watt

Art. RLE0001
16W ECO Lamp - GPH450T5L

SUITABLE FOR:

- Filitreau UVC ECO 16 Watt

Art. RLE0002
40W ECO Lamp - GPH850T5L

SUITABLE FOR:

- Filitreau UVC ECO 40 Watt

Art. RLE0003
80W ECO Lamp - GPH850T5L/HO

SUITABLE FOR:

- Filitreau UVC ECO 80 Watt

Wimaca International BV
Ekkersrijt 7418
5692 HK Son
The Netherlands

Telefoon: +31(0)499-462929
E-mail: info@wimaca.nl

www.filtreau.nl



Components

Essential components

Components

Discover the individual components

Sometimes it is not necessary to replace the entire product, but only a single component. For every Filtreau UV-C unit and/or drum filter we supply, individual components are available.

Would you like to learn more about Filtreau components, or are you unsure which part you need? Please feel free to contact our expert team. We are happy to assist you.

Accessoires

Need accessories or replacement components for your UV-C lamp or filtration system? View the components below. Not sure which one you need, or have a question? Please contact our customer service team.

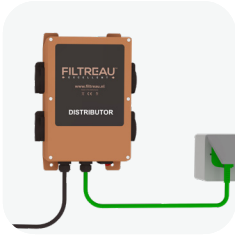

Power Distributor

WMC80WLC-1



Floater

30000045SS



Water level controller

WMC80WLC

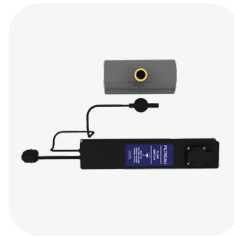

Flow Switch Main

FS0001



Product range list

[Barcode overview](#)





Product list

Product	Item no.	EAN / Barcode
BIO DRUM 25 M GRAVITY	WMC01DRG	7 428477 428876 >
BIO DRUM 25 M PUMP	WMC01DRP	7 428475 583614 >
BIO DRUM 35 L GRAVITY	WMC02DRG	7 428473 101698 >
BIO DRUM 35 L PUMP	WMC02DRP	7 428473 659175 >
BIO DRUM 60 XL GRAVITY	WMC03DRG	7 428475 071821 >
BIO DRUM 60 XL PUMP	WMC03DRP	7 428472 760674 >
BIO DRUM 100 XXLGRAVITY	WMC04DRG	7 428471 915556 >
BIO DRUM 100 XXL PUMP	WMC04DRP	7 428474 895886 >
COMBI DRUM 25/30 GRAVITY	WMC10PPG	7 428470 601559 >
COMBI DRUM 25/30 PUMP	WMC10PPP	7 428470 644242 >
TRICKLE FOR COMBI DRUM 20/25	WMC10PPT	7 428477 864346 >
COMBI DRUM 20/25 LOW GRAVITY	WMC11PPG	7 428479 737969 >
COMBI DRUM 20/25 LOW PUMP	WMC11PPP	7 428473 194003 >
TRICKLE FOR COMBI DRUM 20/25 LOW	WMC11PPT	7 428477 722981 >
COMBI DRUM 25/30 LOW GRAVITY	WMC20CDG	7 428476 281540 >
COMBI DRUM 25/30 LOW PUMP	WMC20CDP	7 428472 384412 >











Product	Item no.	EAN / Barcode
TRICKLE FOR COMBI DRUM 25/30 LOW	WMC20CDT	 7 428479 263796 >
COMBI DRUM 30/50 GRAVITY	WMC21CDG	 7 428474 335511 >
COMBI DRUM 30/50 PUMP	WMC21CDP	 7 428471 333558 >
TRICKLE FOR COMBI DRUM 30/50	WMC21CDT	 7 428475 718061 >
COMBI DRUM 50/70 GRAVITY	WMC22CDG	 7 428473 913536 >
COMBI DRUM 50/70 PUMP	WMC22CDP	 7 428479 941007 >
TRICKLE FOR COMBI DRUM 50/70	WMC22CDT	 7 428470 746588 >
COMBI DRUM 60/80 XL GRAVITY	WMC23CDG	 7 428472 508054 >
COMBI DRUM 60/80 XL PUMP	WMC23CDP	 7 428473 013533 >
TRICKLE FOR COMBI DRUM 60/80 XL	WMC23CDT	 7 428479 914414 >
COMBI DRUM 80/100 XXL GRAVITY	WMC24CDG	 7 428475 990344 >
COMBI DRUM 80/100 XXL PUMP	WMC24CDP	 7 428476 891862 >
TRICKLE FOR COMBI DRUM 80/100 XXL	WMC24CDT	 7 428472 789156 >
COMBI DRUM 25/30 LOW In Line GRAVITY	WMC30ILG	 7 428479 466647 >
COMBI DRUM 25/30 LOW In Line PUMP	WMC30ILP	 7 428478 389909 >
TRICKLE FOR COMBI DRUM 25/30 LOW	WMC30ILT	 7 484765 589360 >

Product list

Product	Item no.	EAN / Barcode
COMBI DRUM 30/40 LOW GRAVITY	WMC31ILG	7 428474 672449 >
COMBI DRUM 30/40 LOW PUMP	WMC31ILP	7 428475 982639 >
TRICKLE FOR COMBI DRUM 30/40 LOW	WMC31ILT	7 428471 240085 >
COMBI DRUM 30/45L GRAVITY	WMC32ILG	7 428477 673016 >
COMBI DRUM 30/45L PUMP	WMC32ILP	7 428479 767539 >
TRICKLE FOR COMBI DRUM 30/45L	WMC32ILT	7 428478 267757 >
COMBI DRUM 50/65XL GRAVITY	WMC33ILG	7 428470 670005 >
COMBI DRUM 50/65XL PUMP	WMC33ILP	7 428471 721904 >
TRICKLE FOR COMBI DRUM 50/65XL	WMC33ILT	7 428479 593251 >
COMBI DRUM 80/100XXL IN LINE GRAVITY	WMC34ILG	7 428470 206051 >
COMBI DRUM 80/100XXL IN LINE PUMP	WMC34ILP	7 428470 498289 >
TRICKLE FOR COMBI DRUM 80/100XXL	WMC34ILT	7 428478 479549 >
COMBI DRUM 30/50 ROTATE GRAVITY	WMC40ROG	7 428479 058347 >
COMBI DRUM 30/50 ROTATE PUMP	WMC40ROP	7 428475 235056 >
TRICKLE FOR COMBI DRUM 30/50 ROTATE	WMC40ROT	7 428478 116420 >
COMBI DRUM 50/70 ROTATE GRAVITY	WMC41ROG	7 428474 947547 >

Product	Item no.	EAN / Barcode
COMBI DRUM 50/70 ROTATE PUMP	WMC41ROP	 7 428477 666773 >
TRICKLE FOR COMBI DRUM 50/70 ROTATE	WMC41ROT	 7 428474 228752 >

FILTREAU™ - BASIC LIJN

Product	Item no.	EAN / Barcode
Trickle filter 110 mm outlet	TRI0002	 7 428476 209742 >
Trickle filter Waterfall	TRI0001	 7 428477 788086 >
50XL drum Pump-fed incl. 2x UV-C SPG XL	TR00014	 7 428476 565923 >
50XL drum Gravity incl. 2x UV-C SPG XL	TR00013	 7 428475 249091 >
Rotate BioFilter Pump-fed incl. 2x UV-C 2x SPG XL	RO00001PFIN	 7 428470 520720 >
Rotate BioFilter Gravity incl. 2x UV-C 2x SPG XL	RO00001IN	 7 428470 764940 >
Combi 50XL Pump-Fed / incl. rinsepump incl. 2x UV-C	COM0050PFIN	 7 428470 535281 >
Combi 50XL Gravity/ incl. rinsepump incl. 2x UV-C	COM0050IN	 7 428470 855716 >
Filtreau combi-2 pumped (jap. mats) incl. UVC /incl. rinsepump	COM0021PFIN	 7 428477 192555 >
Filtreau combi-2 gravity (jap. mats) incl. UVC /incl. rinsepump	COM0021IN	 7 428470 148931 >

Product list

Product	Item no.	EAN / Barcode
Filtreau combi-2 SPG XL gravity (moving-bed) incl. UVC /incl. rinsepump	COMSP20IN	7 428474 157731 >
Filtreau combi-2 SPG XL pumped (moving-bed) incl. UVC /incl. rinsepump	COMSP20PFIN	7 428474 983156 >
Filtreau combi-2 pumped (moving-bed) incl. UVC /incl. rinsepump	COM0020PFIN	7 428476 664060 >
Filtreau combi-2 gravity (moving-bed) incl. UVC /incl. rinsepump	COM0020IN	7 428474 227397 >
Filtreau combi-2 SPG XL gravity (Jap. mats) incl. UVC (pumped)	COMSP21PF	7 428472 714349 >
Filtreau combi-2 SPG XL gravity (Jap. mats) incl. UVC	COMSP21	7 428479 099968 >
Filtreau combi-2 gravity (Jap. mats) incl. UVC (pumped)	COM0021PF	7 428479 683051 >
Filtreau combi-2 gravity (Jap. mats) incl. UVC	COM0021	7 428478 773388 >
Filtreau combi-2 SPG XL gravity (moving-bed) incl. UVC (pumped)	COMSP20PF	7 428472 277356 >
Filtreau combi-2 SPG XL gravity (moving-bed) incl. UVC	COMSP20	7 428475 035847 >
Filtreau combi-2 gravity (moving-bed) incl. UVC (pumped)	COM0020PF	7 428475 049547 >
Filtreau combi-2 gravity (moving-bed) incl. UVC	COM0020	7 428478 894359 >
Filtreau combi-AFTER incl. UVC (Pumped) incl. rinsepump	COM0003PFIN	7 428471 982909 >
Filtreau combi-AFTER incl. UVC (Gravity) incl. rinsepump	COM0003IN	7 428475 509348 >
Filtreau combi-AFTER incl. UVC (Pumped)	COM0003PF	7 428475 715251 >
Filtreau combi-AFTER incl. UVC (Gravity)	COM0003	7 428477 678233 >

Product	Item no.	EAN / Barcode
Filtreau combi-NEXT incl. UVC (Pump-Fed) SPG XL motor incl. rinsepump	COMSP02PFIN	 7 428474 679332 >
Filtreau combi-NEXT incl. UVC (Gravity) SPG XL motor incl. rinsepump	COMSP02IN	 7 428475 864072 >
Filtreau combi-NEXT incl. UVC (Pump-Fed) SPG XL motor	COMSP02PF	 7 428476 811006 >
Filtreau combi-NEXT incl. UVC (Gravity) SPG XL motor	COMSP02	 7 428472 833200 >
Filtreau combi-NEXT incl. UVC (Pump-fed) PP incl. rinsepump	COM0002PFIN	 7 428475 477784 >
Filtreau combi-NEXT incl. UVC (Gravity) PP incl. rinsepump	COM0002IN	 7 428478 156648 >
Filtreau combi-NEXT incl. UVC (Pump-fed) PP	COM0002PF	 7 428478 238511 >
Filtreau combi-NEXT incl. UVC (Gravity) PP	COM0002	 7 428478 918925 >
Filtreau PF20 combi-filter (Pump-fed) PP	COM0001	 7 428473 762691 >
Filtreau moving-bed filter 190L PE	BB00001	 7 428470 050258 >
Filtreau Drum-Filter HF30 (Pump-fed) SPG XL motor	TRSPG05	 7 428476 525682 >
Filtreau Drum-Filter HF30 (Gravity) SPG XL motor	TRSPG04	 7 428475 615933 >
Filtreau Drum-Filter HF30 (Pump-fed) PP	TR00005	 7 428473 287460 >
Filtreau Drum-Filter HF30 (Gravity) PP	TR00004	 7 428478 365965 >
Filtreau Drum-Filter incl. UVC (Pump-fed)	TR00003	 7 428478 704054 >
Filtreau Drum-Filter incl. UVC (Gravity)	TR00001	 7 428470 606059 >

